

FOREWORD

This wiring diagram manual has been prepared to provide information on the electrical system of the 2007 SCION tC.

Applicable models: ANT10 Series

Refer to the following manuals for additional service specifications and repair procedures for these models:

| Manual Name | Pub. No. |
|----------------------------------|----------|
| ● 2007 SCION tC Repair Manual | RM0300U |
| ● 2007 SCION tC New Car Features | NM0300U |

All information in this manual is based on the latest product information at the time of publication. However, specifications and procedures are subject to change without notice.

TOYOTA MOTOR CORPORATION

NOTICE

Always follow the directions given in the above repair manuals when handling supplemental restraint system components (such as removal, installation, inspection, etc.) in order to prevent accidents and supplemental restraint system malfunction.

©2006 TOYOTA MOTOR CORPORATION

All rights reserved. This book may not be reproduced or copied, in whole or in part, without the written permission of Toyota Motor Corporation.

First Printing : May 29, 2006 01-060529-00

2007 tC

ELECTRICAL WIRING DIAGRAM

| | Section Code | Page |
|---|--------------|------|
| INTRODUCTION | A | 2 |
| HOW TO USE THIS MANUAL | B | 3 |
| TROUBLESHOOTING | C | 12 |
| ABBREVIATIONS | D | 17 |
| GLOSSARY OF TERMS AND SYMBOLS | E | 18 |
| RELAY LOCATIONS | F | 20 |
| ELECTRICAL WIRING ROUTING | G | 34 |
| SYSTEM CIRCUITS | H | 45 |
| GROUND POINT | I | 184 |
| POWER SOURCE (Current Flow Chart) | J | 188 |
| CONNECTOR LIST | K | 194 |
| PART NUMBER OF CONNECTORS | L | 206 |
| OVERALL ELECTRICAL WIRING DIAGRAM . | M | 210 |

A INTRODUCTION

This manual consists of the following 13 sections:

| No. | Section | Description |
|-----|-----------------------------------|---|
| A | INDEX | Index of the contents of this manual. |
| | INTRODUCTION | Brief explanation of each section. |
| B | HOW TO USE THIS MANUAL | Instructions on how to use this manual. |
| C | TROUBLE-SHOOTING | Describes the basic inspection procedures for electrical circuits. |
| D | ABBREVIATIONS | Defines the abbreviations used in this manual. |
| E | GLOSSARY OF TERMS AND SYMBOLS | Defines the symbols and functions of major parts. |
| F | RELAY LOCATIONS | Shows position of the Electronic Control Unit, Relays, Relay Block, etc. This section is closely related to the system circuit. |
| G | ELECTRICAL WIRING ROUTING | Describes position of Parts Connectors, Splice points, Ground points, etc. This section is closely related to the system circuit. |
| H | INDEX | Index of the system circuits. |
| | SYSTEM CIRCUITS | Electrical circuits of each system are shown from the power supply through ground points. Wiring connections and their positions are shown and classified by code according to the connection method. (Refer to the section, "How to use this manual"). The "System Outline" and "Service Hints" useful for troubleshooting are also contained in this section. |
| I | GROUND POINT | Shows ground positions of all parts described in this manual. |
| J | POWER SOURCE (Current Flow Chart) | Describes power distribution from the power supply to various electrical loads. |
| K | CONNECTOR LIST | Describes the form of the connectors for the parts appeared in this book. This section is closely related to the system circuit. |
| L | PART NUMBER OF CONNECTORS | Indicates the part number of the connectors used in this manual. |
| M | OVERALL ELECTRICAL WIRING DIAGRAM | Provides circuit diagrams showing the circuit connections. |

This manual provides information on the electrical circuits installed on vehicles by dividing them into a circuit for each system.

The actual wiring of each system circuit is shown from the point where the power source is received from the battery as far as each ground point. (All circuit diagrams are shown with the switches in the OFF position.)

When troubleshooting any problem, first understand the operation of the circuit where the problem was detected (see System Circuit section), the power source supplying power to that circuit (see Power Source section), and the ground points (see Ground Point section). See the System Outline to understand the circuit operation.

When the circuit operation is understood, begin troubleshooting of the problem circuit to isolate the cause. Use Relay Location and Electrical Wiring Routing sections to find each part, junction block and wiring harness connectors, wiring harness and wiring harness connectors and ground points of each system circuit. Internal wiring for each junction block is also provided for better understanding of connection within a junction block.

Wiring related to each system is indicated in each system circuit by arrows (from__, to__). When overall connections are required, see the Overall Electrical Wiring Diagram at the end of this manual.

[A] : System Title

[B] : Indicates a Relay Block. No shading is used and only the Relay Block No. is shown to distinguish it from the J/B

Example: ① Indicates Relay Block No.1

[C] : () is used to indicate different wiring and connector, etc. when the vehicle model, engine type, or specification is different.

[D] : Indicates related system.

[E] : Indicates the wiring harness and wiring harness connector. The wiring harness with male terminal is shown with arrows (↘).

Outside numerals are pin numbers.

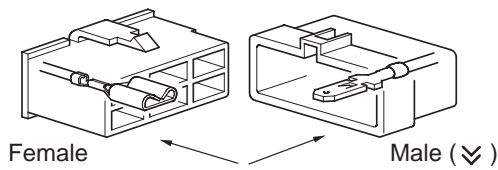

The first letter of the code for each wiring harness and wiring harness connector(s) indicates the component's location, e.g, "E" for the Engine Compartment, "I" for the Instrument Panel and Surrounding area, and "B" for the Body and Surrounding area.

When more than one code has the first and second letters in common, followed by numbers (e.g, IH1, IH2), this indicates the same type of wiring harness and wiring harness connector.

[F] : Represents a part (all parts are shown in sky blue). The code is the same as the code used in parts position.

[G] : Junction Block (The number in the circle is the J/B No. and the connector code is shown beside it). Junction Blocks are shaded to clearly separate them from other parts.

Example:

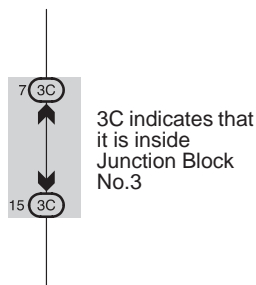

[H] : Indicates the wiring color.

Wire colors are indicated by an alphabetical code.

- B = Black W = White BR = Brown
- L = Blue V = Violet SB = Sky Blue
- R = Red G = Green LG = Light Green
- P = Pink Y = Yellow GR = Gray
- O = Orange

The first letter indicates the basic wire color and the second letter indicates the color of the stripe.

Example: L - Y

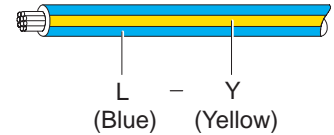

[I] : Indicates a wiring Splice Point

Example:

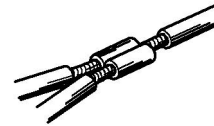

[J] : Indicates a shielded cable.



[K] : Indicates the pin number of the connector. The numbering system is different for female and male connectors.

Example: Numbered in order from upper left to lower right

Numbered in order from upper right to lower left

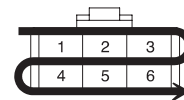

Female



Male

[L] : Indicates a ground point.

The first letter of the code for each ground point(s) indicates the component's location, e.g, "E" for the Engine Compartment, "I" for the Instrument Panel and Surrounding area, and "B" for the Body and Surrounding area.

[M] : Page No.

[N] : Indicates the ignition key position(s) when the power is supplied to the fuse(s).

B HOW TO USE THIS MANUAL

[O] System Outline

Current is applied at all times through the STOP fuse to TERMINAL 2 of the stop light SW.
When the ignition SW is turned on, current flows from the GAUGE fuse to TERMINAL 8 of the light failure sensor, and also flows through the rear lights warning light to TERMINAL 4 of the light failure sensor.

Stop Light Disconnection Warning

When the ignition SW is turned on and the brake pedal is pressed (Stop light SW on), if the stop light circuit is open, the current flowing from TERMINAL 7 of the light failure sensor to TERMINALS 1, 2 changes, so the light failure sensor detects the disconnection and the warning circuit of the light failure sensor is activated.

As a result, the current flows from TERMINAL 4 of the light failure sensor to TERMINAL 11 to GROUND and turns the rear lights warning light on. By pressing the brake pedal, the current flowing to TERMINAL 8 of the light failure sensor keeps the warning circuit on and holds the warning light on until the ignition SW is turned off.

[P] ○ : Parts Location

| Code | See Page | Code | See Page | Code | See Page |
|------|----------|------|----------|------|----------|
| C7 | 34 | L4 | 36 | R7 | 37 |
| H17 | 36 | R6 | 37 | S6 | 35 |

[Q] ○ : Relay Blocks

| Code | See Page | Relay Blocks (Relay Block Location) |
|------|----------|--------------------------------------|
| 1 | 18 | R/B No.1 (Instrument Panel Brace LH) |

[R] ○ : Junction Block and Wire Harness Connector

| Code | See Page | Junction Block and Wire Harness (Connector Location) |
|------|----------|---|
| 3C | 22 | Instrument Panel Wire and J/B No.3 (Instrument Panel Brace LH) |
| IB | 20 | Instrument Panel Wire and Instrument Panel J/B (Lower Finish Panel) |

[S] □ : Connector Joining Wire Harness and Wire Harness

| Code | See Page | Joining Wire Harness and Wire Harness (Connector Location) |
|------|----------|--|
| IE1 | 42 | Floor Wire and Instrument Panel Wire (Left Kick Panel) |
| BV1 | 50 | Luggage Room Wire and Floor Wire (Luggage Room Left) |

[T] ▽ : Ground Points

| Code | See Page | Ground Points Location |
|------|----------|------------------------------|
| BL | 50 | Under the Left Center Pillar |
| BO | 50 | Back Panel Center |

[O] : Explains the system outline.

[P] : Indicates the reference page showing the position on the vehicle of the parts in the system circuit.

Example : Part "L4" (Light Failure Sensor) is on page 36 of the manual.

* The letter in the code is from the first letter of the part, and the number indicates its order in parts starting with that letter.

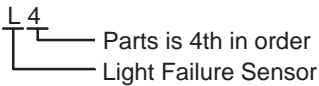
Example : L 4

[Q] : Indicates the reference page showing the position on the vehicle of Relay Block Connectors in the system circuit.

Example : Connector "1" is described on page 18 of this manual and is installed on the left side of the instrument panel.

[R] : Indicates the reference page showing the position on the vehicle of J/B and Wire Harness in the system circuit.

Example : Connector "3C" connects the Instrument Panel Wire and J/B No.3. It is described on page 22 of this manual, and is installed on the instrument panel left side.

[S] : Indicates the reference page describing the wiring harness and wiring harness connector (the female wiring harness is shown first, followed by the male wiring harness).

Example : Connector "IE1" connects the floor wire (female) and Instrument panel wire (male). It is described on page 42 of this manual, and is installed on the left side kick panel.

[T] : Indicates the reference page showing the position of the ground points on the vehicle.

Example : Ground point "BO" is described on page 50 of this manual and is installed on the back panel center.

B HOW TO USE THIS MANUAL

The ground points circuit diagram shows the connections from all major parts to the respective ground points. When troubleshooting a faulty ground point, checking the system circuits which use a common ground may help you identify the problem ground quickly. The relationship between ground points (∇_{EA} , ∇_{IB} and ∇_{IC} shown below) can also be checked this way.

I GROUND POINT

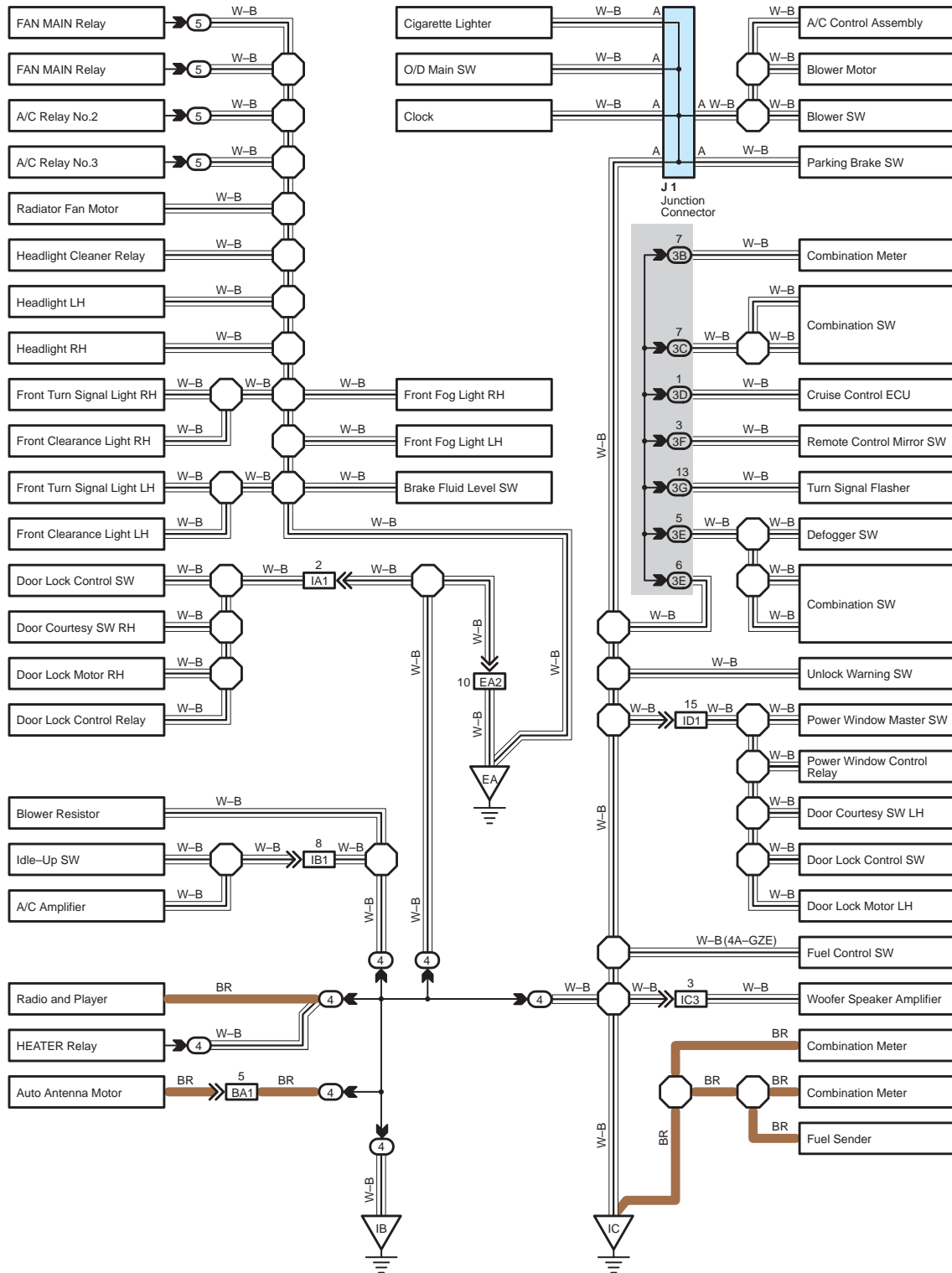

* The system shown here is an EXAMPLE ONLY. It is different to the actual circuit shown in the SYSTEM CIRCUITS SECTION.

The "Current Flow Chart" section, describes which parts each power source (fuses, fusible links, and circuit breakers) transmits current to. In the Power Source circuit diagram, the conditions when battery power is supplied to each system are explained. Since all System Circuit diagrams start from the power source, the power source system must be fully understood.

J POWER SOURCE (Current Flow Chart)

The chart below shows the route by which current flows from the battery to each electrical source (Fusible Link, Circuit Breaker, Fuses, etc.) and other parts

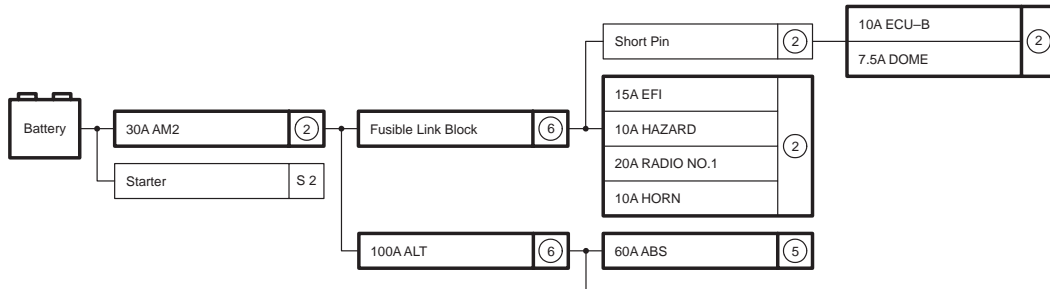

Engine Room R/B (See Page 20)

| Fuse | System | Page |
|-------------|--|------|
| 20A STOP | ABS | 194 |
| | ABS and Traction Control | 187 |
| | Cruise Control | 180 |
| | Electronically Controlled Transmission | 166 |
| | Multiplex Communication System | 210 |
| 10A DOME | Cigarette Lighter | 214 |
| | Combination Meter | 230 |
| | Headlight | 112 |
| | Interior Light | 122 |
| | Key Reminder and Seat Belt Warning | |
| | Light Auto Turn Off System | |

Power Source

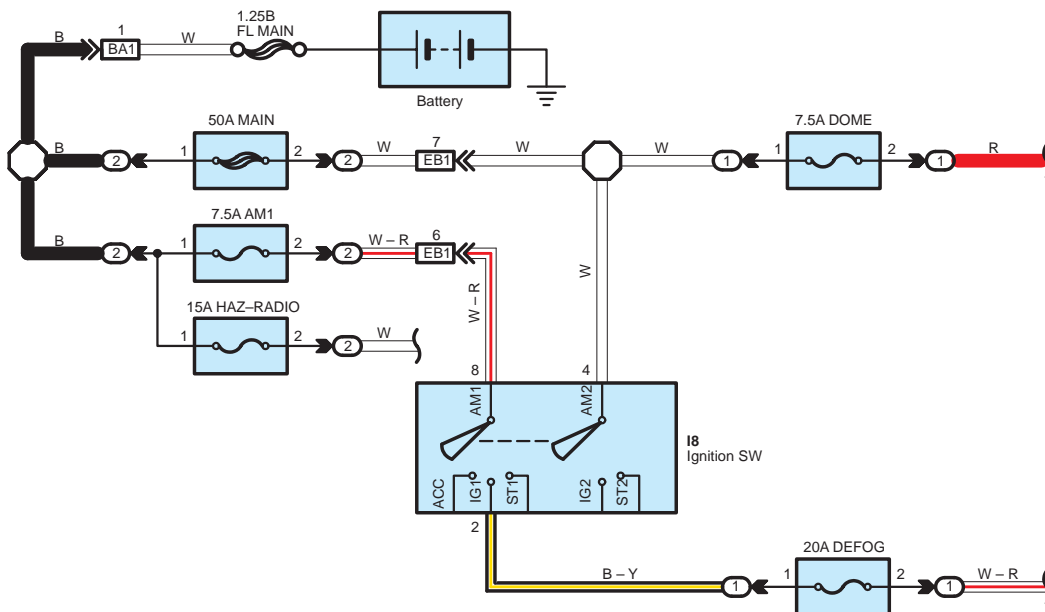

* The system shown here is an EXAMPLE ONLY. It is different to the actual circuit shown in the SYSTEM CIRCUITS SECTION.

B HOW TO USE THIS MANUAL

K CONNECTOR LIST

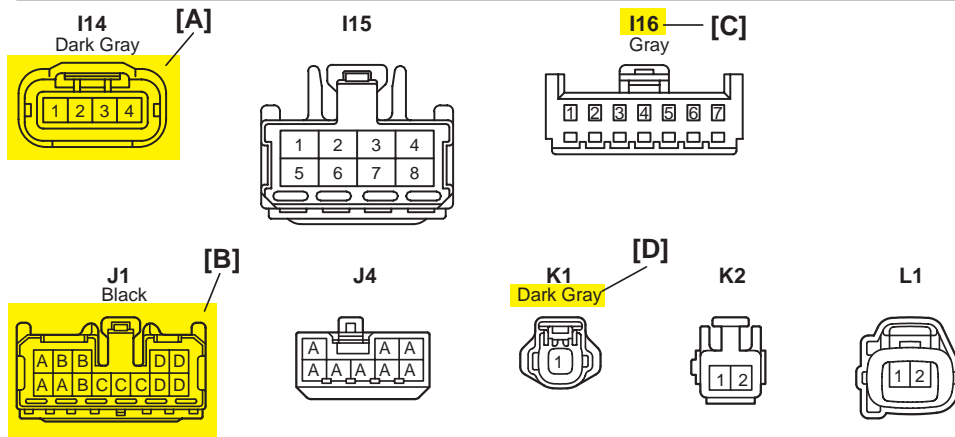

K CONNECTOR LIST

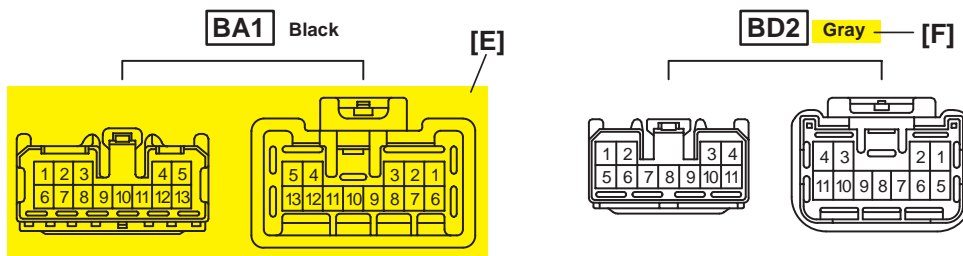

[A] : Indicates connector to be connected to a part. (The numeral indicates the pin No.)

[B] : Junction Connector
Indicates a connector which is connected to a short terminal.

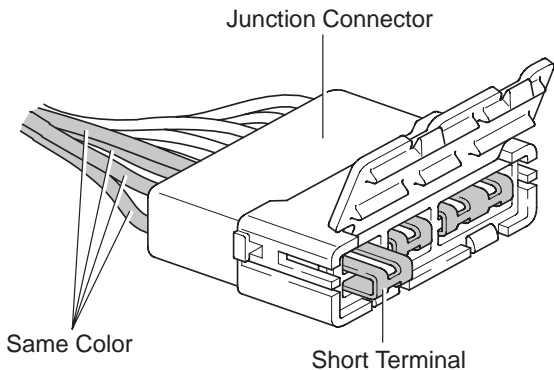

Junction connector in this manual include a short terminal which is connected to a number of wire harnesses. Always perform inspection with the short terminal installed. (When installing the wire harnesses, the harnesses can be connected to any position within the short terminal grouping. Accordingly, in other vehicles, the same position in the short terminal may be connected to a wire harness from a different part.)
Wire harness sharing the same short terminal grouping have the same color.

[C] : Parts Code
The first letter of the code is taken from the first letter of part, and the numbers indicates its order in parts which start with the same letter.

[D] : Connector Color
Connectors not indicated are milky white in color.

[E] : Indicates the connector shapes which are used to join wire harnesses.
On Left : Female connector shapes
On Right : Male connector shapes
Numbers indicate pin numbers.

[F] : Indicates connector colors. (Connectors with not indicated colors are white)

L PART NUMBER OF CONNECTORS

| Code | Part Name | Part Number | Code | Part Name | Part Number |
|------|----------------------------|-------------|------|-------------------------------------|-------------|
| A 1 | A/C Ambient Temp. Sensor | 90980-11070 | D 4 | Diode (Courtesy) | 90980-11608 |
| A 2 | A/C Condenser Fan Motor | 90980-11237 | D 5 | Diode (Interior Light) | 90980-10962 |
| A 3 | A/C Condenser Fan Relay | 90980-10940 | D 6 | Diode (Moon Roof) | 90980-11608 |
| A 4 | A/C Condenser Fan Resistor | 90980-10928 | D 7 | Door Lock Control Relay | 90980-10848 |
| A 5 | A/C Magnetic Clutch | 90980-11271 | D 8 | Door Lock Control SW LH | 90980-11148 |
| A 6 | A/T Oil Temp. Sensor | 90980-11413 | D 9 | Door Lock Control SW RH | |
| [A] | ABS Actuator [B] | 909-151 [C] | D10 | Door Courtesy SW LH | 90980-11097 |
| A 8 | ABS Actuator | 90980-11009 | D11 | Door Courtesy SW RH | |
| A 9 | ABS Speed Sensor Front LH | 90980-10941 | D12 | Door Courtesy SW Front LH | 90980-11156 |
| A10 | ABS Speed Sensor Front RH | 90980-11002 | D13 | Door Courtesy SW Front RH | |
| A11 | Airbag Sensor Front LH | 90980-11856 | D14 | Door Courtesy SW Rear LH | |
| A12 | Airbag Sensor Front RH | | D15 | Door Courtesy SW Rear RH | |
| A13 | Airbag Sensor Front LH | 90980-11194 | D16 | Door Courtesy Lock and Unlock SW LH | 90980-11170 |
| | | 90980-11194 | | | |

[A] : Part Code

[B] : Part Name

[C] : Part Number
Toyota Part Number are indicated.

Not all of the above part numbers of the connector are established for the supply.

C TROUBLESHOOTING

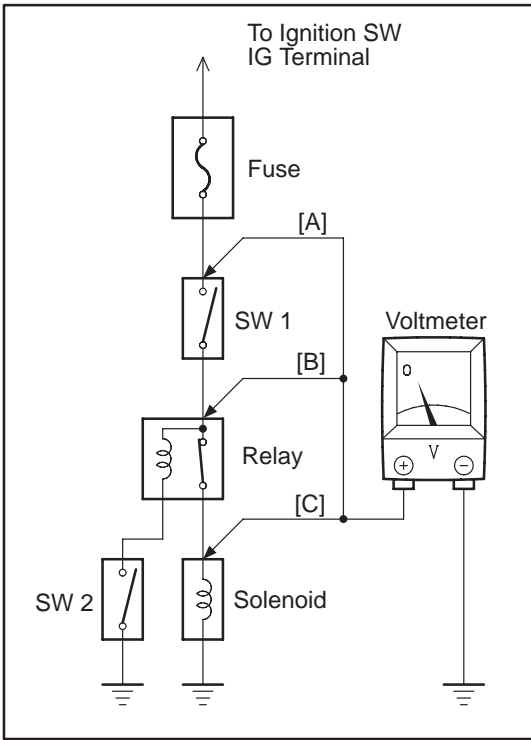

VOLTAGE CHECK

- (a) Establish conditions in which voltage is present at the check point.

Example:

- [A] – Ignition SW on
- [B] – Ignition SW and SW 1 on
- [C] – Ignition SW, SW 1 and Relay on (SW 2 off)

- (b) Using a voltmeter, connect the negative lead to a good ground point or negative battery terminal, and the positive lead to the connector or component terminal. This check can be done with a test light instead of a voltmeter.

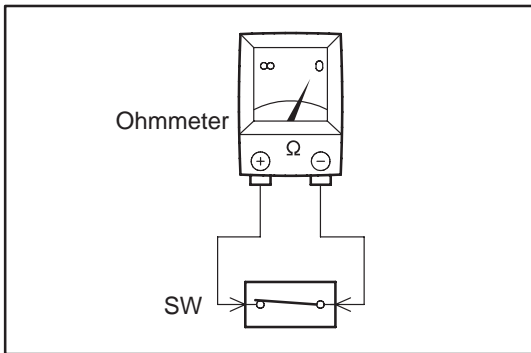

CONTINUITY AND RESISTANCE CHECK

- (a) Disconnect the battery terminal or wire so there is no voltage between the check points.
- (b) Contact the two leads of an ohmmeter to each of the check points.

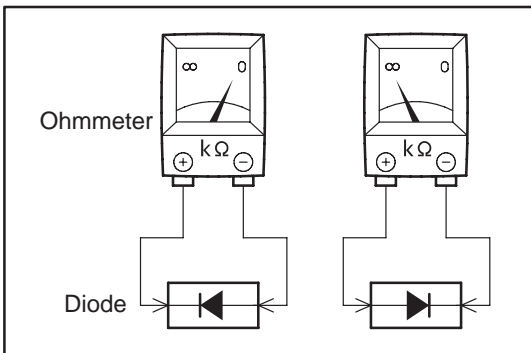

If the circuit has diodes, reverse the two leads and check again.

When contacting the negative lead to the diode positive side and the positive lead to the negative side, there should be continuity.

When contacting the two leads in reverse, there should be no continuity.

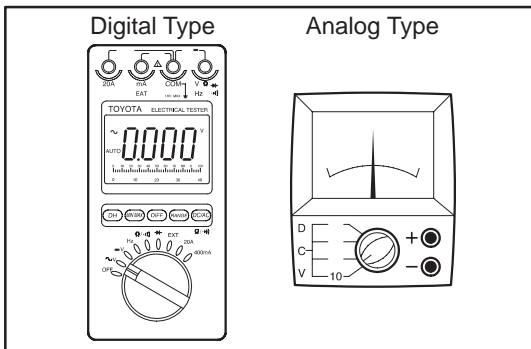

- (c) Use a volt/ohmmeter with high impedance (10 kΩ/V minimum) for troubleshooting of the electrical circuit.

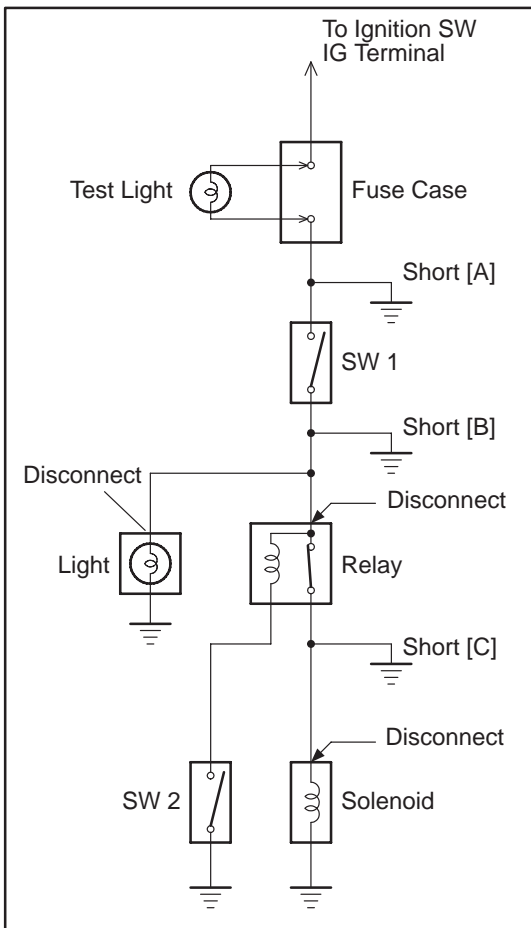

FINDING A SHORT CIRCUIT

- Remove the blown fuse and disconnect all loads of the fuse.
- Connect a test light in place of the fuse.
- Establish conditions in which the test light comes on.

Example:

- [A] – Ignition SW on
- [B] – Ignition SW and SW 1 on
- [C] – Ignition SW, SW 1 and Relay on (Connect the Relay) and SW 2 off (or Disconnect SW 2)

- Disconnect and reconnect the connectors while watching the test light.
The short lies between the connector where the test light stays lit and the connector where the light goes out.
- Find the exact location of the short by lightly shaking the problem wire along the body.

CAUTION:

- Do not open the cover or the case of the ECU unless absolutely necessary. (If the IC terminals are touched, the IC may be destroyed by static electricity.)
- When replacing the internal mechanism (ECU part) of the digital meter, be careful that no part of your body or clothing comes in contact with the terminals of leads from the IC, etc. of the replacement part (spare part).

DISCONNECTION OF MALE AND FEMALE CONNECTORS

To pull apart the connectors, pull on the connector itself, not the wire harness.

HINT: Check to see what kind of connector you are disconnecting before pulling apart.

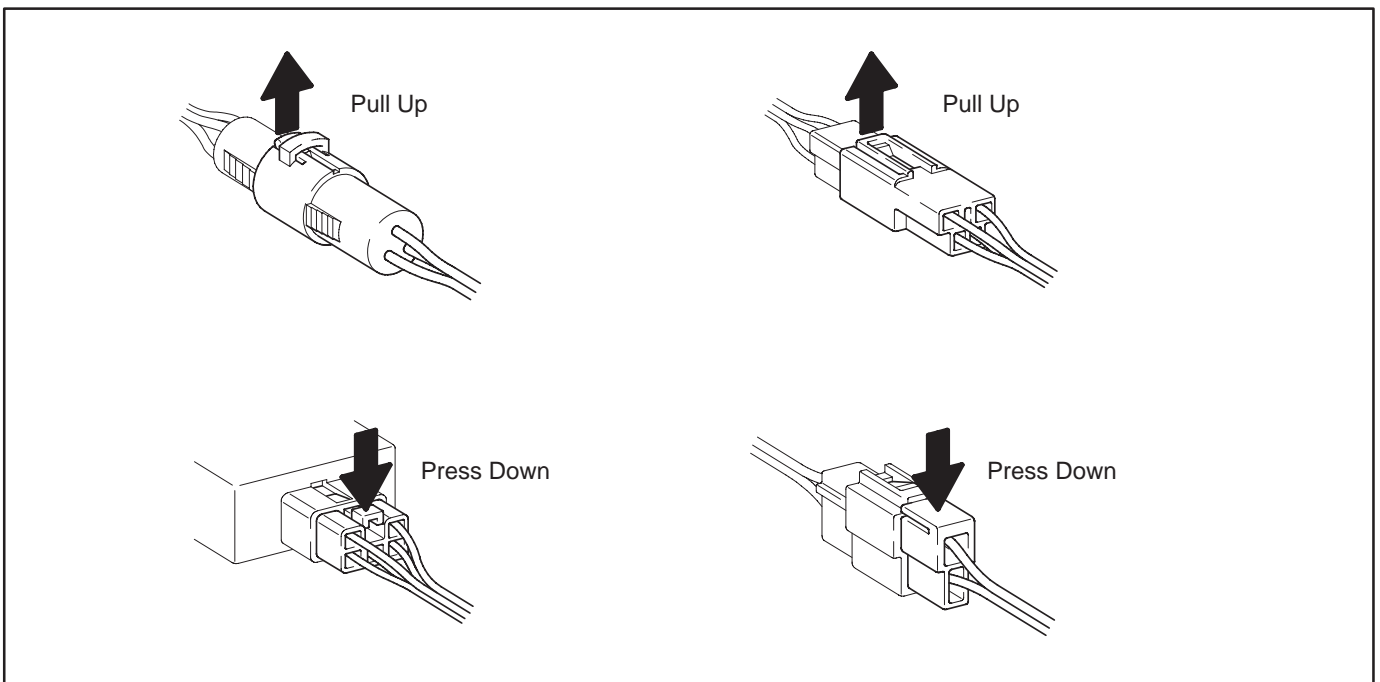

C TROUBLESHOOTING

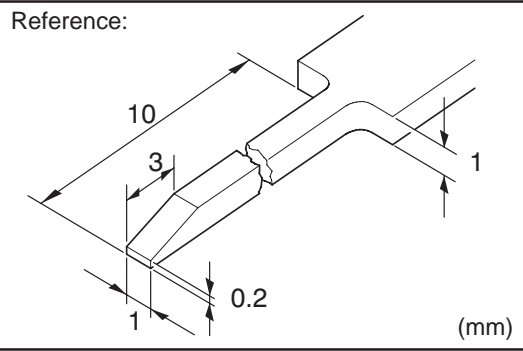

HOW TO REPLACE TERMINAL (with terminal retainer or secondary locking device)

1. PREPARE THE SPECIAL TOOL

HINT : To remove the terminal from the connector, please construct and use the special tool or like object shown on the left.

2. DISCONNECT CONNECTOR

3. DISENGAGE THE SECONDARY LOCKING DEVICE OR TERMINAL RETAINER.

(a) Locking device must be disengaged before the terminal locking clip can be released and the terminal removed from the connector.

(b) Use a special tool or the terminal pick to unlock the secondary locking device or terminal retainer.

NOTICE:

Do not remove the terminal retainer from connector body.

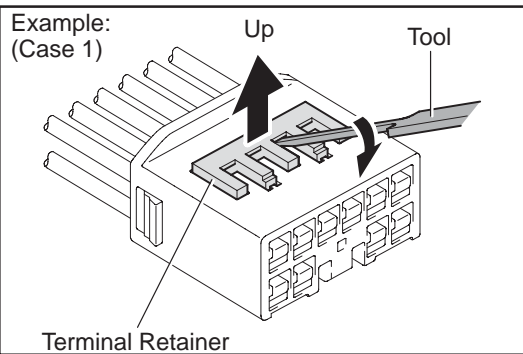

[A] For Non-Waterproof Type Connector

HINT : The needle insertion position varies according to the connector's shape (number of terminals etc.), so check the position before inserting it.

"Case 1"

Raise the terminal retainer up to the temporary lock position.

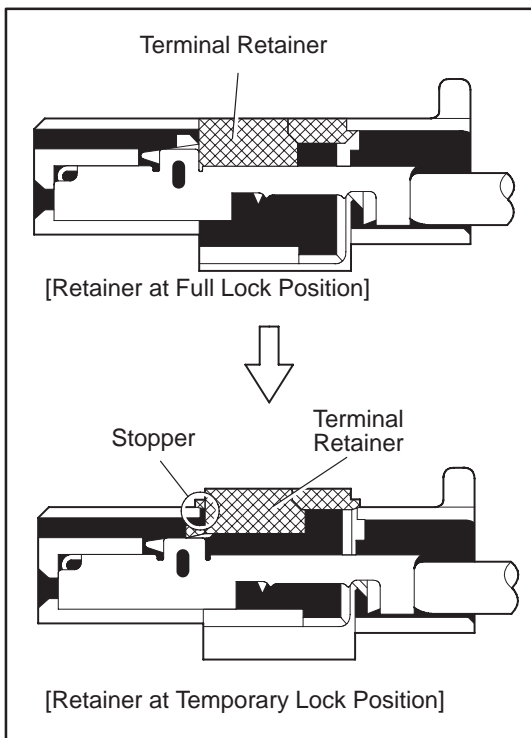

"Case 2"

Open the secondary locking device.

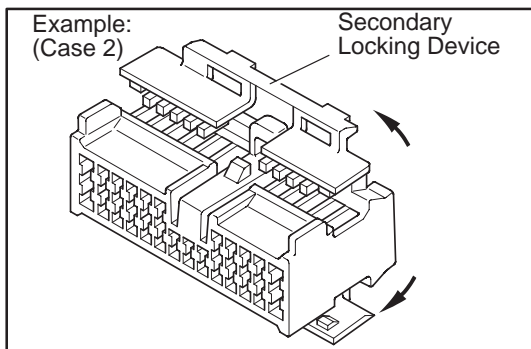

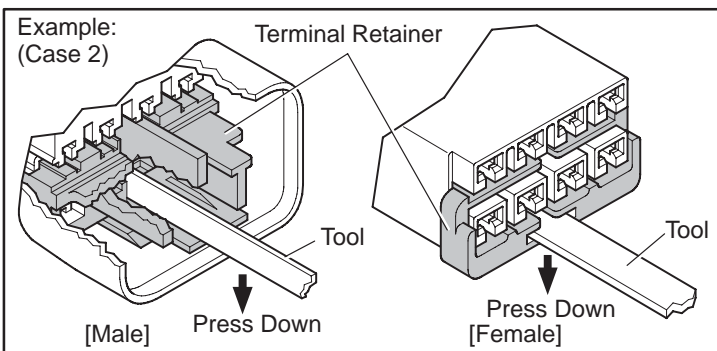
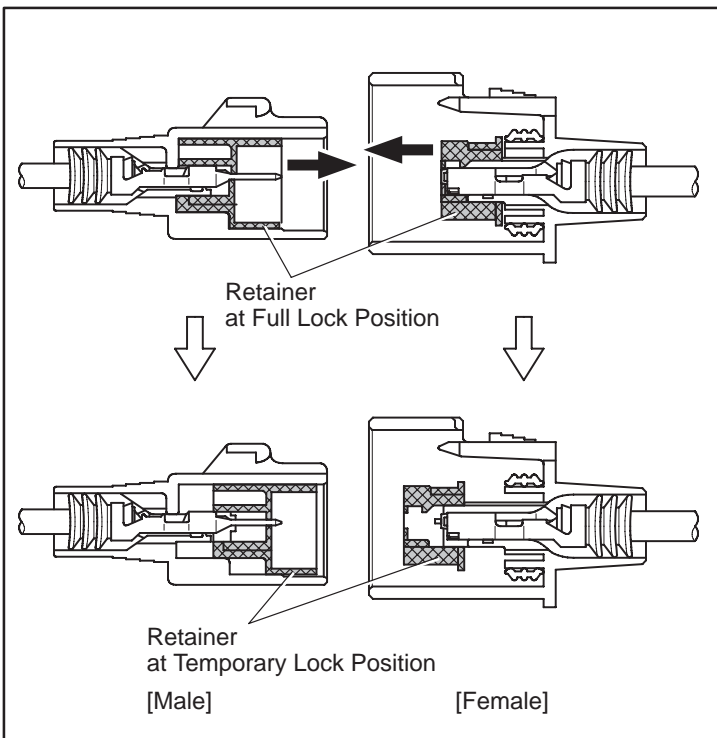
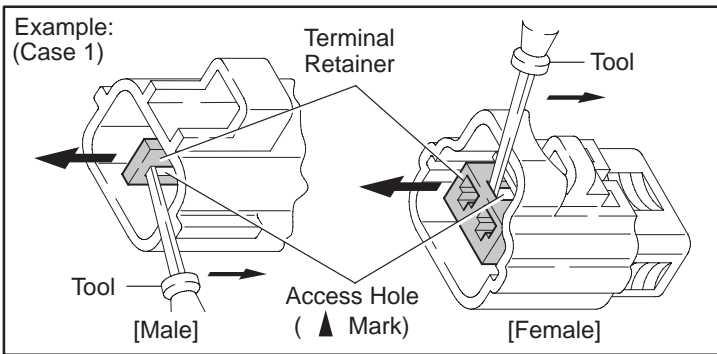
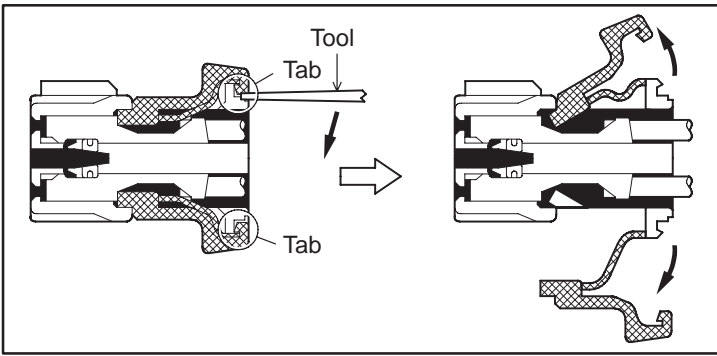

[B] For Waterproof Type Connector

HINT : Terminal retainer color is different according to connector body.

Example:

| Terminal Retainer | Connector Body |
|-------------------|----------------|
| Black or White | Gray |
| Black or White | Dark Gray |
| Gray or White | Black |

"Case 1"

Type where terminal retainer is pulled up to the temporary lock position (Pull Type).

Insert the special tool into the terminal retainer access hole (▲Mark) and pull the terminal retainer up to the temporary lock position.

HINT : The needle insertion position varies according to the connector's shape (Number of terminals etc.), so check the position before inserting it.

"Case 2"

Type which cannot be pulled as far as Power Lock insert the tool straight into the access hole of terminal retainer as shown.

C TROUBLESHOOTING

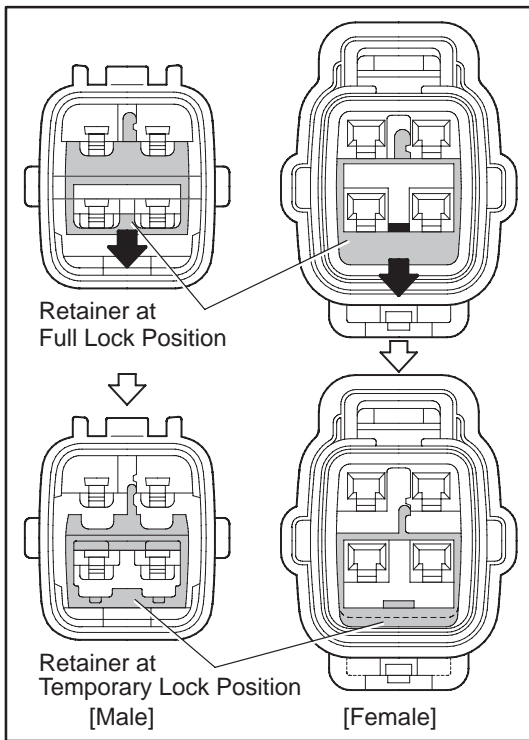

Push the terminal retainer down to the temporary lock position.

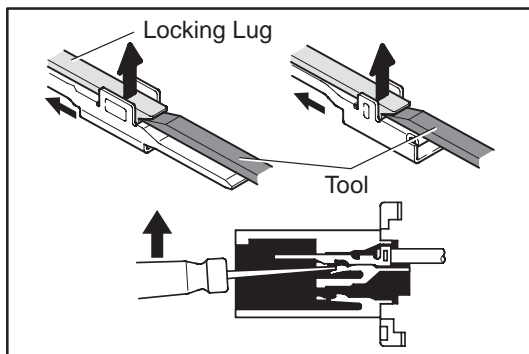

(c) Release the locking lug from terminal and pull the terminal out from rear.

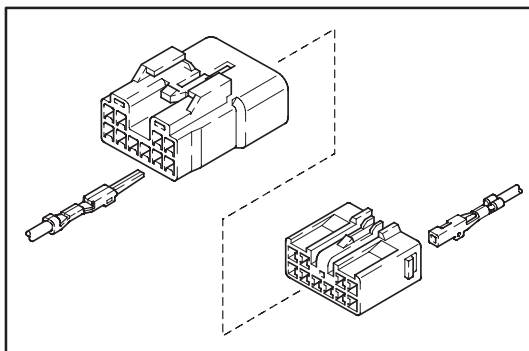

4. INSTALL TERMINAL TO CONNECTOR

(a) Insert the terminal.

HINT:

1. Make sure the terminal is positioned correctly.
2. Insert the terminal until the locking lug locks firmly.
3. Insert the terminal with terminal retainer in the temporary lock position.

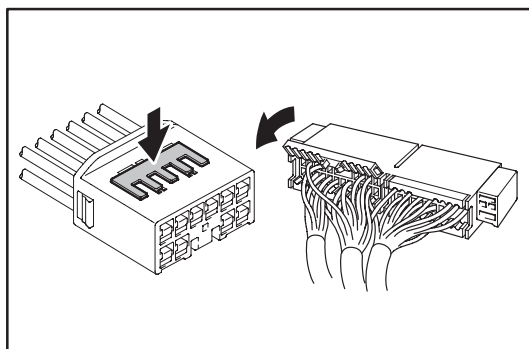

(b) Push the secondary locking device or terminal retainer in to the full lock position.

5. CONNECT CONNECTOR











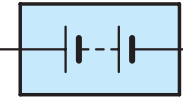

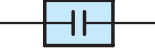





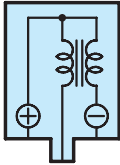

ABBREVIATIONS





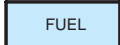

The following abbreviations are used in this manual.

| | | |
|-------|---|-------------------------------------|
| A/C | = | Air Conditioning |
| A/T | = | Automatic Transaxle |
| ABS | = | Anti-Lock Brake System |
| CAN | = | Controller Area Network |
| DEF | = | Defogger |
| ECU | = | Electronic Control Unit |
| ESA | = | Electronic Spark Advance |
| FL | = | Fusible Link |
| IC | = | Integrated Circuit |
| INT | = | Intermittent |
| J/B | = | Junction Block |
| LH | = | Left-Hand |
| M/T | = | Manual Transaxle |
| R/B | = | Relay Block |
| RH | = | Right-Hand |
| SFI | = | Sequential Multiport Fuel Injection |
| SRS | = | Supplemental Restraint System |
| SW | = | Switch |
| TEMP. | = | Temperature |
| TVIP | = | TOYOTA Vehicle Intrusion Protection |
| VSV | = | Vacuum Switching Valve |
| w/ | = | With |
| w/o | = | Without |

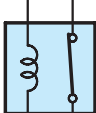
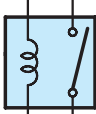
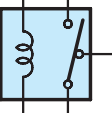
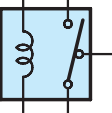
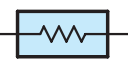
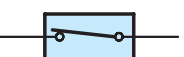
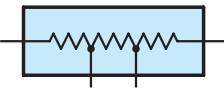
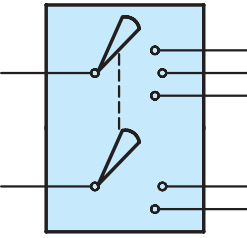
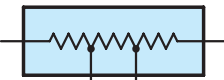
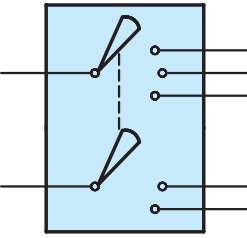
* The titles given inside the components are the names of the terminals (terminal codes) and are not treated as being abbreviations.

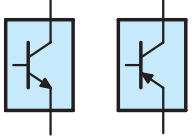
E GLOSSARY OF TERMS AND SYMBOLS

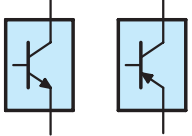
| | |
|---|---|
|  <p>BATTERY Stores chemical energy and converts it into electrical energy. Provides DC current for the auto's various electrical circuits.</p> |  <p>GROUND The point at which wiring attaches to the Body, thereby providing a return path for an electrical circuit; without a ground, current cannot flow.</p> |
|  <p>CAPACITOR (Condenser) A small holding unit for temporary storage of electrical voltage.</p> | <p>HEADLIGHTS Current flow causes a headlight filament to heat up and emit light. A headlight may have either a single (1) filament or a double (2) filament</p> <p>1. SINGLE FILAMENT </p> <p>2. DOUBLE FILAMENT </p> |
|  <p>CIGARETTE LIGHTER An electric resistance heating element.</p> | |
|  <p>CIRCUIT BREAKER Basically a reusable fuse, a circuit breaker will heat and open if too much current flows through it. Some units automatically reset when cool, others must be manually reset.</p> |  <p>HORN An electric device which sounds a loud audible signal.</p> |
|  <p>DIODE A semiconductor which allows current flow in only one direction.</p> |  <p>IGNITION COIL Converts low-voltage DC current into high-voltage ignition current for firing the spark plugs.</p> |
|  <p>DIODE, ZENER A diode which allows current flow in one direction but blocks reverse flow only up to a specific voltage. Above that potential, it passes the excess voltage. This acts as a simple voltage regulator.</p> |  <p>LIGHT Current flow through a filament causes the filament to heat up and emit light.</p> |
|  <p>PHOTODIODE The photodiode is a semiconductor which controls the current flow according to the amount of light.</p> |  <p>LED (LIGHT EMITTING DIODE) Upon current flow, these diodes emit light without producing the heat of a comparable light.</p> |
|  <p>DISTRIBUTOR, IIA Channels high-voltage current from the ignition coil to the individual spark plugs.</p> |  <p>METER, ANALOG Current flow activates a magnetic coil which causes a needle to move, thereby providing a relative display against a background calibration.</p> |
|  <p>FUSE A thin metal strip which burns through when too much current flows through it, thereby stopping current flow and protecting a circuit from damage.</p>  <p>FUSIBLE LINK (for Medium Current Fuse) A heavy-gauge wire placed in high amperage circuits which burns through on overloads, thereby protecting the circuit. The numbers indicate the cross-section surface area of the wires.</p>  <p>(for High Current Fuse or Fusible Link)</p> |  <p>METER, DIGITAL Current flow activates one or many LED's, LCD's, or fluorescent displays, which provide a relative or digital display.</p> |
| |  <p>MOTOR A power unit which converts electrical energy into mechanical energy, especially rotary motion.</p> |

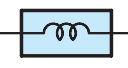
| | |
|--|---|
|  <p>RELAY Basically, an electrically operated switch which may be normally closed (1) or open (2). Current flow through a small coil creates a magnetic field which either opens or closes an attached switch.</p> <p>1. NORMALLY CLOSED</p> <p>2. NORMALLY OPEN</p> |  <p>SPEAKER An electromechanical device which creates sound waves from current flow.</p> |
|  <p>RELAY, DOUBLE THROW A relay which passes current through one set of contacts or the other.</p> | <p>SWITCH, MANUAL Opens and closes circuits, thereby stopping (1) or allowing (2) current flow.</p>  <p>1. NORMALLY OPEN</p> <p>2. NORMALLY CLOSED</p> |
|  <p>RESISTOR An electrical component with a fixed resistance, placed in a circuit to reduce voltage to a specific value.</p> | <p>SWITCH, DOUBLE THROW A switch which continuously passes current through one set of contacts or the other.</p>  |
|  <p>RESISTOR, TAPPED A resistor which supplies two or more different non adjustable resistance values.</p> | <p>SWITCH, IGNITION A key operated switch with several positions which allows various circuits, particularly the primary ignition circuit, to become operational.</p>  |
|  <p>RESISTOR, VARIABLE or RHEOSTAT A controllable resistor with a variable rate of resistance. Also called a potentiometer or rheostat.</p> | <p>SWITCH, WIPER PARK Automatically returns wipers to the stop position when the wiper switch is turned off.</p>  |
|  <p>SENSOR (Thermistor) A resistor which varies its resistance with temperature.</p> | <p>TRANSISTOR A solidstate device typically used as an electronic relay; stops or passes current depending on the voltage applied at "base".</p>  |
|  <p>SENSOR, SPEED Uses magnetic impulses to open and close a switch to create a signal for activation of other components. (Reed Switch Type)</p> | <p>WIRES Wires are always drawn as straight lines on wiring diagrams. Crossed wires (1) without a black dot at the junction are not joined; crossed wires (2) with a black dot or octagonal (○) mark at the junction are spliced (joined) connections.</p>  <p>(1) NOT CONNECTED</p> <p>(2) SPLICED</p> |
|  <p>SHORT PIN Used to provide an unbroken connection within a junction block.</p> | |
|  <p>SOLENOID An electromagnetic coil which forms a magnetic field when current flows, to move a plunger, etc.</p> | |

F RELAY LOCATIONS

[Engine Compartment]

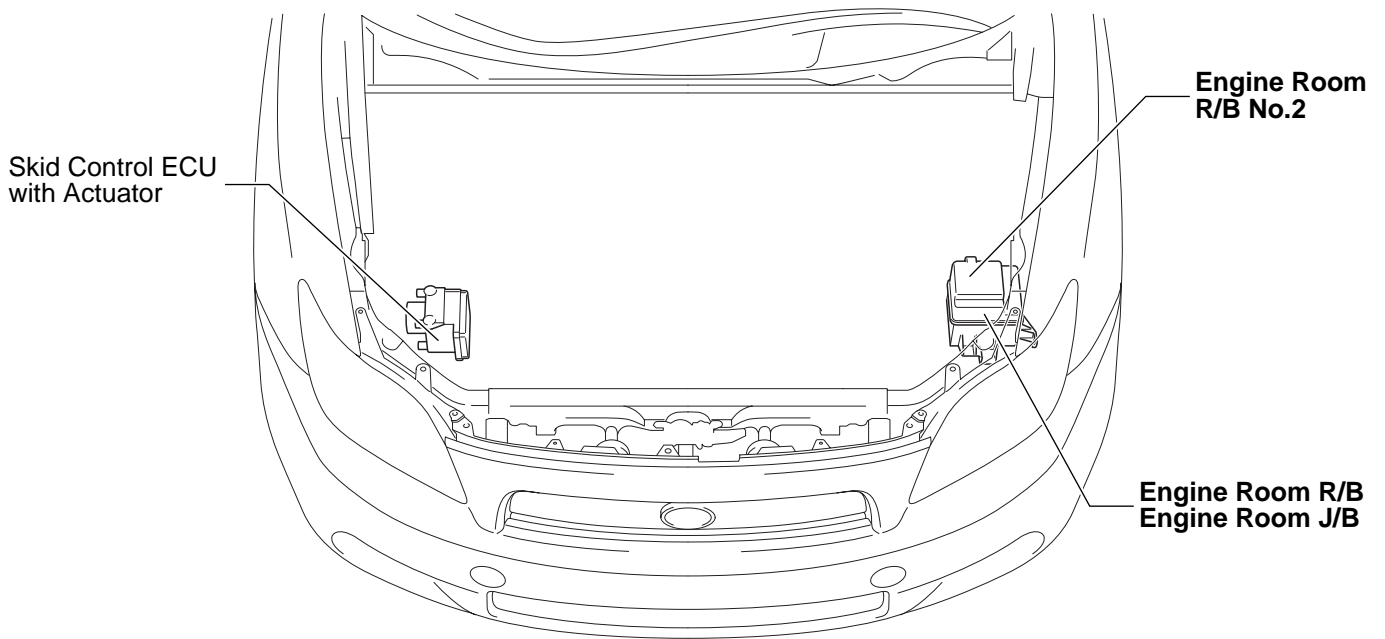

[Body]

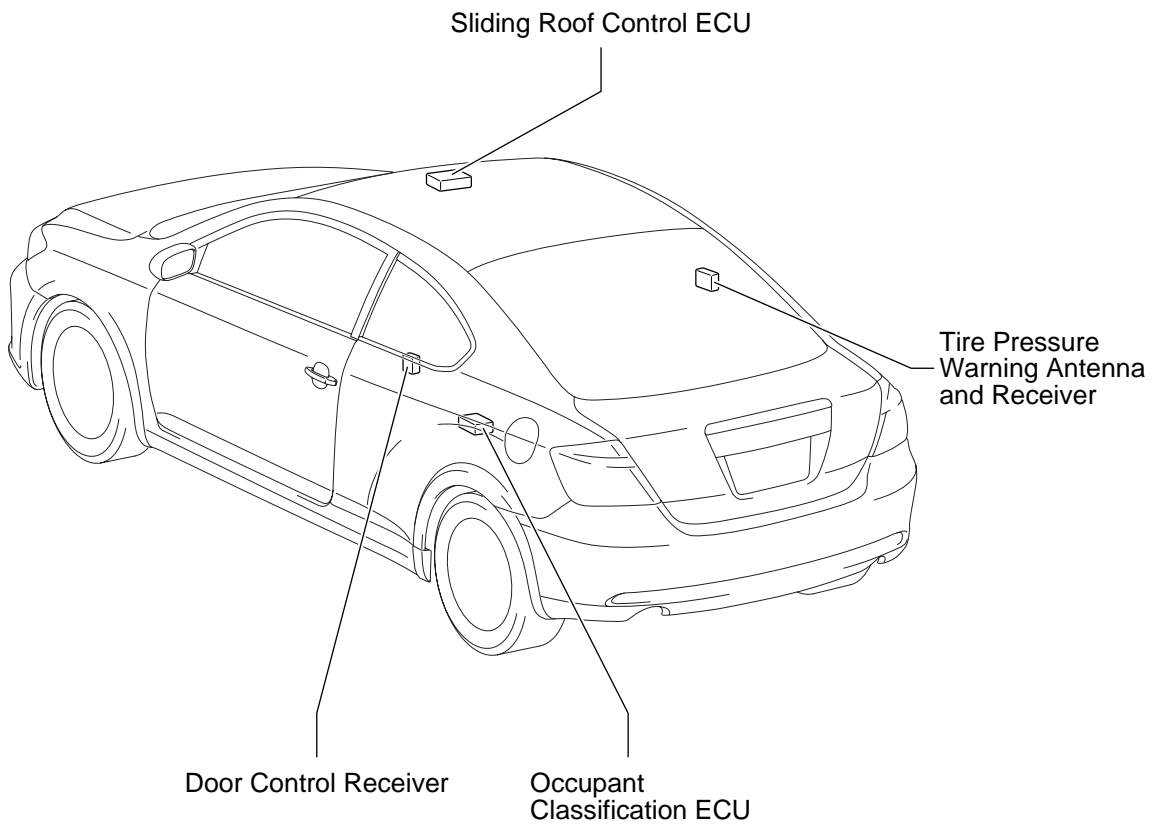

[Instrument Panel]

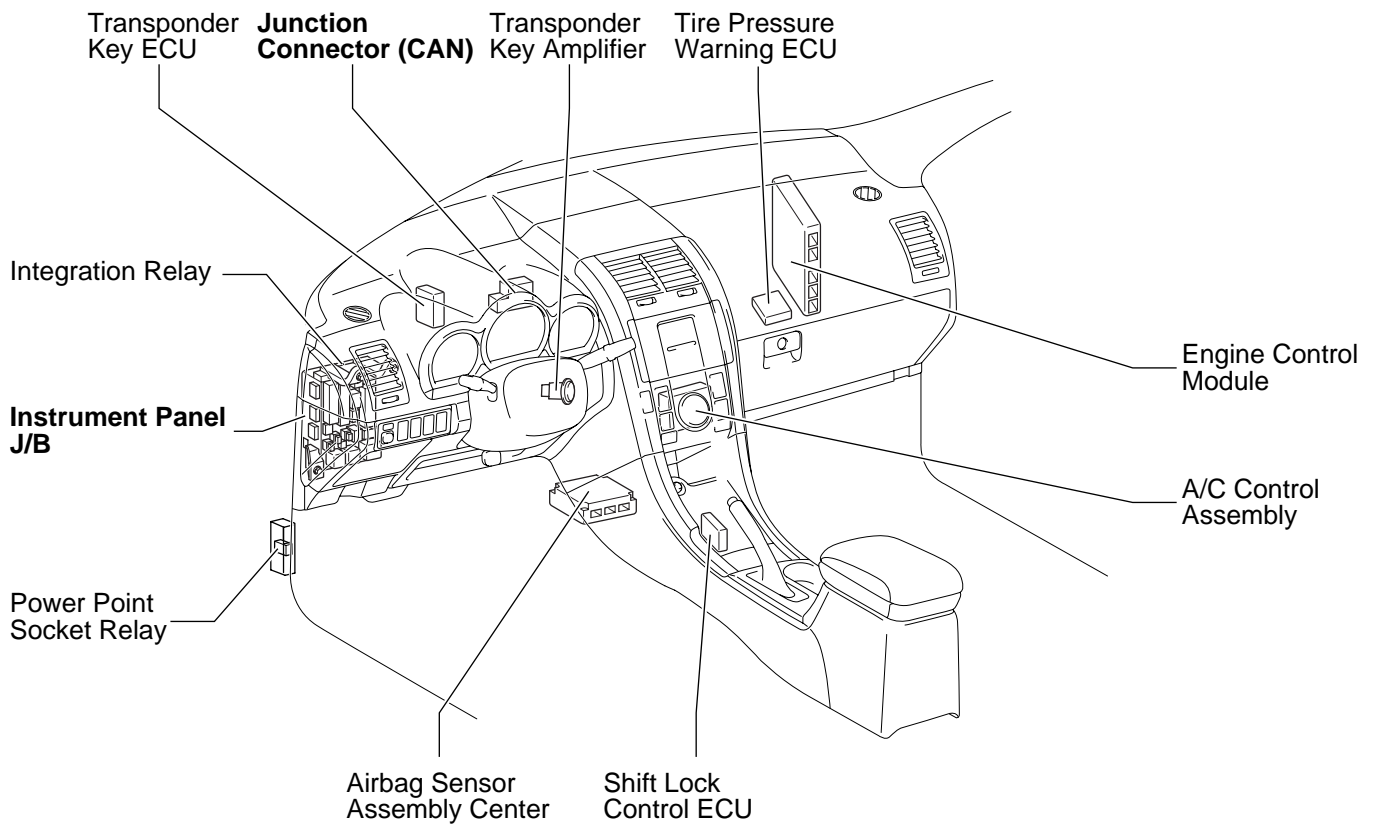

③ : Engine Room R/B No.2 | Inside of the Engine Room R/B Box (See Page 20)

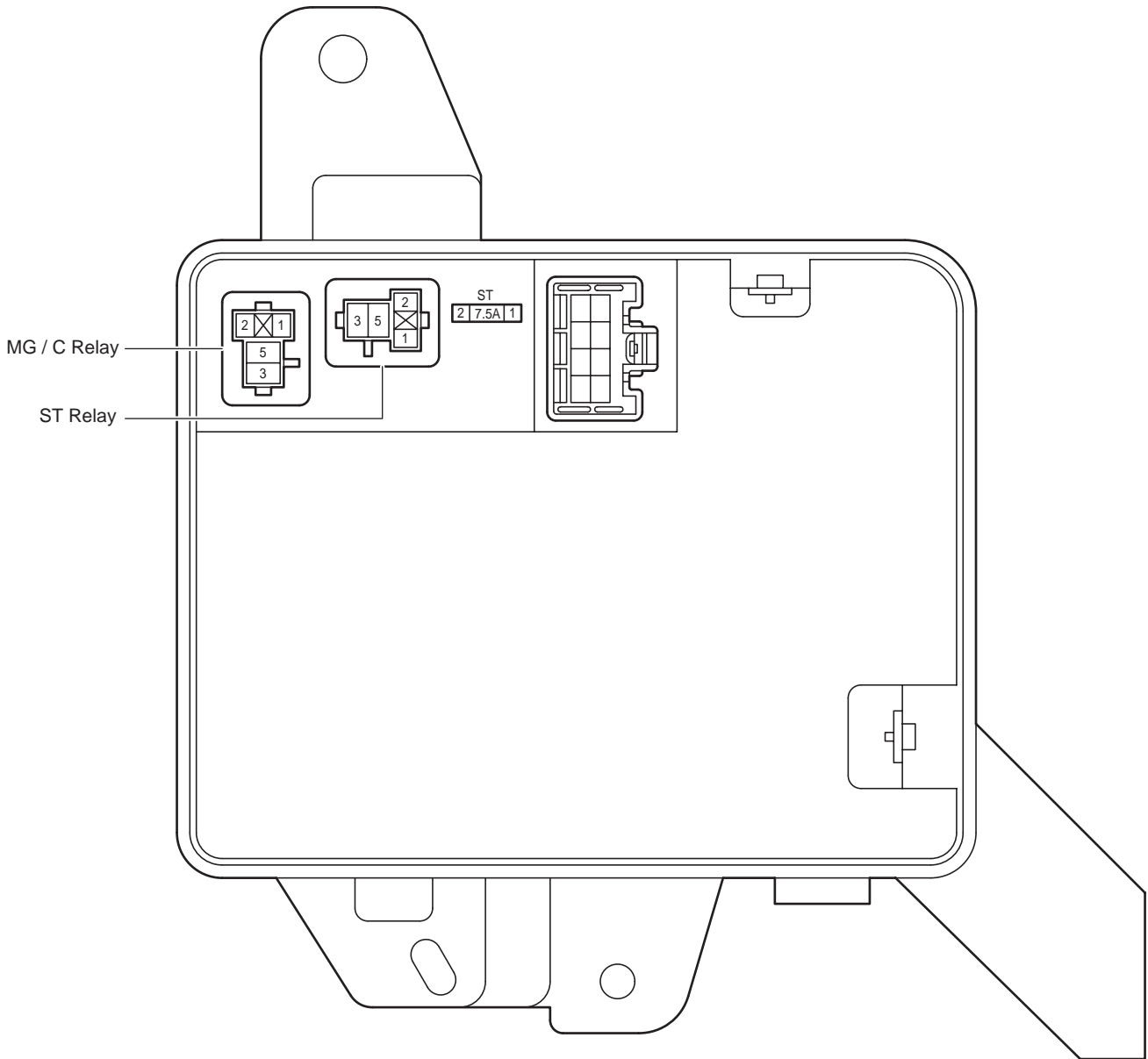

F RELAY LOCATIONS

○ : Instrument Panel J/B **Lower Finish Panel (See Page 21)**

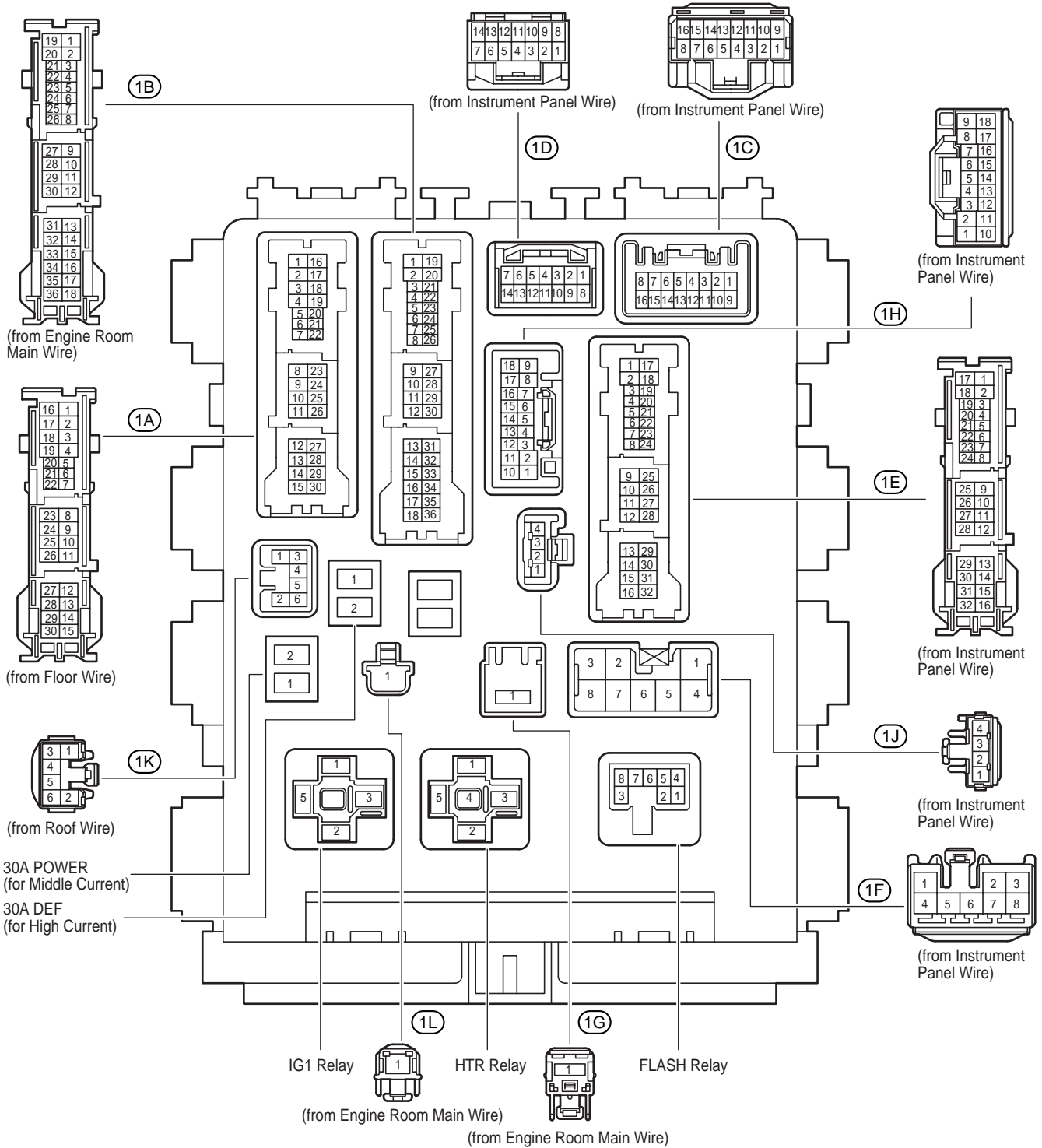

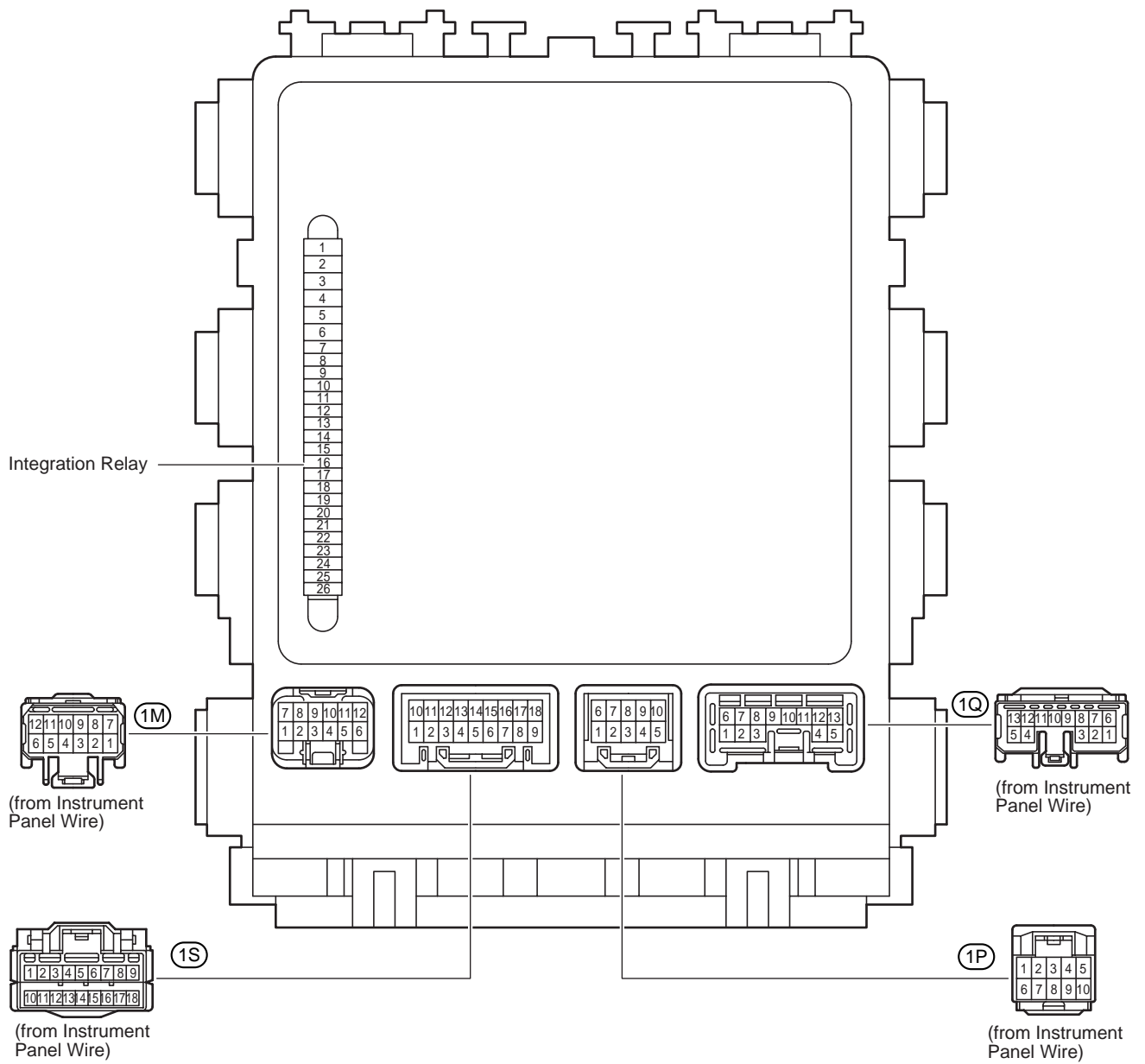

F RELAY LOCATIONS

○ : Instrument Panel J/B Lower Finish Panel (See Page 21)

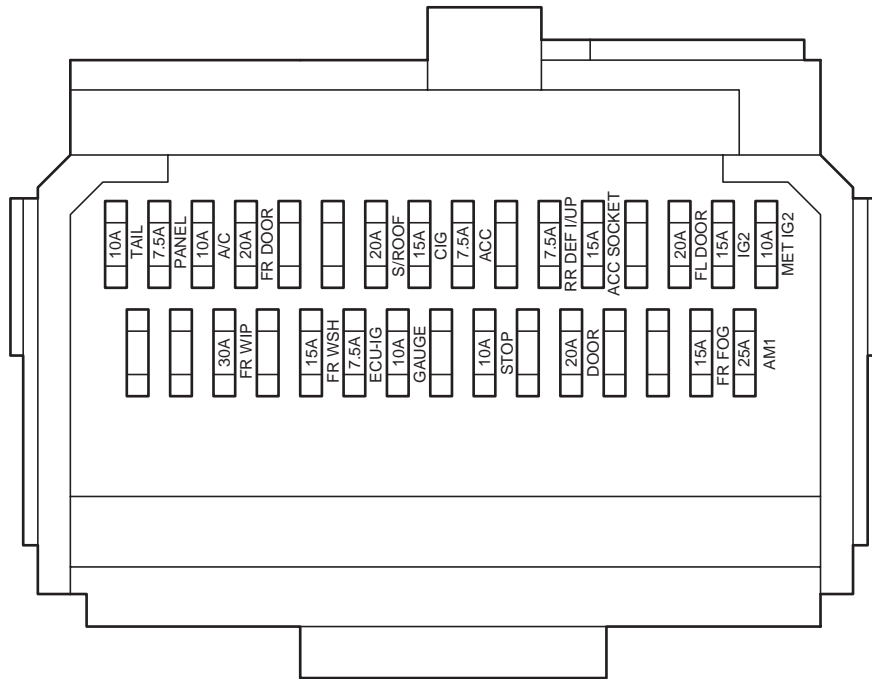

F RELAY LOCATIONS

[Instrument Panel J/B Inner Circuit]

* 1:w/ Jam Protection
 * 2:w/o Jam Protection

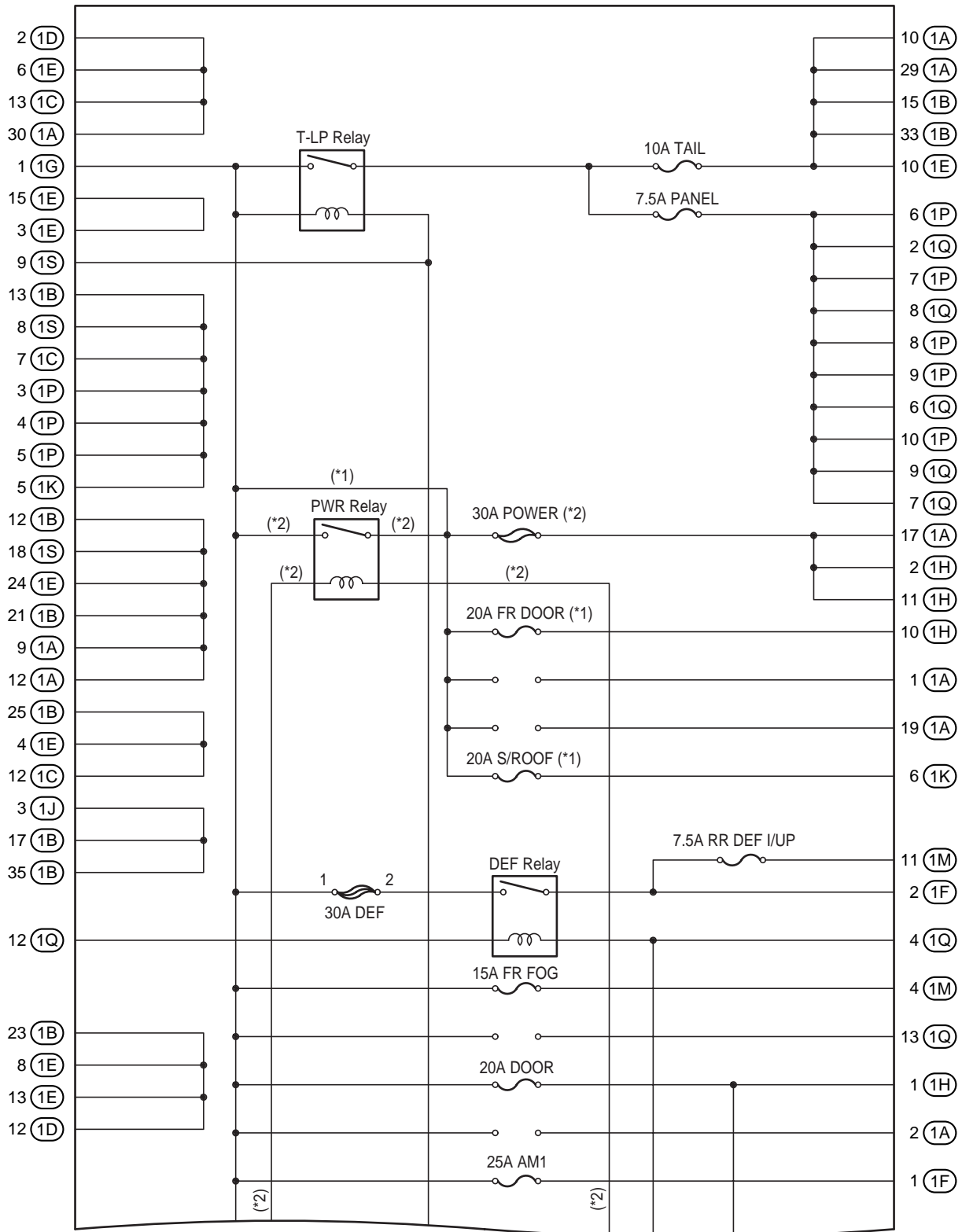

(Cont. Next Page)

* 2:w/o Jam Protection

(Cont'd)

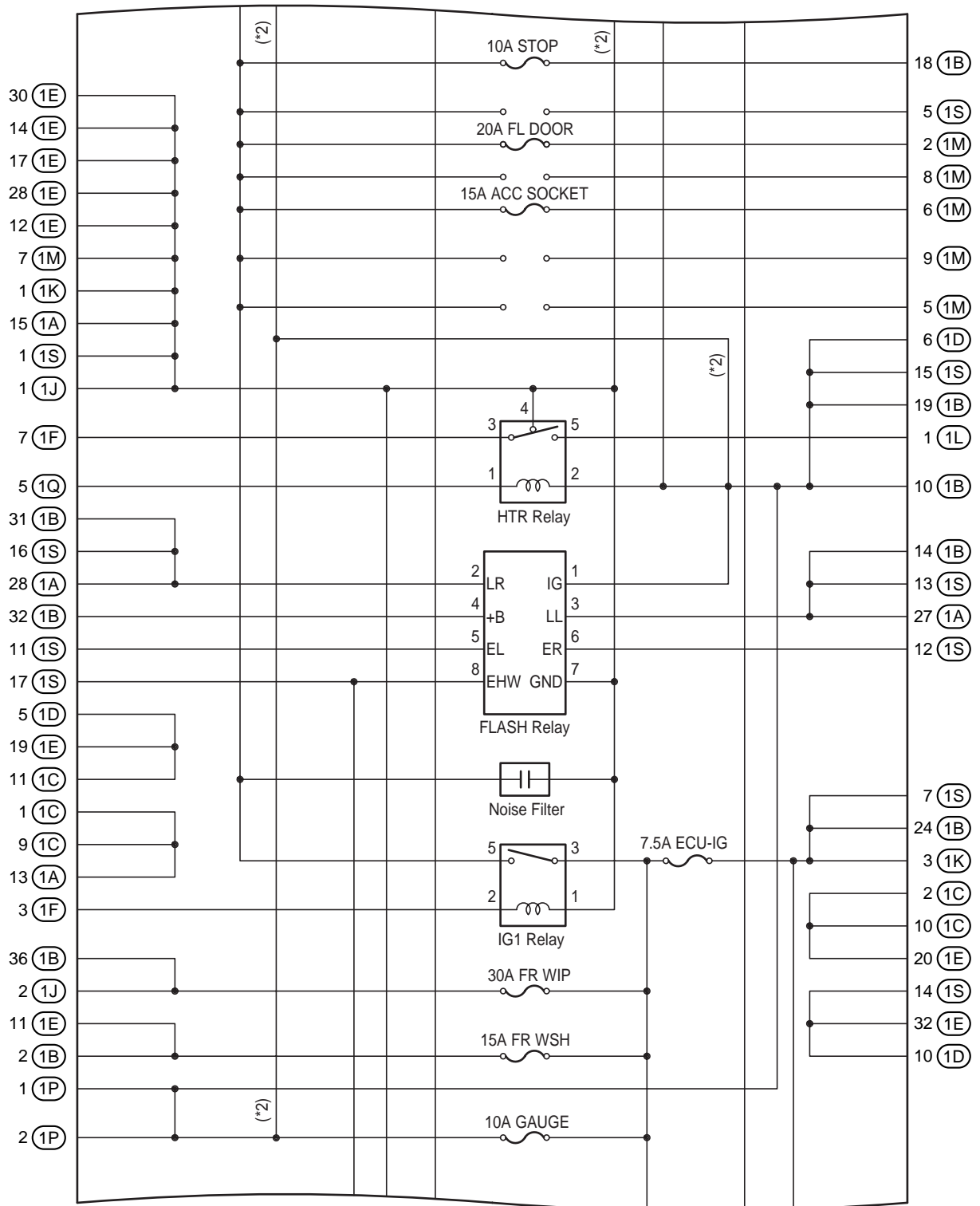

(Cont. Next Page)

F RELAY LOCATIONS

[Instrument Panel J/B Inner Circuit]

(Cont'd)

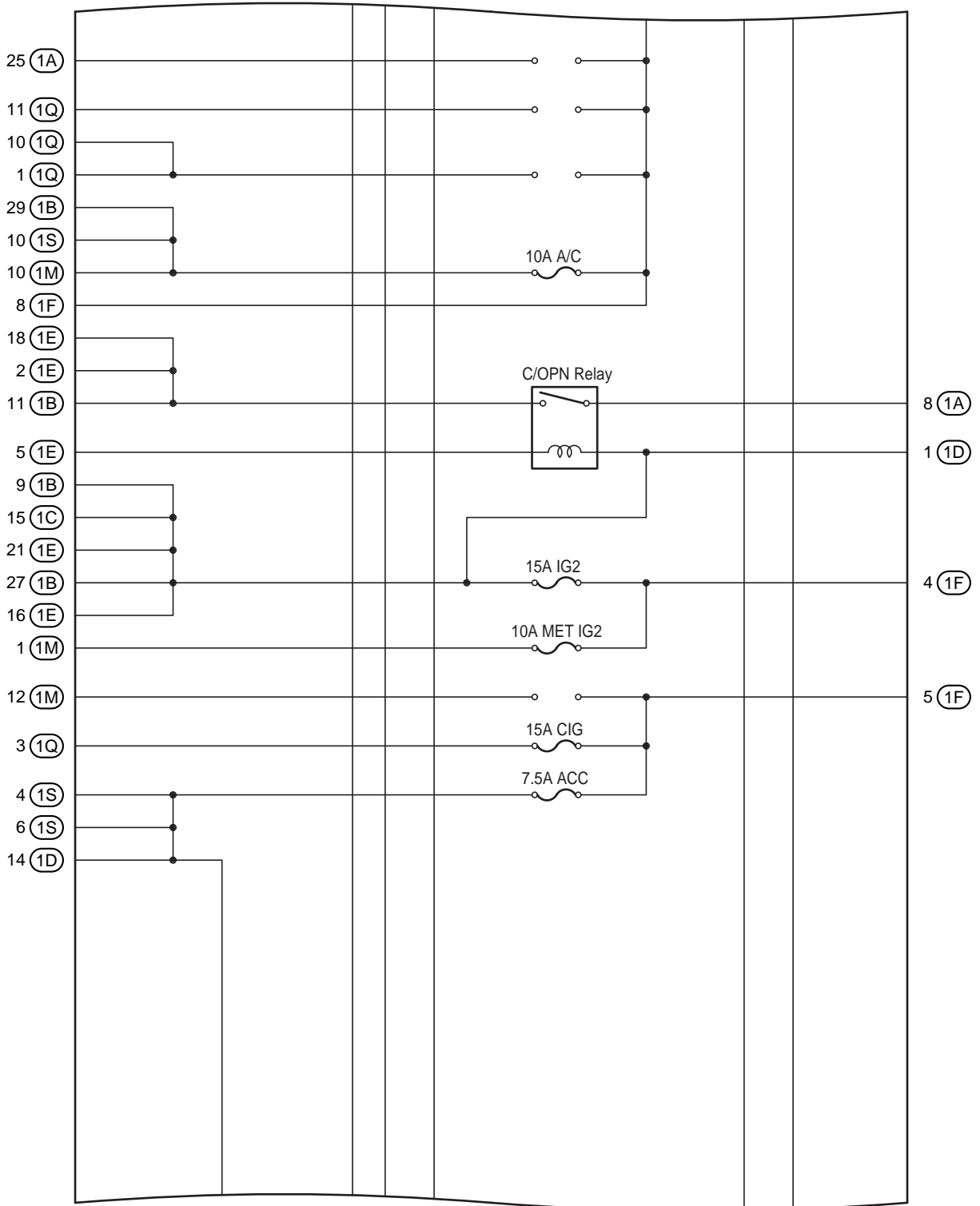

(Cont. Next Page)

(Cont'd)

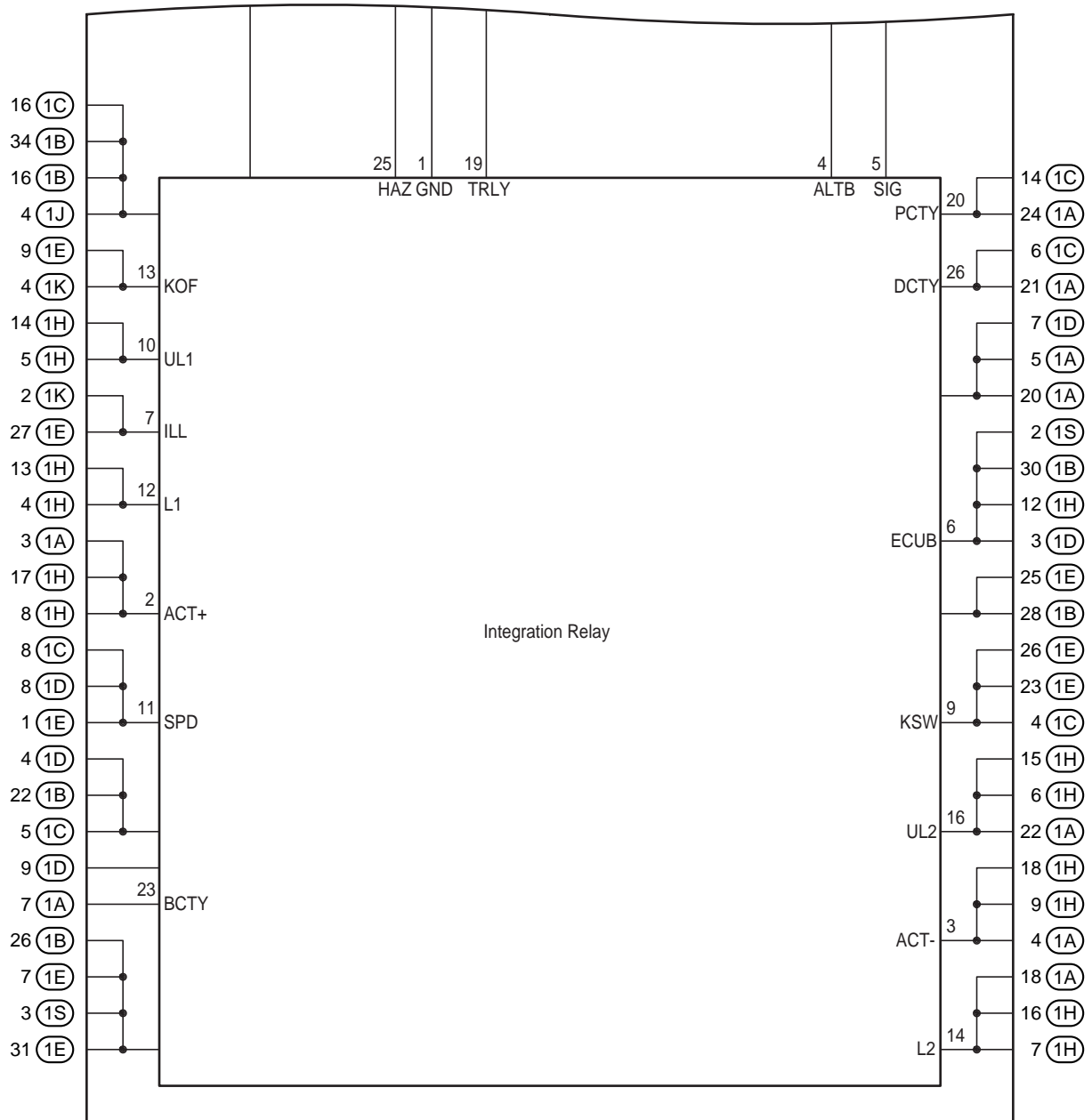

F RELAY LOCATIONS

Junction Connector
(CAN)

Behind of the Combination Meter (See Page 21)

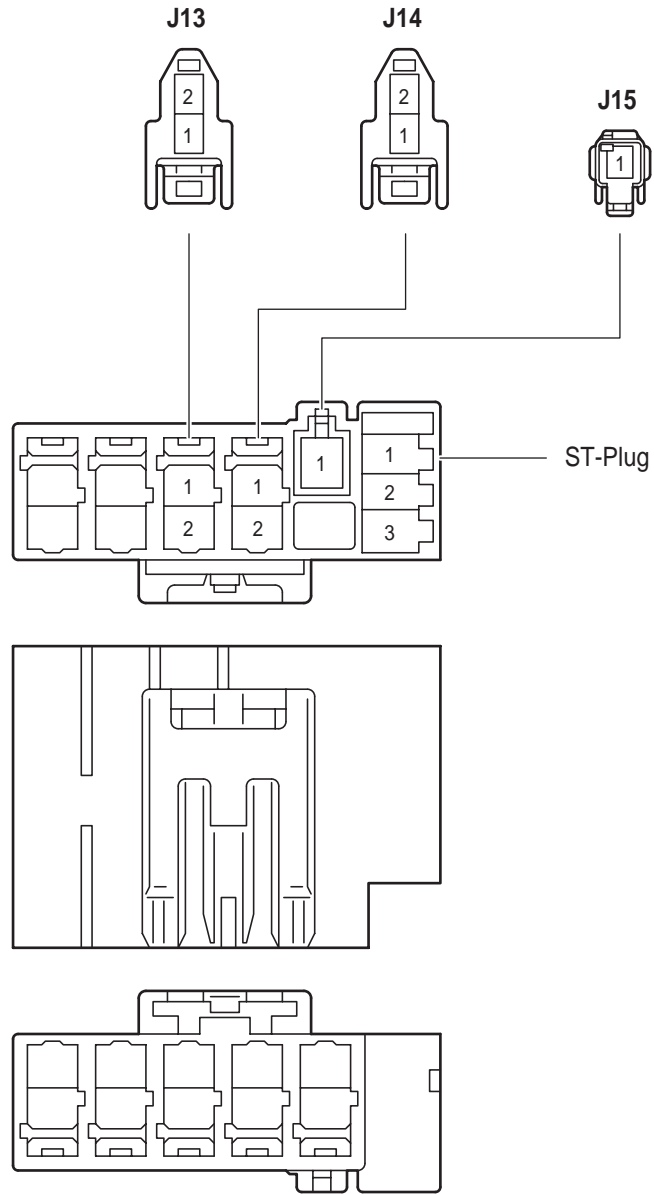

[Junction Connector Inner Circuit]
(CAN)

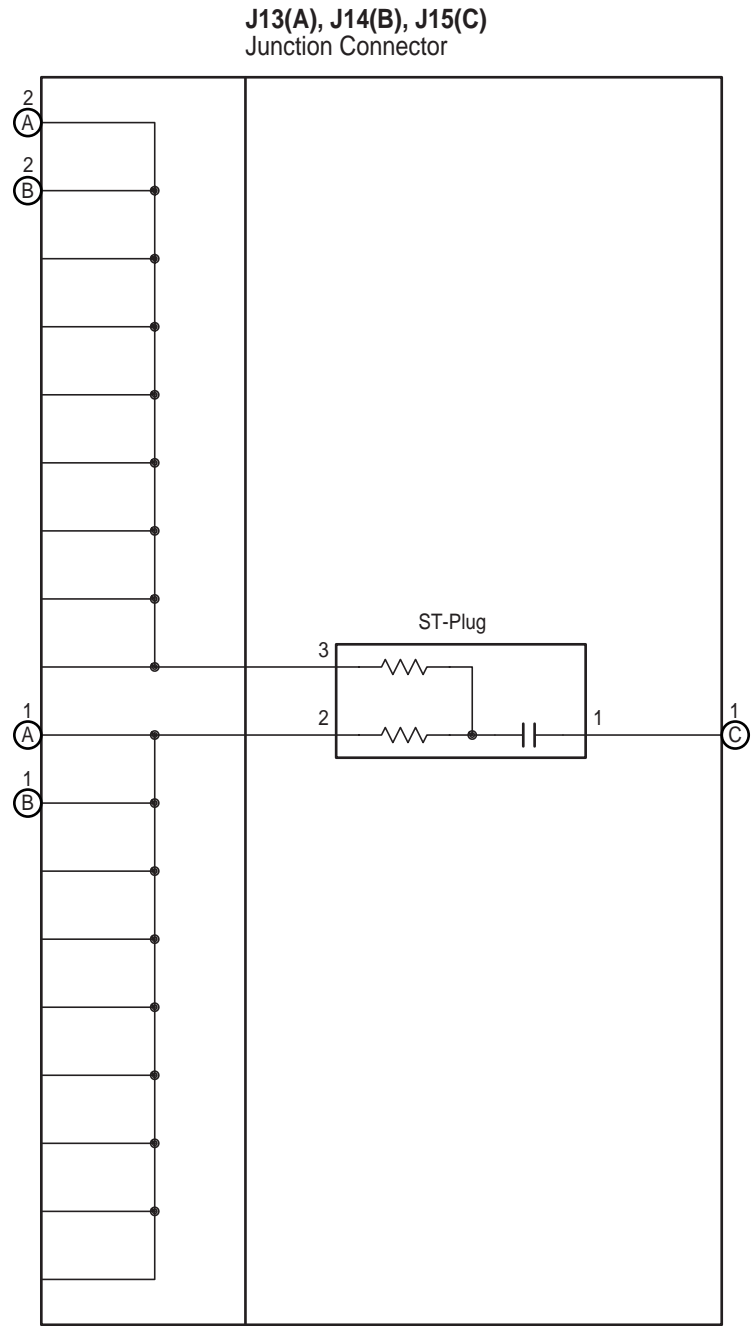

G ELECTRICAL WIRING ROUTING

Position of Parts in Engine Compartment

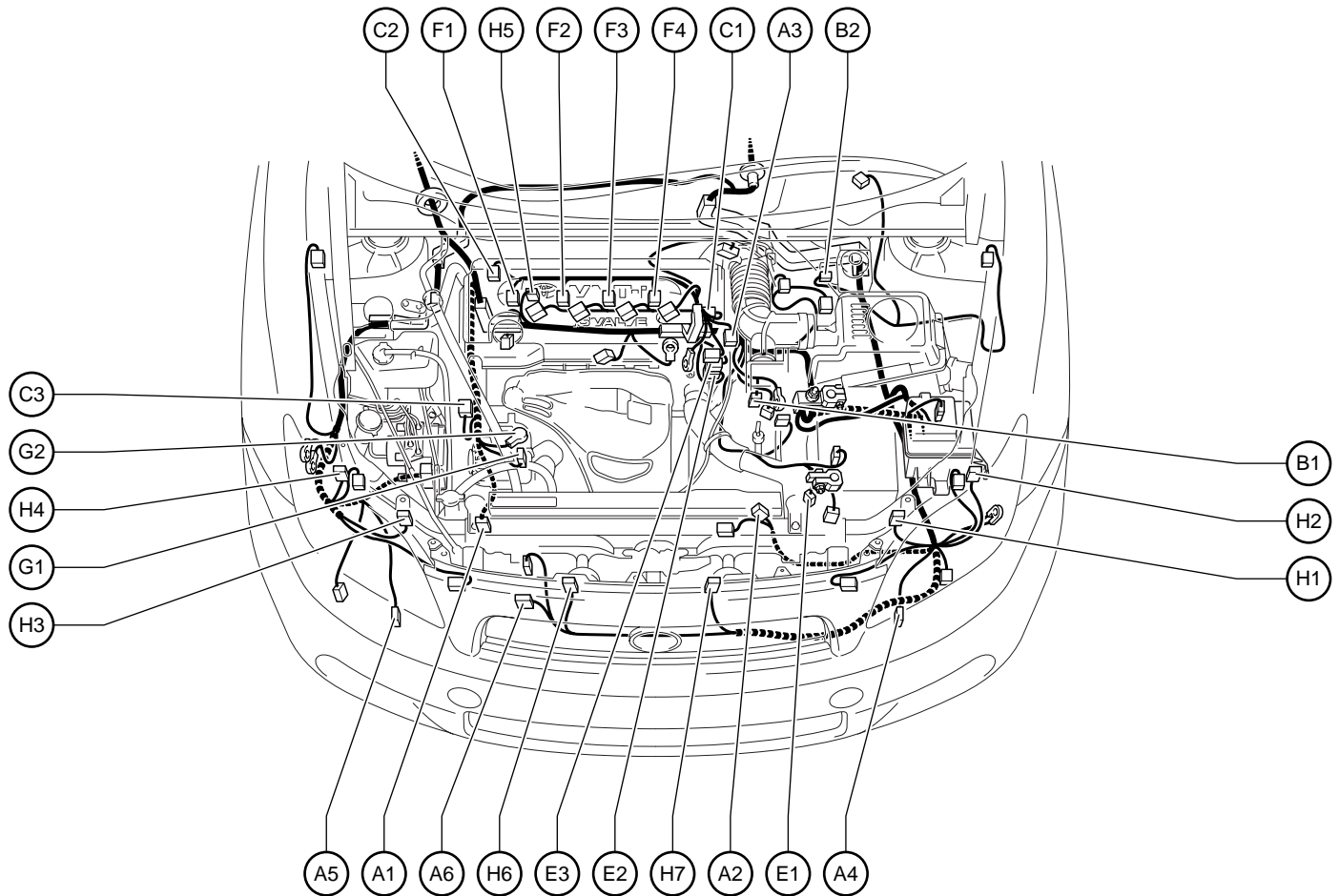

- | | |
|---|--|
| A 1 A/C Compressor | F 1 Fuel Injector (No.1) |
| A 2 A/C Condenser Fan Motor | F 2 Fuel Injector (No.2) |
| A 3 Air Fuel Ratio Sensor (Bank 1 Sensor 1) | F 3 Fuel Injector (No.3) |
| A 4 Airbag Sensor (Front LH) | F 4 Fuel Injector (No.4) |
| A 5 Airbag Sensor (Front RH) | G 1 Generator |
| A 6 Ambient Temp. Sensor | G 2 Generator |
| B 1 Back-Up Lamp SW | H 1 Headlamp (LH High) |
| B 2 Brake Fluid Level Warning SW | H 2 Headlamp (LH Low) |
| C 1 Camshaft Position Sensor | H 3 Headlamp (RH High) |
| C 2 Camshaft Timing Oil Control Valve | H 4 Headlamp (RH Low) |
| C 3 Crankshaft Position Sensor | H 5 Heated Oxygen Sensor (Bank 1 Sensor 2) |
| E 1 Electronically Controlled Transmission Solenoid | H 6 Horn (Low) |
| E 2 Engine Coolant Temp. Sensor | H 7 Horn (High) |
| E 3 Engine Oil Pressure SW | |

Position of Parts in Engine Compartment

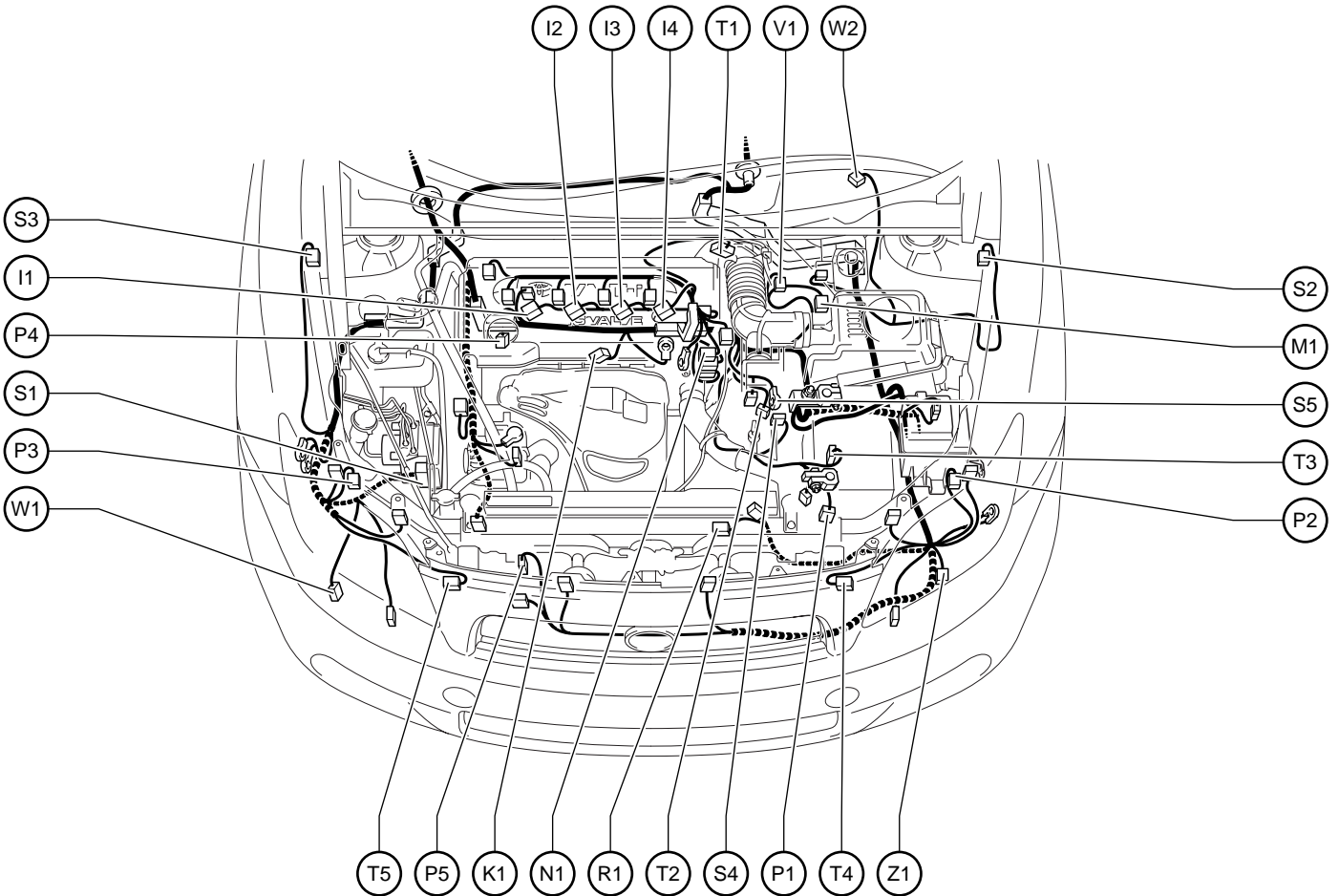

I 1 Ignition Coil (No.1)
 I 2 Ignition Coil (No.2)
 I 3 Ignition Coil (No.3)
 I 4 Ignition Coil (No.4)

K 1 Knock Control Sensor (Bank 1)

M 1 Mass Air Flow Meter

N 1 Noise Filter (Ignition)

P 1 Park/Neutral Position SW

P 2 Parking Lamp (LH)

P 3 Parking Lamp (RH)

P 4 Power Steering Oil Pressure SW

P 5 Pressure SW

R 1 Radiator Fan Motor

S 1 Skid Control ECU with Actuator

S 2 Speed Sensor (Front LH)

S 3 Speed Sensor (Front RH)

S 4 Starter

S 5 Starter

T 1 Throttle Body Assembly

T 2 Transmission Revolution Sensor (Counter Gear)

T 3 Transmission Revolution Sensor (Turbine)

T 4 Turn Signal Lamp (Front LH)

T 5 Turn Signal Lamp (Front RH)

V 1 VSV (Purge)

W 1 Windshield Washer Motor

W 2 Windshield Wiper Motor

Z 1 Option Connector (Front Fog Lamp)

G ELECTRICAL WIRING ROUTING

Position of Parts in Instrument Panel

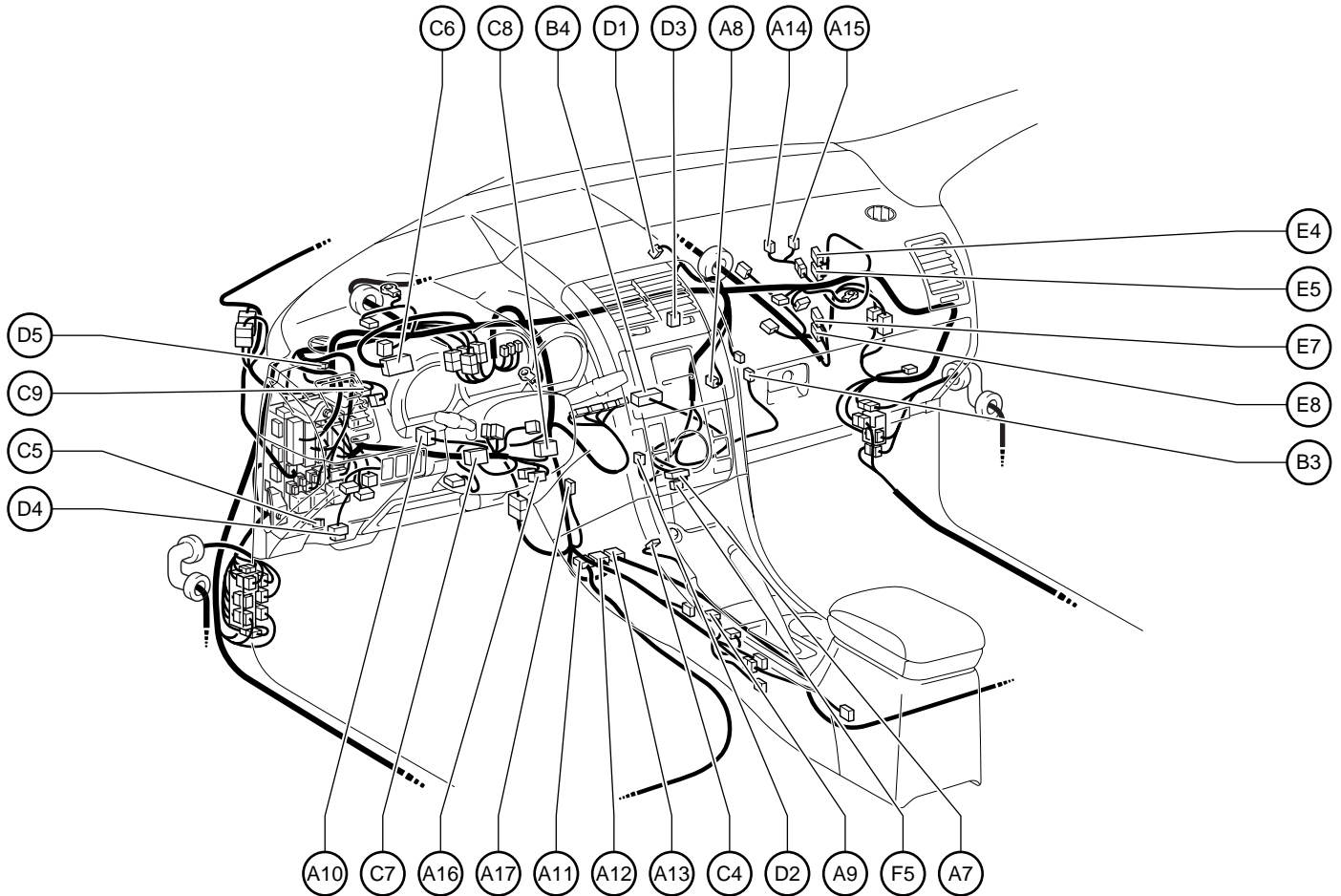

- | | |
|--|--|
| A 7 A/C Control Assembly | D 1 Damper Servo Motor (Air Inlet) |
| A 8 A/C Thermistor No.1 | D 2 Damper Servo Motor (Air Mix) |
| A 9 A/T Shift Lever Illumination | D 3 Damper Servo Motor (Air Vent Mode) |
| A10 Accelerator Position Sensor | D 4 Data Link Connector 3 |
| A11 Airbag Sensor Assembly Center | D 5 Diode (Fan) |
| A12 Airbag Sensor Assembly Center | E 4 Engine Control Module |
| A13 Airbag Sensor Assembly Center | E 5 Engine Control Module |
| A14 Airbag Squib (Front Passenger's Airbag Assembly) | E 7 Engine Control Module |
| A15 Airbag Squib (Front Passenger's Airbag Assembly) | E 8 Engine Control Module |
| A16 Airbag Squib (Steering Wheel Pad) | F 5 Front Console Illumination |
| A17 Antenna Amplifier | |
| B 3 Blower Motor | |
| B 4 Blower Motor Control | |
| C 4 Cigarette Lighter | |
| C 5 Clutch Start SW | |
| C 6 Combination Meter | |
| C 7 Combination SW | |
| C 8 Combination SW | |
| C 9 Cruise Control Clutch SW | |

Position of Parts in Instrument Panel

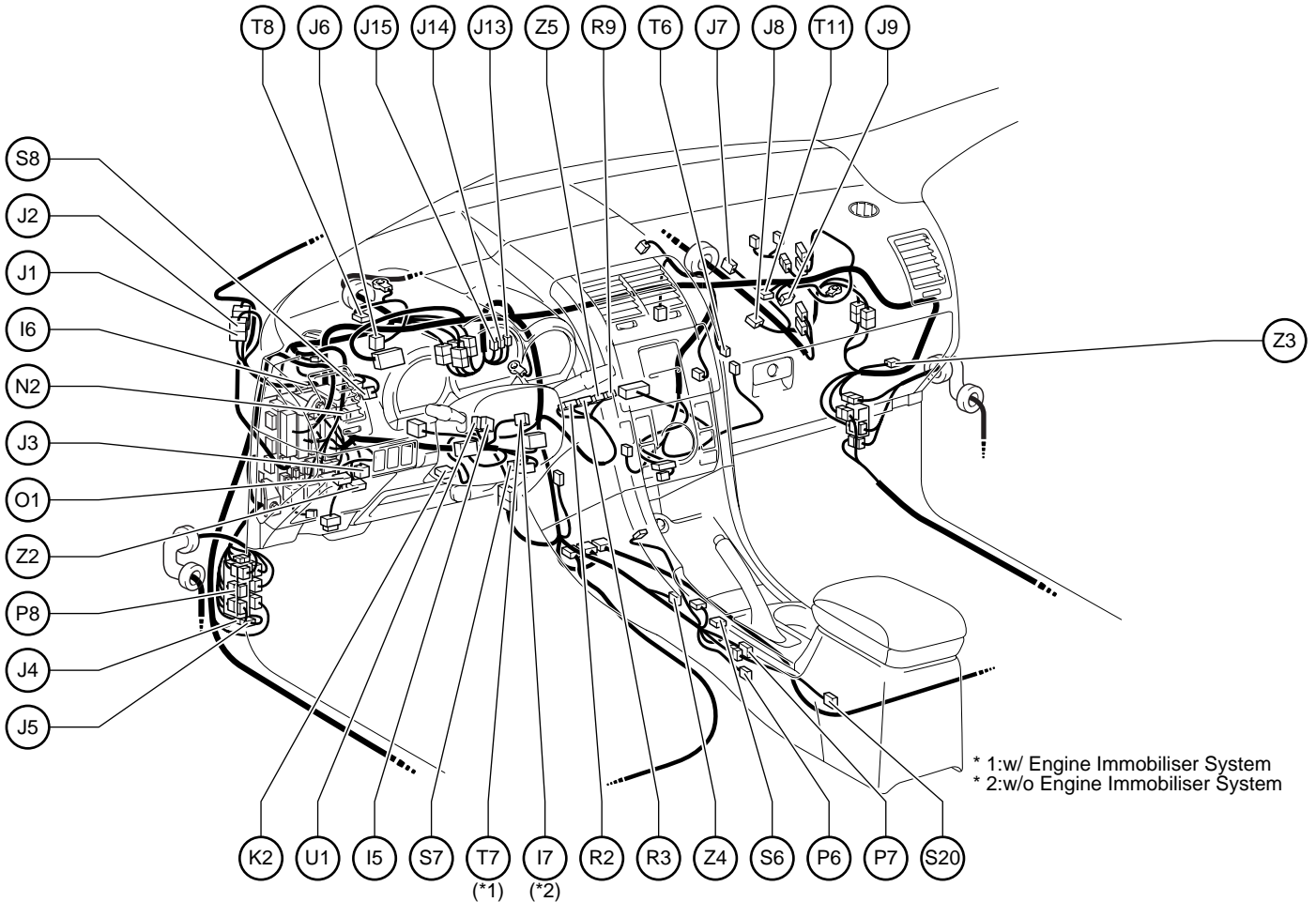

I 5 Ignition SW
I 6 Integration Relay
I 7 Ignition Cylinder Lamp

P 6 Parking Brake SW
P 7 Power Point Socket
P 8 Power Point Socket Relay

J 1 Junction Connector
J 2 Junction Connector
J 3 Junction Connector
J 4 Junction Connector
J 5 Junction Connector
J 6 Junction Connector
J 7 Junction Connector
J 8 Junction Connector
J 9 Junction Connector
J 13 Junction Connector
J 14 Junction Connector
J 15 Junction Connector

R 2 Radio Receiver Assembly
R 3 Radio Receiver Assembly
R 9 Radio Receiver Assembly

S 6 Shift Lock Control ECU
S 7 Spiral Cable
S 8 Stop Lamp SW
S20 Stereo Jack Adapter

T 6 Tire Pressure Warning Reset SW
T 7 Transponder Key Amplifier
T 8 Transponder Key ECU
T 11 Tire Pressure Warning ECU

K 2 Knee Airbag Squib

U 1 Unlock Warning SW

N 2 Noise Filter (DOME)

Z 2 Option Connector (Front Fog Lamp SW)

O 1 Outer Mirror SW

Z 3 Option Connector (TVIP)

Z 4 Option Connector (IPOD Unit)

Z 5 Option Connector (Radio Receiver Assembly)

G ELECTRICAL WIRING ROUTING

Position of Parts in Body

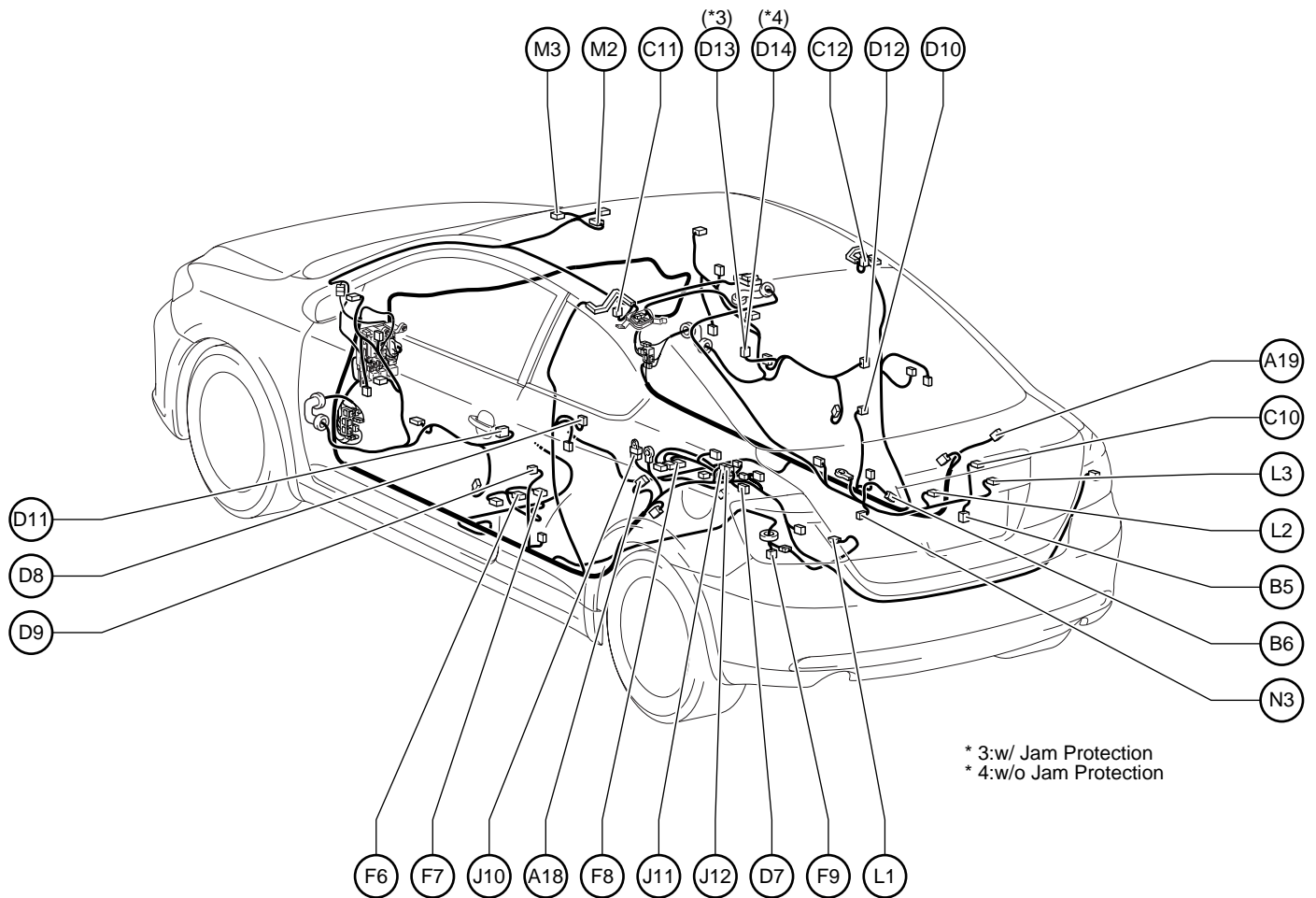

A 18 Airbag Sensor (Rear LH)
A 19 Airbag Sensor (Rear RH)

B 5 Back Door Lock Assembly
B 6 Back Door Opener SW

C 10 Center Stop Lamp
C 11 Curtain Shield Airbag Squib (LH)
C 12 Curtain Shield Airbag Squib (RH)

D 7 Diode (Room Lamp)
D 8 Door Control Receiver
D 9 Door Courtesy SW (Driver's Side)
D 10 Door Courtesy SW (Front Passenger's Side)
D 11 Door Lock Assembly (Driver's Side)
D 12 Door Lock Assembly (Front Passenger's Side)
D 13 Door Lock Control SW
D 14 Door Lock Control SW

F 6 Front Seat Inner Belt (Driver's Side)
F 7 Front Seat Inner Belt (Driver's Side)
F 8 Front Seat Inner Belt (Front Passenger's Side)
F 9 Fuel Suction Pump and Gage Assembly

J 10 Junction Connector
J 11 Junction Connector
J 12 Junction Connector

L 1 Canister Pump Module
L 2 License Plate Lamp (LH)
L 3 License Plate Lamp (RH)

M 2 Map Lamp
M 3 Map Lamp

N 3 Noise Filter (DEF and Stop)

* 3:w/ Jam Protection
* 4:w/o Jam Protection

Position of Parts in Body

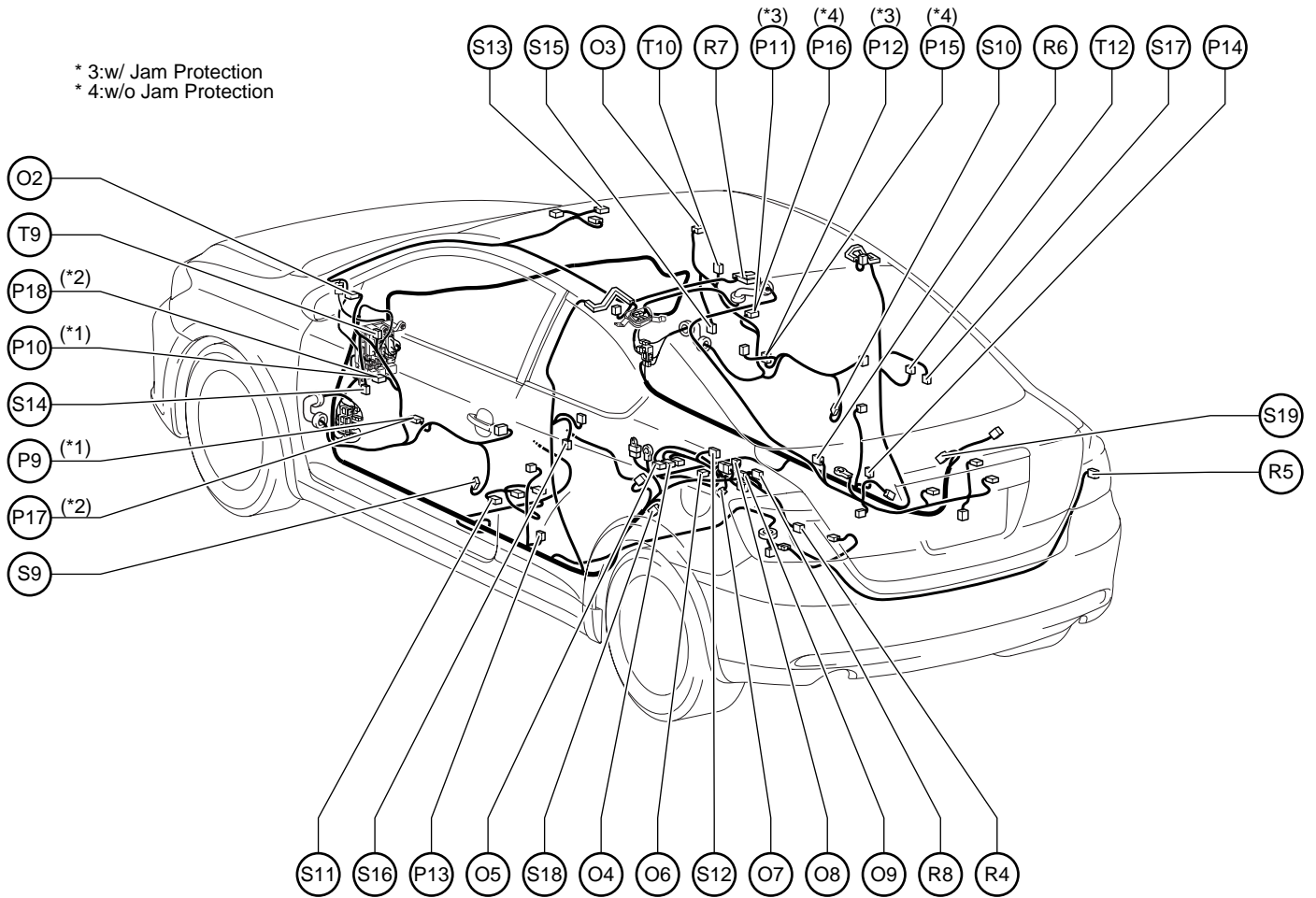

* 3:w/ Jam Protection
 * 4:w/o Jam Protection

- | | |
|--|--|
| O 2 Outer Rear View Mirror (LH) | R 4 Rear Combination Lamp (LH) |
| O 3 Outer Rear View Mirror (RH) | R 5 Rear Combination Lamp (RH) |
| O 4 Occupant Classification ECU | R 6 Rear Window Defogger |
| O 5 Occupant Classification ECU | R 7 Room Lamp (Center) |
| O 6 Occupant Classification Sensor Front LH | R 8 Room Lamp (Left Quarter) |
| O 7 Occupant Classification Sensor Rear LH | |
| O 8 Occupant Classification Sensor Front RH | S 9 Side Airbag Sensor (LH) |
| O 9 Occupant Classification Sensor Rear RH | S10 Side Airbag Sensor (RH) |
| | S11 Side Airbag Squib (LH) |
| P 9 Power Window Master SW | S12 Side Airbag Squib (RH) |
| P10 Power Window Regulator Motor (Front LH) | S13 Sliding Roof Control ECU |
| P11 Power Window Regulator Motor (Front RH) | S14 Speaker (Front Door LH) |
| P12 Power Window SW (Front Passenger's Side) | S15 Speaker (Front Door RH) |
| P13 Pretensioner (LH) | S16 Speaker (Rear LH) |
| P14 Pretensioner (RH) | S17 Speaker (Rear RH) |
| P15 Power Window SW (Front Passenger's Side) | S18 Speed Sensor (Rear LH) |
| P16 Power Window Regulator Motor (Front RH) | S19 Speed Sensor (Rear RH) |
| P17 Power Window Master SW | |
| P18 Power Window Regulator Motor (Front LH) | T 9 Tweeter (LH) |
| | T10 Tweeter (RH) |
| | T12 Tire Pressure Warning Antenna and Receiver |

G ELECTRICAL WIRING ROUTING

□ : Location of Connector Joining Wire Harness and Wire Harness

▽ : Location of Ground Points

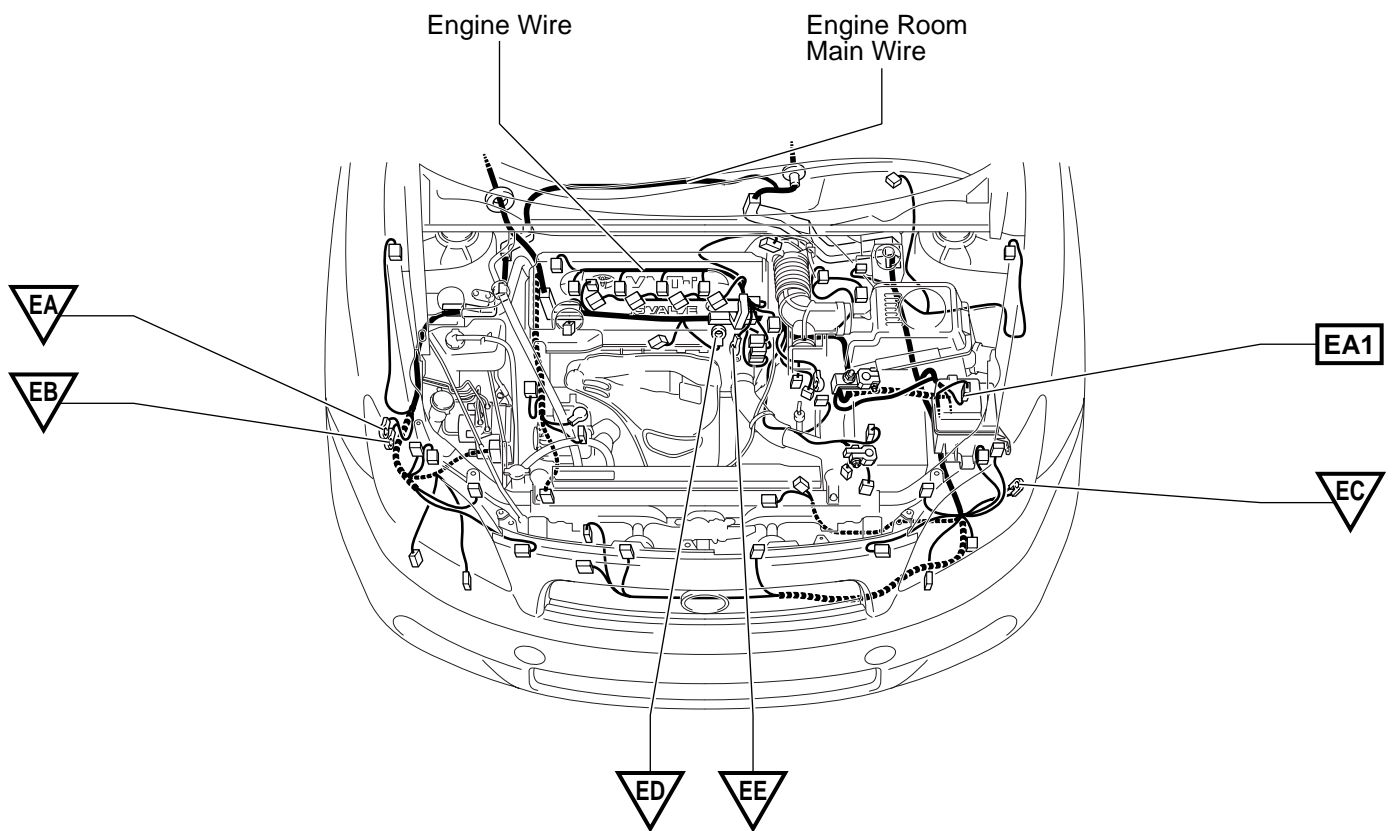

G ELECTRICAL WIRING ROUTING

□ : Location of Connector Joining Wire Harness and Wire Harness

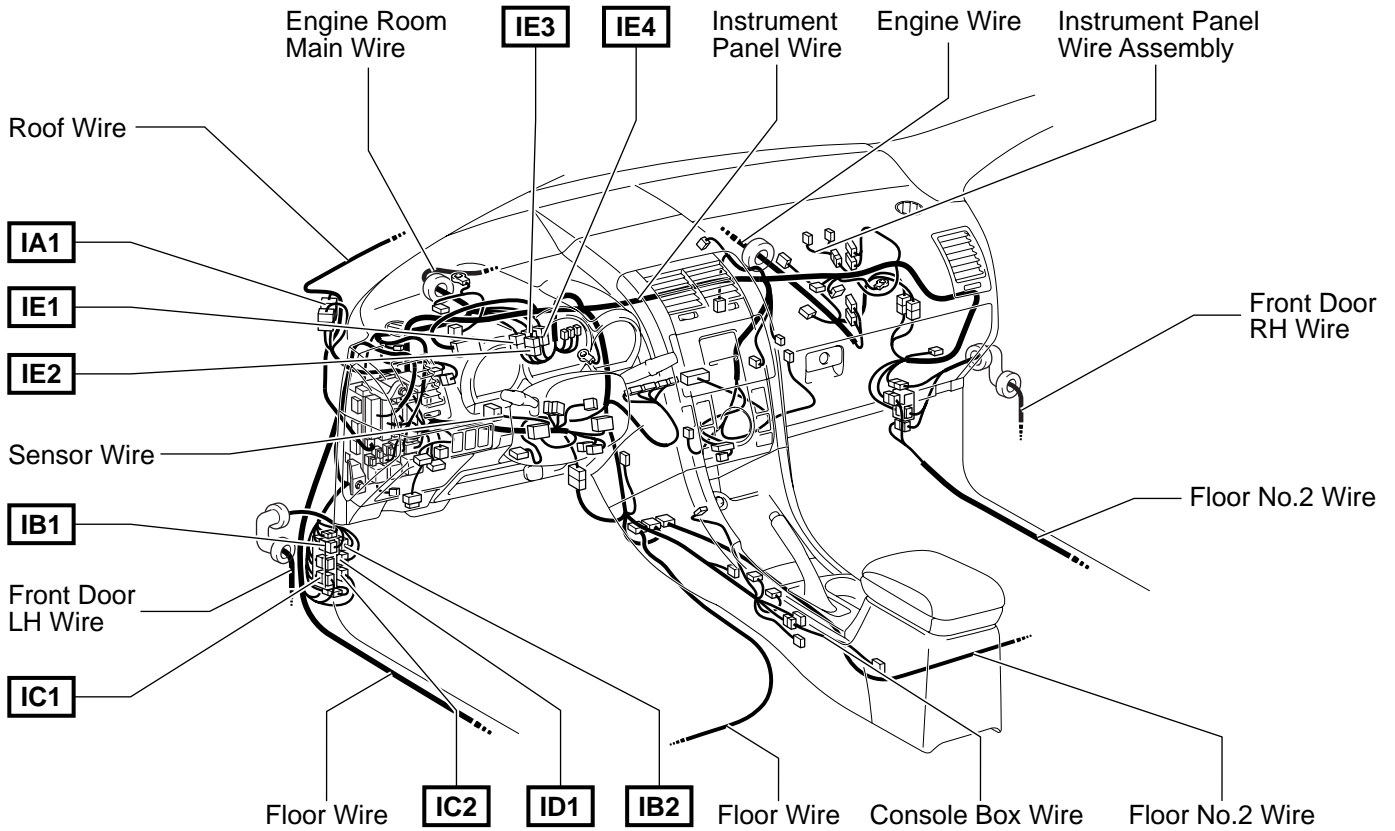

▽ : Location of Ground Points

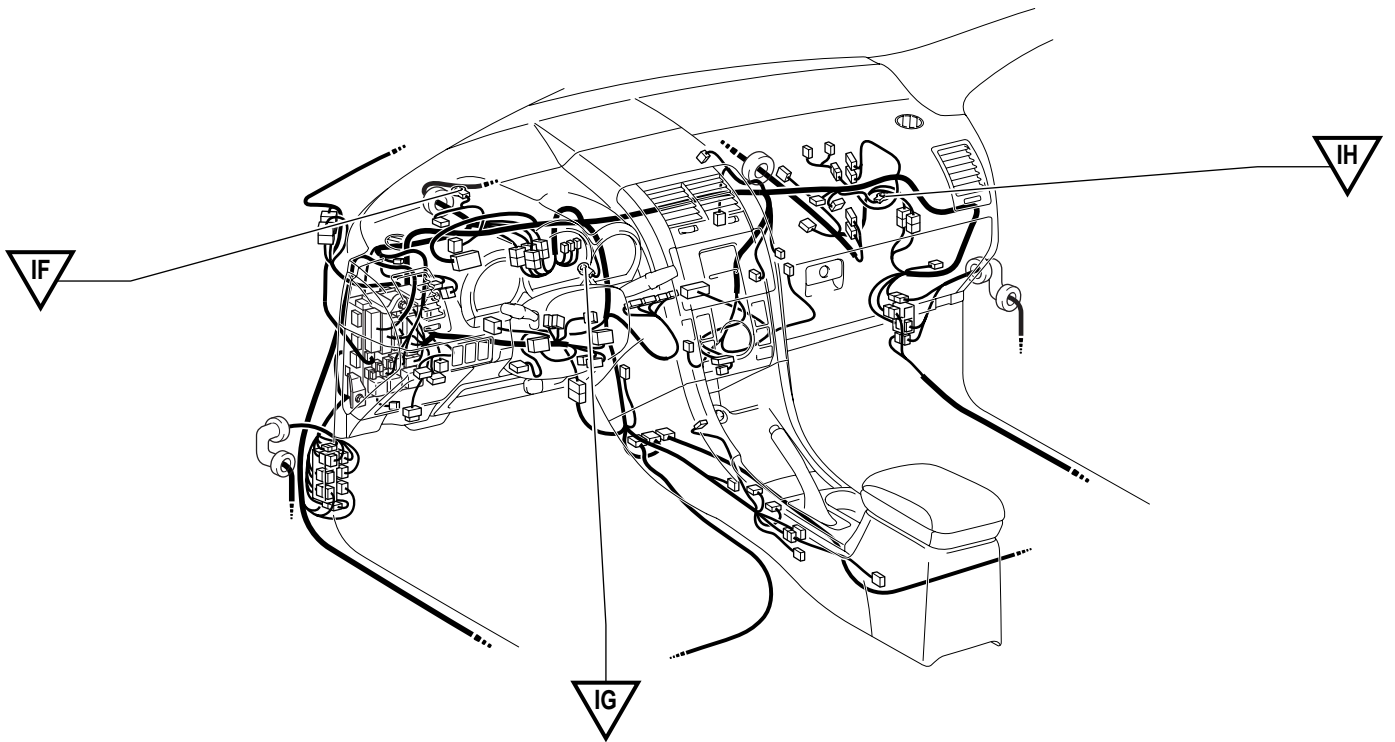

□ : Location of Connector Joining Wire Harness and Wire Harness

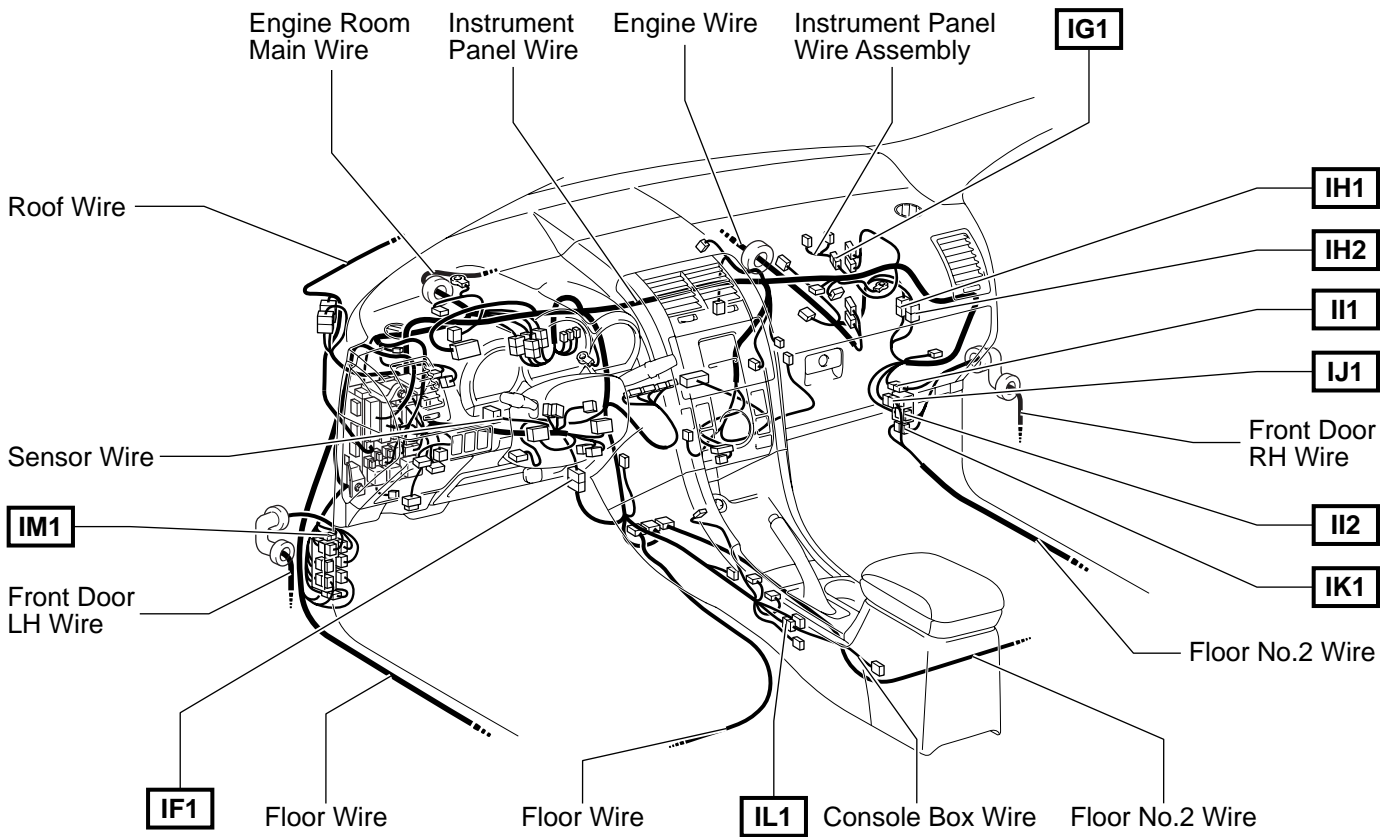

G ELECTRICAL WIRING ROUTING

□ : Location of Connector Joining Wire Harness and Wire Harness

▽ : Location of Ground Points

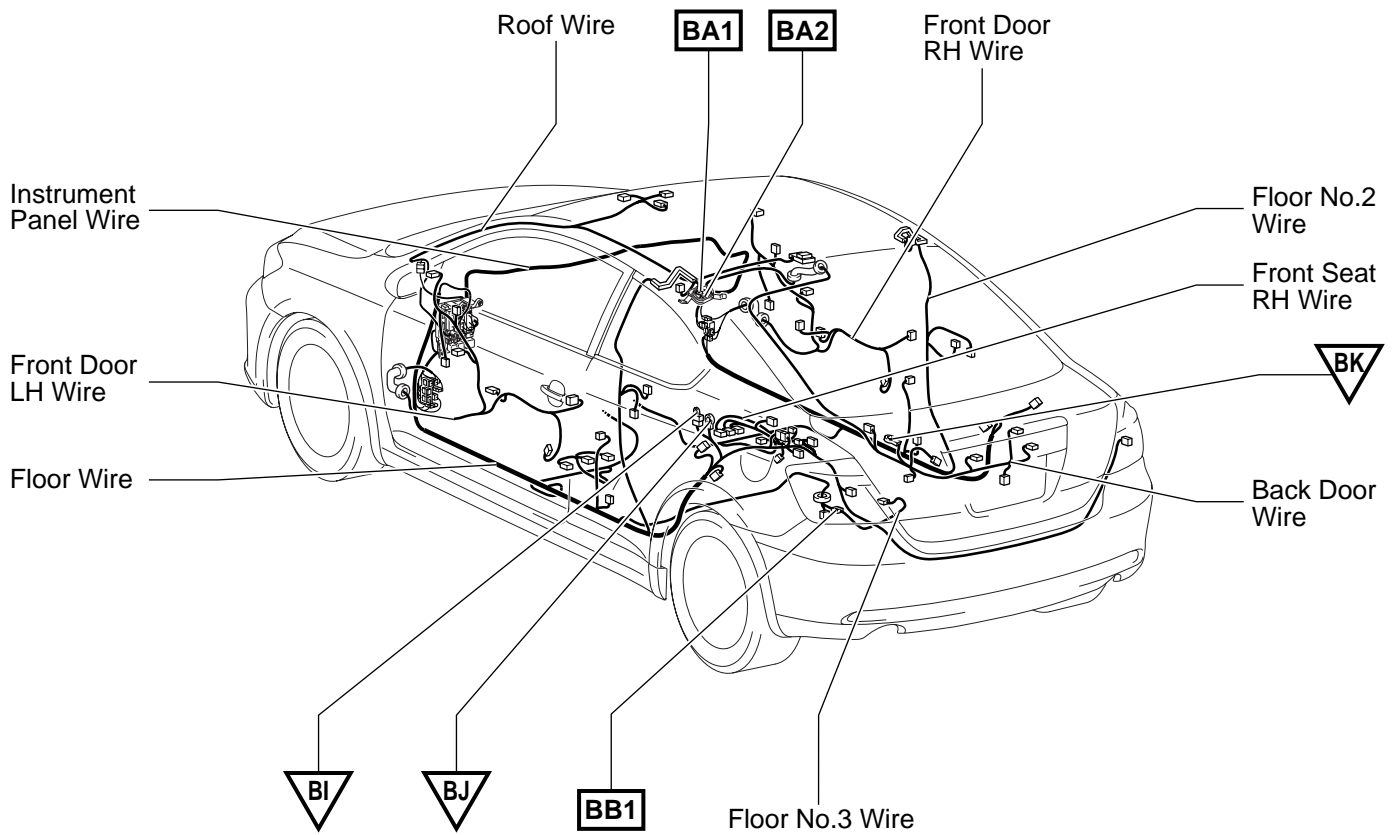

2007 tC ELECTRICAL WIRING DIAGRAM SYSTEM CIRCUITS

| | Page |
|--|------|
| ABS | 136 |
| Air Conditioning | 178 |
| Audio System | 166 |
| Back Door Opener | 114 |
| Back-Up Light | 90 |
| Charging | 54 |
| Cigarette Lighter | 154 |
| Combination Meter | 170 |
| Cruise Control | 130 |
| Door Lock Control | 104 |
| Electronically Controlled Transmission and A/T Indicator | 124 |
| Engine Control | 56 |
| Engine Immobiliser System | 66 |
| Front Wiper and Washer | 92 |
| Headlight | 72 |
| Horn | 152 |
| Ignition | 52 |
| Illumination | 82 |
| Interior Light | 78 |
| Key Reminder | 158 |
| Light Reminder | 160 |
| Multiplex Communication System (CAN) | 70 |
| Power Outlet | 156 |
| Power Source | 46 |
| Power Window (w/ Jam Protection) | 96 |
| Power Window (w/o Jam Protection) | 102 |
| Radiator Fan and Condenser Fan | 176 |
| Rear Window Defogger | 164 |
| Remote Control Mirror | 94 |
| Seat Belt Warning | 162 |
| Shift Lock | 122 |
| Sliding Roof | 118 |
| SRS | 145 |
| Starting | 50 |
| Stop Light | 88 |
| Taillight | 86 |
| Tire Pressure Warning System | 142 |
| Turn Signal and Hazard Warning Light | 74 |
| Wireless Door Lock Control | 108 |

Power Source

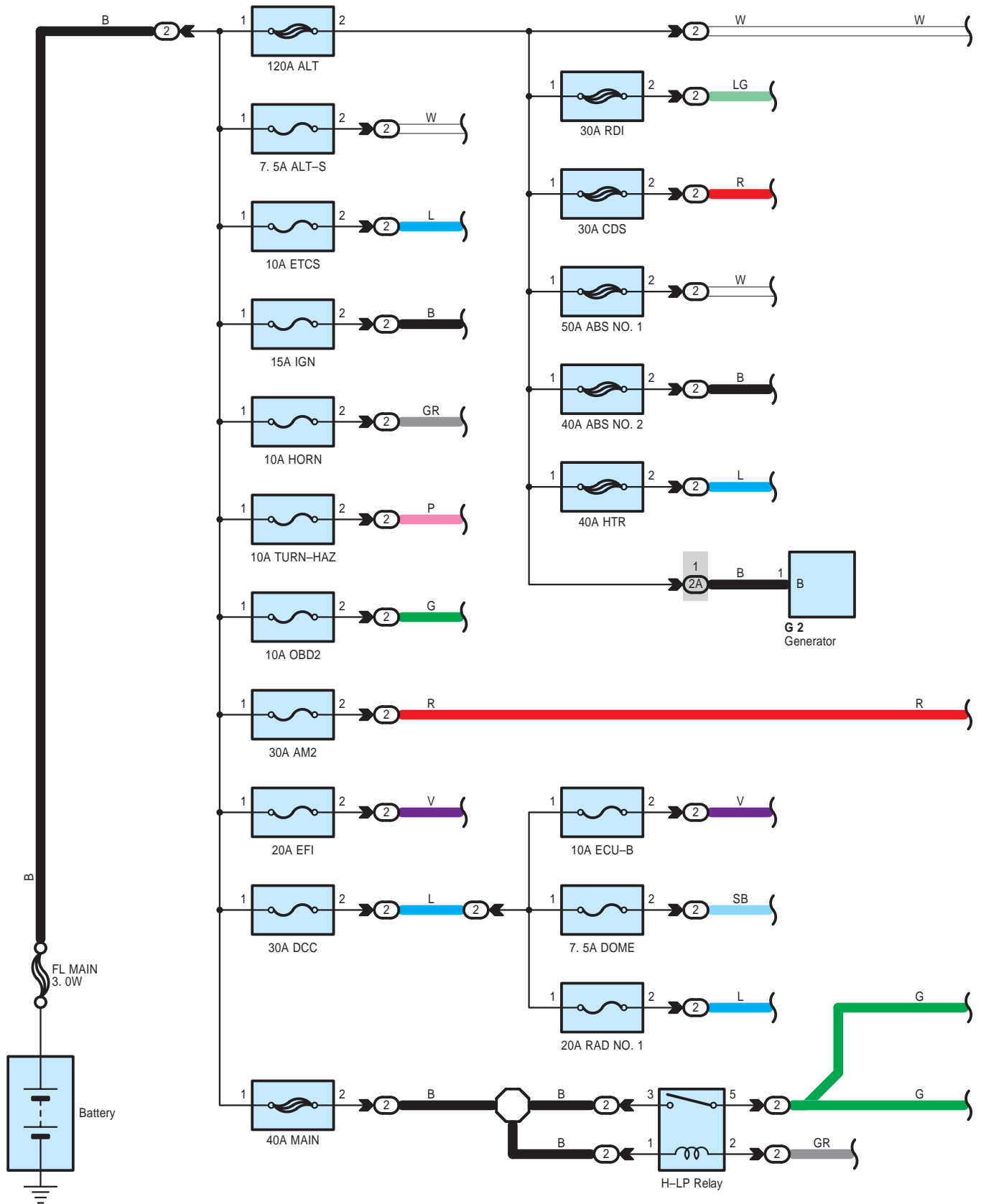

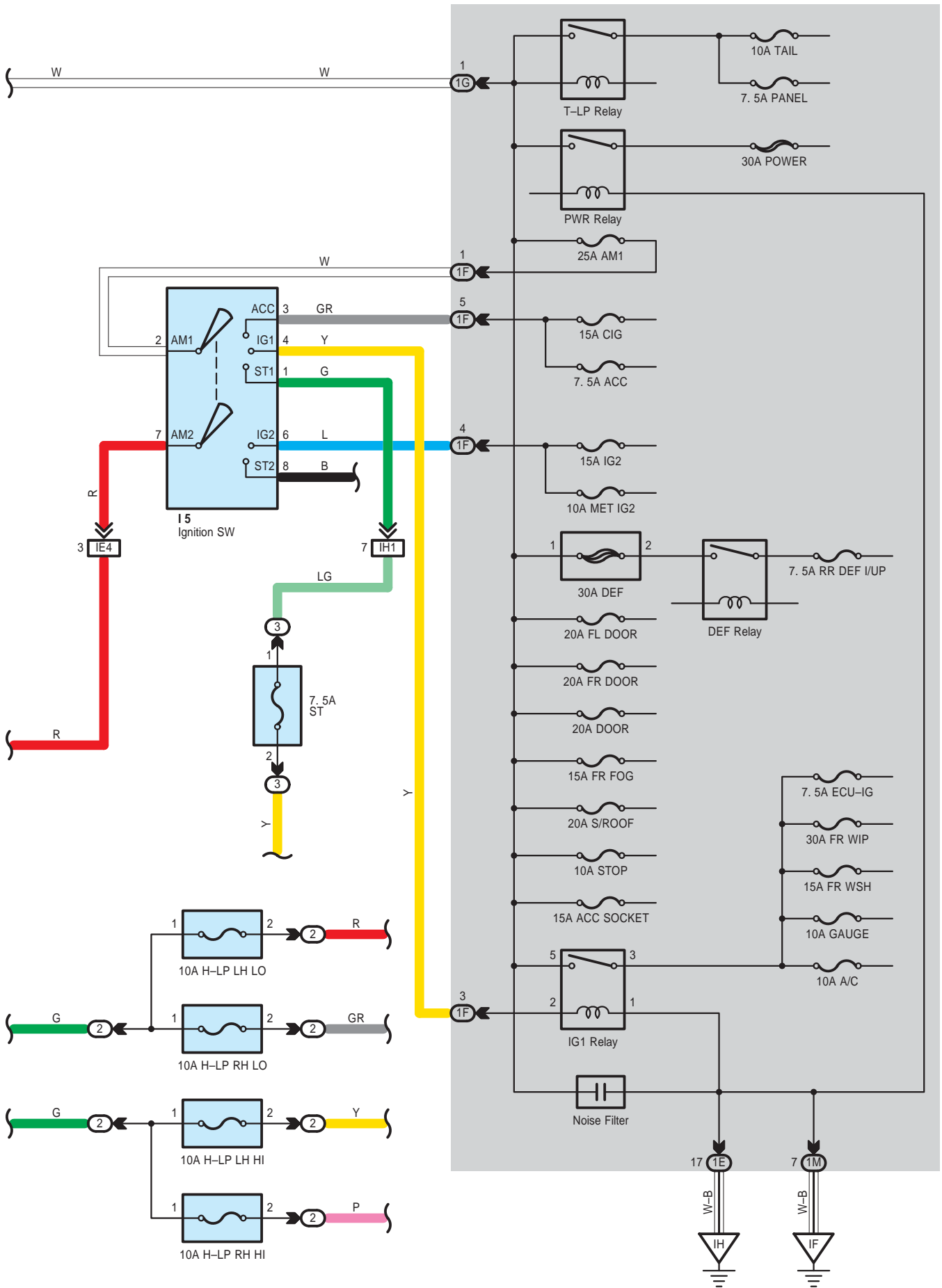

SCION tC (EM0300U)

Power Source

: Parts Location

| Code | See Page | Code | See Page | Code | See Page |
|------|----------|------|----------|------|----------|
| G2 | 34 | I5 | 37 | | |

: Relay Blocks

| Code | See Page | Relay Blocks (Relay Block Location) |
|------|----------|--|
| 2 | 22 | Engine Room R/B (Engine Compartment Left) |
| 3 | 23 | Engine Room R/B No.2 (Inside of the Engine Room R/B Box) |

: Junction Block and Wire Harness Connector

| Code | See Page | Junction Block and Wire Harness (Connector Location) |
|------|----------|---|
| 1E | 24 | Instrument Panel Wire and Instrument Panel J/B (Lower Finish Panel) |
| 1F | | |
| 1G | 24 | Engine Room Main Wire and Instrument Panel J/B (Lower Finish Panel) |
| 1M | 25 | Instrument Panel Wire and Instrument Panel J/B (Lower Finish Panel) |
| 2A | 22 | Engine Wire and Engine Room J/B (Engine Compartment Left) |

: Connector Joining Wire Harness and Wire Harness

| Code | See Page | Joining Wire Harness and Wire Harness (Connector Location) |
|------|----------|---|
| IE4 | 42 | Engine Room Main Wire and Instrument Panel Wire (Behind of the Combination Meter) |
| IH1 | 43 | Engine Wire and Instrument Panel Wire (Cowl Side Panel RH) |

: Ground Points

| Code | See Page | Ground Points Location |
|------|----------|------------------------|
| IF | 42 | Cowl Brace LH |
| IH | 42 | Cowl Brace RH |

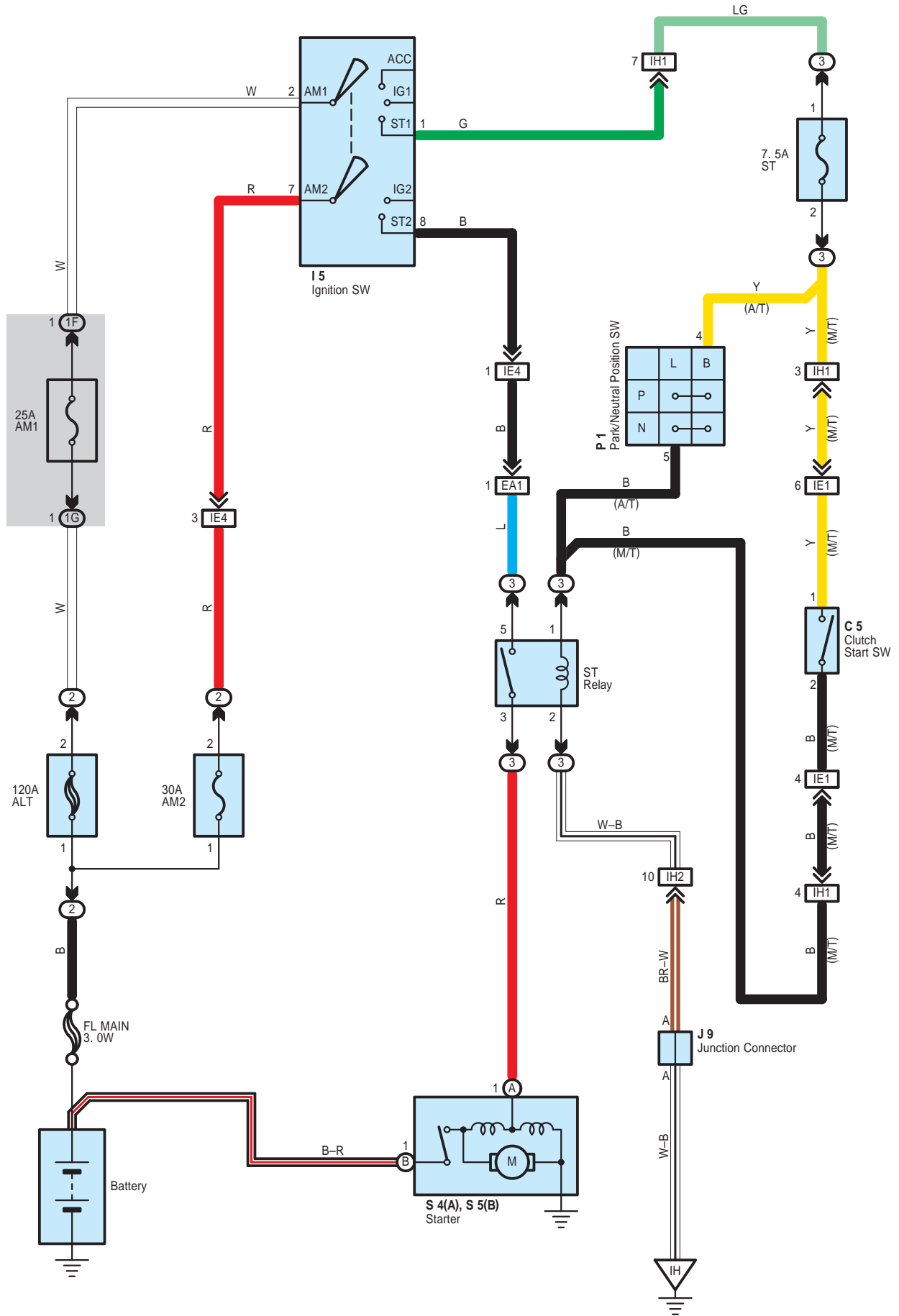

 : **Parts Location**

| Code | See Page | Code | See Page | Code | See Page |
|------|----------|------|----------|------|----------|
| C5 | 36 | J9 | 37 | S4 | A 35 |
| I5 | 37 | P1 | 35 | S5 | B 35 |

 : **Relay Blocks**

| Code | See Page | Relay Blocks (Relay Block Location) |
|------|----------|--|
| 2 | 22 | Engine Room R/B (Engine Compartment Left) |
| 3 | 23 | Engine Room R/B No.2 (Inside of the Engine Room R/B Box) |

 : **Junction Block and Wire Harness Connector**

| Code | See Page | Junction Block and Wire Harness (Connector Location) |
|------|----------|---|
| 1F | 24 | Instrument Panel Wire and Instrument Panel J/B (Lower Finish Panel) |
| 1G | 24 | Engine Room Main Wire and Instrument Panel J/B (Lower Finish Panel) |

 : **Connector Joining Wire Harness and Wire Harness**

| Code | See Page | Joining Wire Harness and Wire Harness (Connector Location) |
|------|----------|---|
| EA1 | 40 | Engine Wire and Engine Room Main Wire (Inside of the Engine Room R/B Box) |
| IE1 | 42 | Engine Room Main Wire and Instrument Panel Wire (Behind of the Combination Meter) |
| IE4 | | |
| IH1 | 43 | Engine Wire and Instrument Panel Wire (Cowl Side Panel RH) |
| IH2 | | |

 : **Ground Points**

| Code | See Page | Ground Points Location |
|------|----------|------------------------|
| IH | 42 | Cowl Brace RH |

Ignition

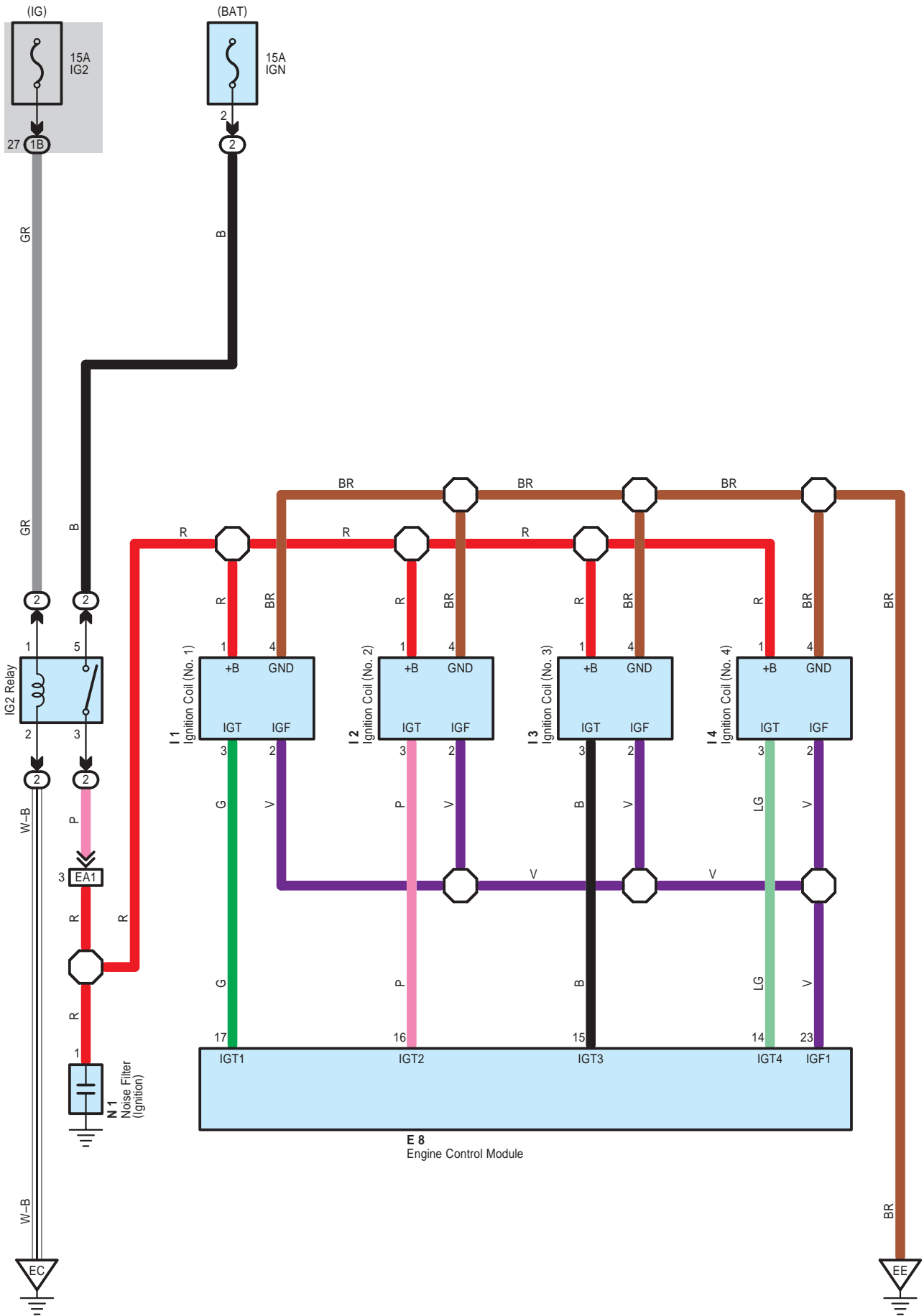

 : **Parts Location**

| Code | See Page | Code | See Page | Code | See Page |
|------|----------|------|----------|------|----------|
| E8 | 36 | I2 | 35 | I4 | 35 |
| I1 | 35 | I3 | 35 | N1 | 35 |

 : **Relay Blocks**

| Code | See Page | Relay Blocks (Relay Block Location) |
|------|----------|---|
| 2 | 22 | Engine Room R/B (Engine Compartment Left) |

 : **Junction Block and Wire Harness Connector**

| Code | See Page | Junction Block and Wire Harness (Connector Location) |
|------|----------|---|
| 1B | 24 | Engine Room Main Wire and Instrument Panel J/B (Lower Finish Panel) |

 : **Connector Joining Wire Harness and Wire Harness**

| Code | See Page | Joining Wire Harness and Wire Harness (Connector Location) |
|------|----------|---|
| EA1 | 40 | Engine Wire and Engine Room Main Wire (Inside of the Engine Room R/B Box) |

 : **Ground Points**

| Code | See Page | Ground Points Location |
|------|----------|--------------------------------|
| EC | 40 | Front Left Fender |
| EE | 40 | Left Side of the Cylinder Head |

Charging

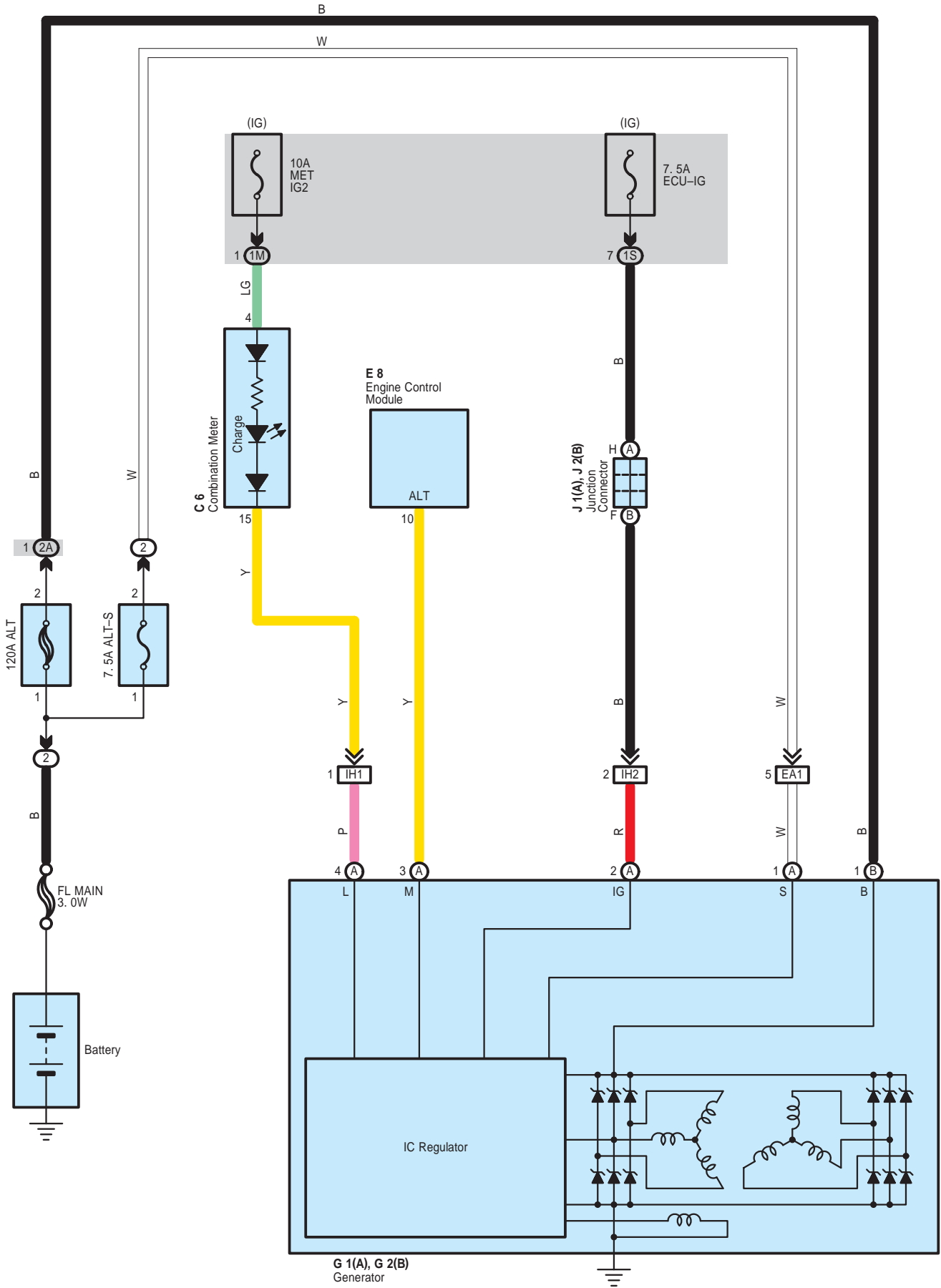

: **Parts Location**

| Code | See Page | Code | See Page | Code | See Page |
|------|----------|------|----------|------|----------|
| C6 | 36 | G1 | A 34 | J1 | A 37 |
| E8 | 36 | G2 | B 34 | J2 | B 37 |

: **Relay Blocks**

| Code | See Page | Relay Blocks (Relay Block Location) |
|------|----------|---|
| 2 | 22 | Engine Room R/B (Engine Compartment Left) |

: **Junction Block and Wire Harness Connector**

| Code | See Page | Junction Block and Wire Harness (Connector Location) |
|------|----------|---|
| 1M | 25 | Instrument Panel Wire and Instrument Panel J/B (Lower Finish Panel) |
| 1S | | |
| 2A | 22 | Engine Wire and Engine Room J/B (Engine Compartment Left) |

: **Connector Joining Wire Harness and Wire Harness**

| Code | See Page | Joining Wire Harness and Wire Harness (Connector Location) |
|------|----------|---|
| EA1 | 40 | Engine Wire and Engine Room Main Wire (Inside of the Engine Room R/B Box) |
| IH1 | 43 | Engine Wire and Instrument Panel Wire (Cowl Side Panel RH) |
| IH2 | | |

Engine Control

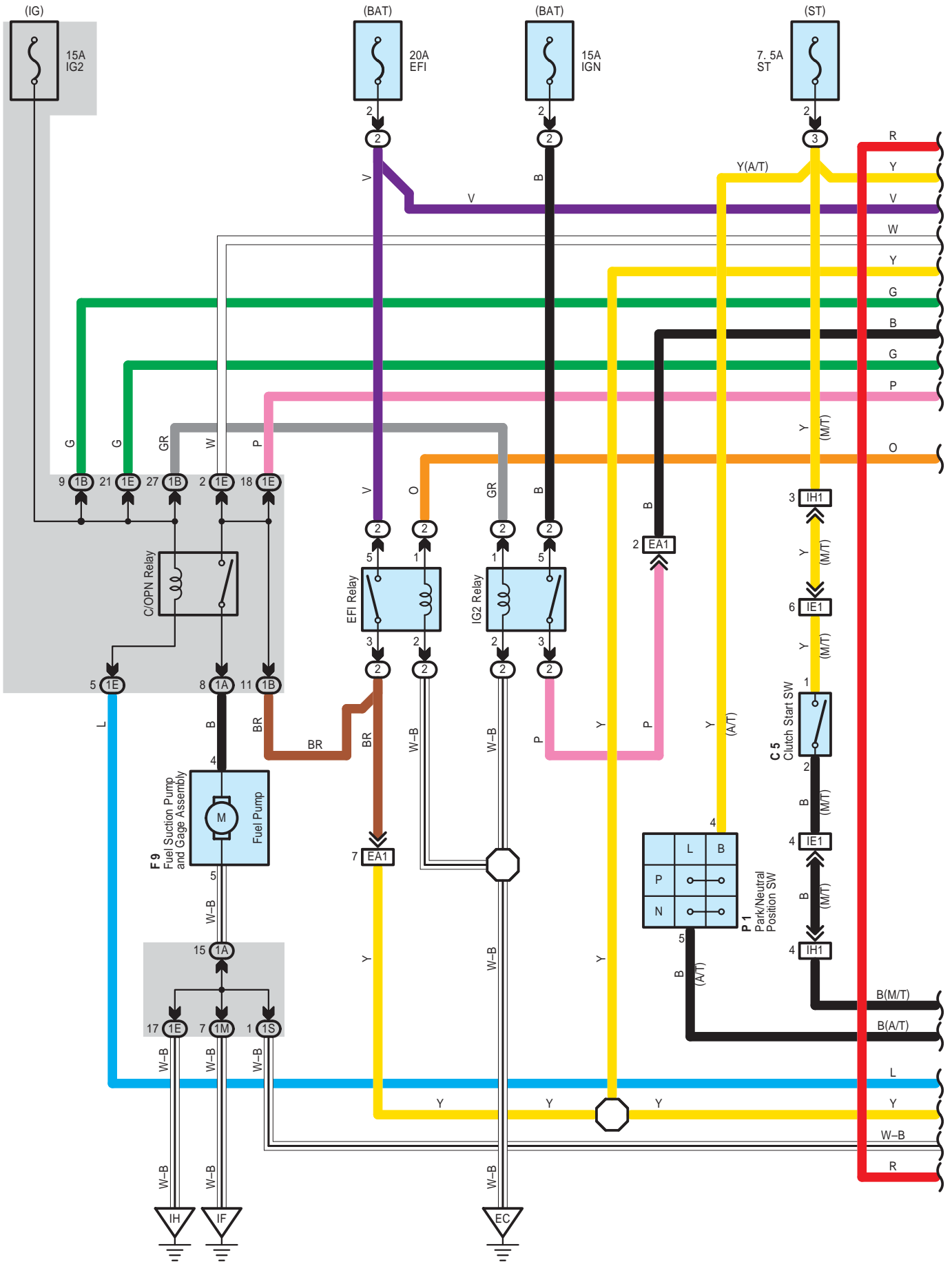

- * 1 : Shielded
- * 2 : w/ Engine Immobiliser System

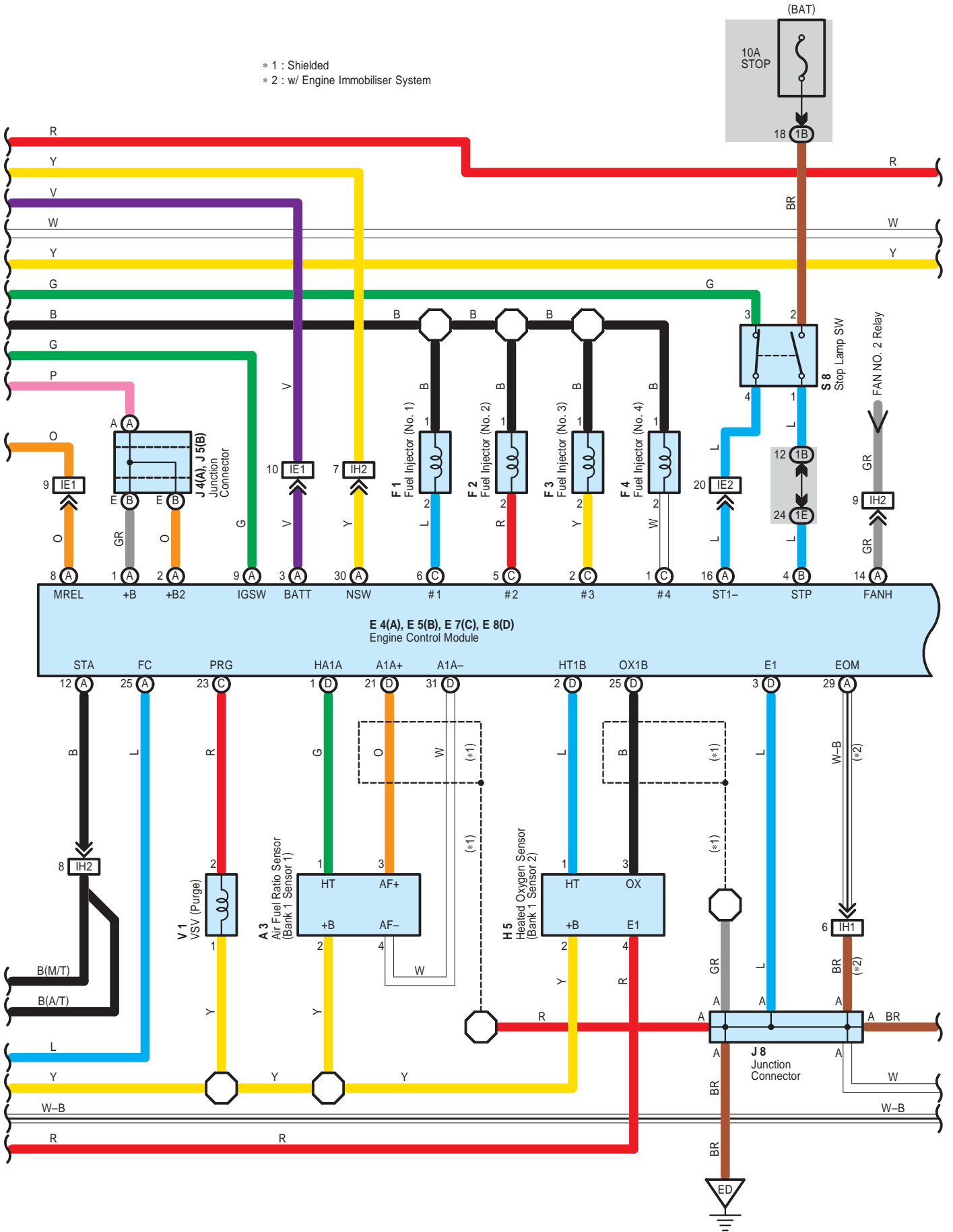

Engine Control

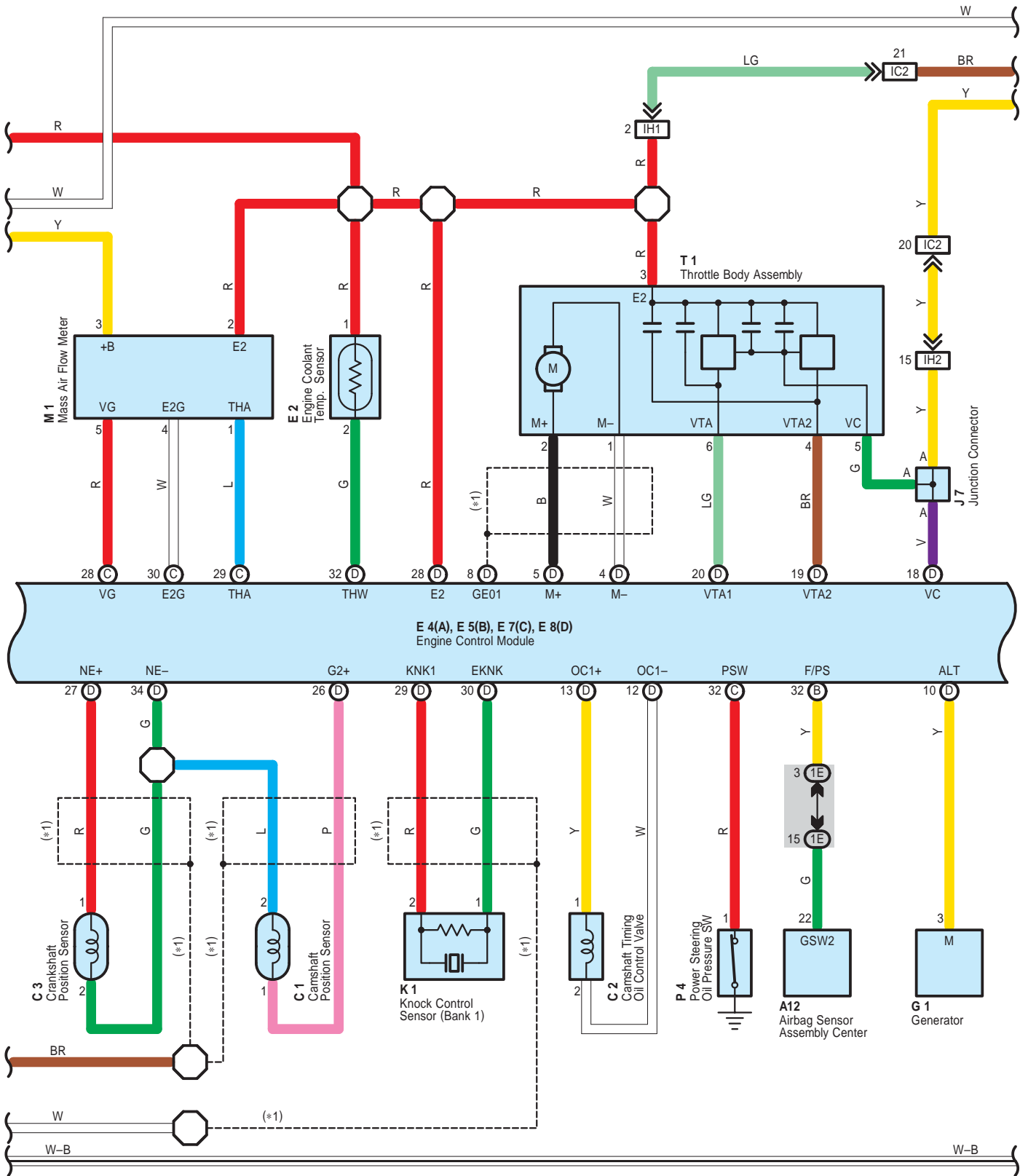

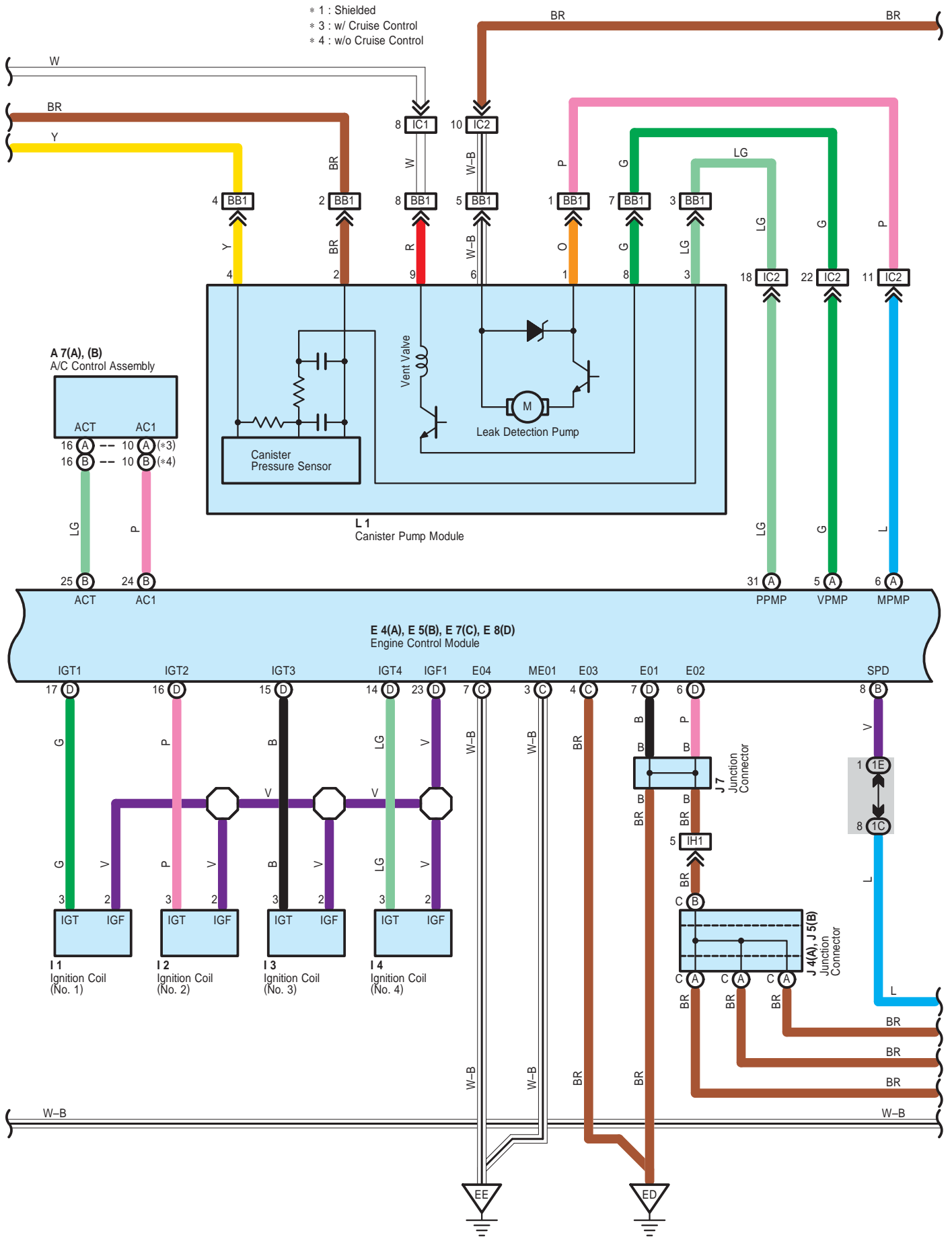

Engine Control

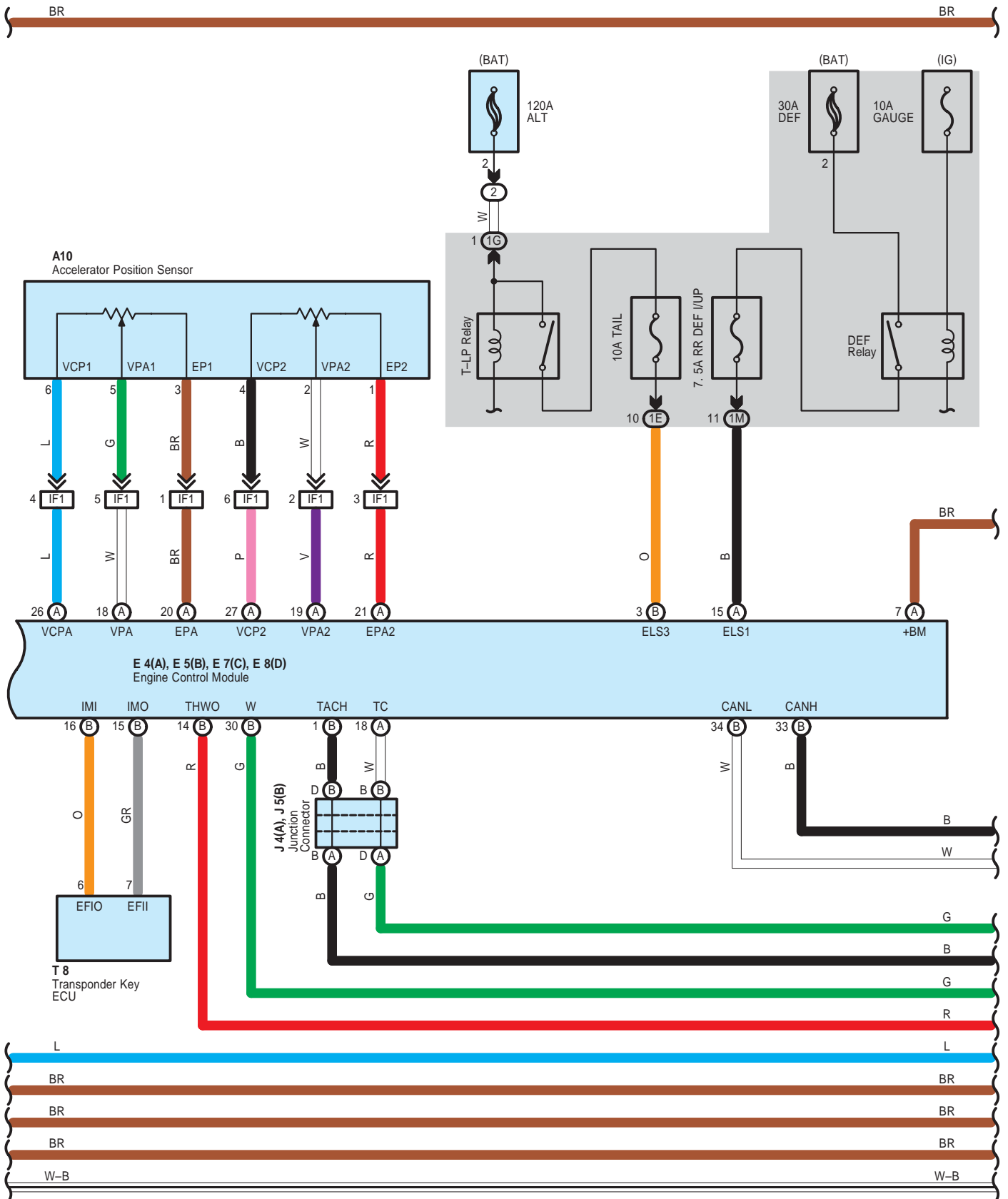

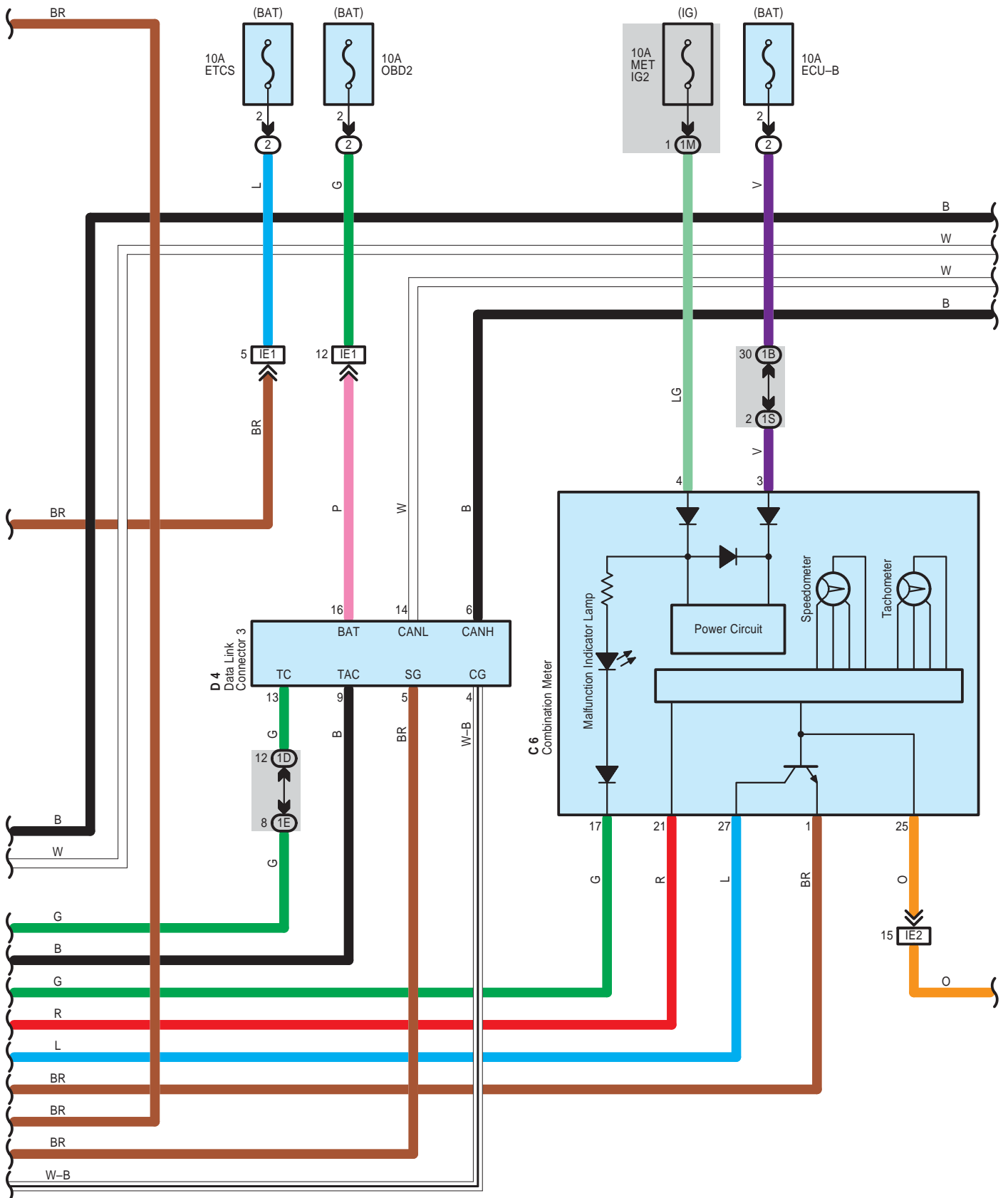

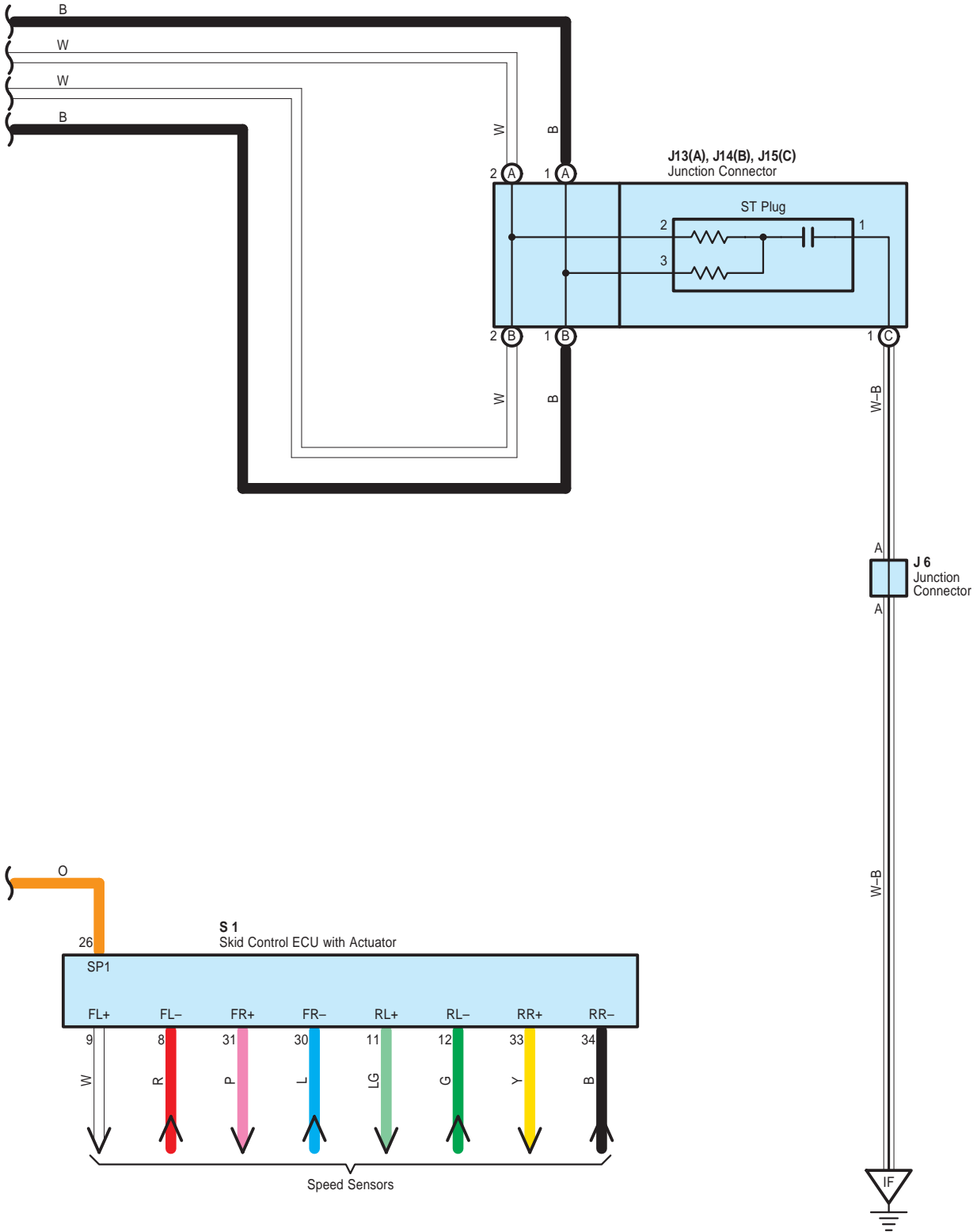

System Outline

The engine control system utilizes a microcomputer and maintains overall control of the engine, transaxle etc. An outline of the engine control is given here.

1. Input Signals

- (1) Engine coolant temp. signal circuit
The engine coolant temp. sensor detects the engine coolant temp. and has a built-in thermistor with a resistance, which varies according to the engine coolant temp.. The engine coolant temp. which is input into TERMINAL THW of the engine control module as a control signal.
- (2) Intake air temp. signal circuit
The intake air temp. sensor is installed in the mass air flow meter and detects the intake air temp. which is input as a control signal to TERMINAL THA of the engine control module.
- (3) Oxygen density signal circuit
The oxygen density in the exhaust emission is detected by the heated oxygen sensor and input as a control signal to TERMINAL OX1B of the engine control module.
- (4) RPM signal circuit
Camshaft position and crankshaft position are detected by the camshaft position sensor and crankshaft position sensor. Camshaft position is input as a control signal to TERMINAL G2+ of the engine control module, and engine RPM is input into TERMINAL NE+.
- (5) Throttle position signal circuit
The throttle body assembly detects the throttle valve opening angle as a control signal, which is input into TERMINALS VTA1 and VTA2 of the engine control module.
- (6) Vehicle speed circuit
The vehicle speed sensor detects the vehicle speed and inputs a control signal to TERMINAL SPD of the engine control module.
- (7) Battery signal circuit
Voltage is constantly applied to TERMINAL BATT of the engine control module. With the ignition SW turned on, the voltage for engine control module start-up power supply is applied to TERMINAL +B of the engine control module via the EFI relay.
- (8) Stop lamp SW signal circuit
The stop lamp SW is used to detect whether the vehicle is braking or not and the signal is input into TERMINAL STP of the engine control module as a control signal.
- (9) Starter signal circuit
To confirm whether the engine is cranking, the voltage is applied to the starter motor during cranking is detected and the signal is input into TERMINAL STA of the engine control module as a control signal.
- (10) Engine knock signal circuit
Engine knocking is detected by knock control sensor and the signal is input into TERMINAL KNK1 as a control signal.
- (11) Air fuel ratio signal system
The air fuel ratio is detected by air fuel ratio sensor and input as a control signal into TERMINAL A1A+ of the engine control module.

Engine Control

2. Control System

* SFI system

The SFI system monitors the engine condition through the signals input from each sensor to the engine control module. And the control signal is output to TERMINALS #1, #2, #3 and #4 of the engine control module to operate the fuel injector (Inject the fuel). The SFI system controls the fuel injection operation by the engine control module in response to the driving conditions.

* ESA system

The ESA system monitors the engine condition through the signals input to the engine control module from each sensor. The best ignition timing is decided according to this data and the memorized data in the engine control module and the control signal is output to TERMINALS IGT1, IGT2, IGT3, IGT4. This signal controls the igniter (Ignition coil) to provide the best ignition timing for the driving conditions.

* Heated oxygen sensor heater control system

The heated oxygen sensor heater control system turns the heater on when the intake air volume is low (Temp. of exhaust emissions is low), and warms up the heated oxygen sensor to improve detection performance of the sensor. The engine control module evaluates the signals from each sensor, and outputs current to TERMINAL HT1B to control the heater.

3. Diagnosis System

With the diagnosis system, when there is a malfunction in the engine control module signal system, the malfunctioning system is recorded in the memory. The malfunctioning system can be found by reading the code displayed by the malfunction indicator lamp.

4. Fail-Safe System

When a malfunction has occurred in any system, if there is a possibility of engine trouble being caused by continued control based on the signals from that system, the fail-safe system either controls the system by using data (Standard values) recorded in the engine control module memory or else stops the engine.

○ : Parts Location

| Code | See Page | Code | See Page | Code | See Page |
|--------|----------|--------|----------|---------|----------|
| A3 | 34 | E8 D | 36 | J7 | 37 |
| A7 | A | F1 | 34 | J8 | 37 |
| | B | F2 | 34 | J13 A | 32, 37 |
| A10 | 36 | F3 | 34 | J14 B | 32, 37 |
| A12 | 36 | F4 | 34 | J15 C | 32, 37 |
| C1 | 34 | F9 | 38 | K1 | 35 |
| C2 | 34 | G1 | 34 | L1 | 38 |
| C3 | 34 | H5 | 34 | M1 | 35 |
| C5 | 36 | I1 | 35 | P1 | 35 |
| C6 | 36 | I2 | 35 | P4 | 35 |
| D4 | 36 | I3 | 35 | S1 | 35 |
| E2 | 34 | I4 | 35 | S8 | 37 |
| E4 A | 36 | J4 A | 37 | T1 | 35 |
| E5 B | 36 | J5 B | 37 | T8 | 37 |
| E7 C | 36 | J6 | 37 | V1 | 35 |

○ : Relay Blocks

| Code | See Page | Relay Blocks (Relay Block Location) |
|------|----------|--|
| 2 | 22 | Engine Room R/B (Engine Compartment Left) |
| 3 | 23 | Engine Room R/B No.2 (Inside of the Engine Room R/B Box) |

 : **Junction Block and Wire Harness Connector**

| Code | See Page | Junction Block and Wire Harness (Connector Location) |
|------|----------|---|
| 1A | 24 | Floor Wire and Instrument Panel J/B (Lower Finish Panel) |
| 1B | 24 | Engine Room Main Wire and Instrument Panel J/B (Lower Finish Panel) |
| 1C | 24 | Instrument Panel Wire and Instrument Panel J/B (Lower Finish Panel) |
| 1D | | |
| 1E | | |
| 1G | 24 | Engine Room Main Wire and Instrument Panel J/B (Lower Finish Panel) |
| 1M | 25 | Instrument Panel Wire and Instrument Panel J/B (Lower Finish Panel) |
| 1S | | |

 : **Connector Joining Wire Harness and Wire Harness**

| Code | See Page | Joining Wire Harness and Wire Harness (Connector Location) |
|------|----------|---|
| EA1 | 40 | Engine Wire and Engine Room Main Wire (Inside of the Engine Room R/B Box) |
| IC1 | 42 | Floor Wire and Instrument Panel Wire (Left Kick Panel) |
| IC2 | | |
| IE1 | 42 | Engine Room Main Wire and Instrument Panel Wire (Behind of the Combination Meter) |
| IE2 | | |
| IF1 | 43 | Instrument Panel Wire and Sensor Wire (Instrument Panel Brace LH) |
| IH1 | 43 | Engine Wire and Instrument Panel Wire (Cowl Side Panel RH) |
| IH2 | | |
| BB1 | 44 | Floor Wire and Floor No.3 Wire (Center Floor Pan Center) |

 : **Ground Points**

| Code | See Page | Ground Points Location |
|------|----------|--------------------------------------|
| EC | 40 | Front Left Fender |
| ED | 40 | Front Left Side of the Cylinder Head |
| EE | 40 | Left Side of the Cylinder Head |
| IF | 42 | Cowl Brace LH |
| IH | 42 | Cowl Brace RH |

Engine Immobiliser System

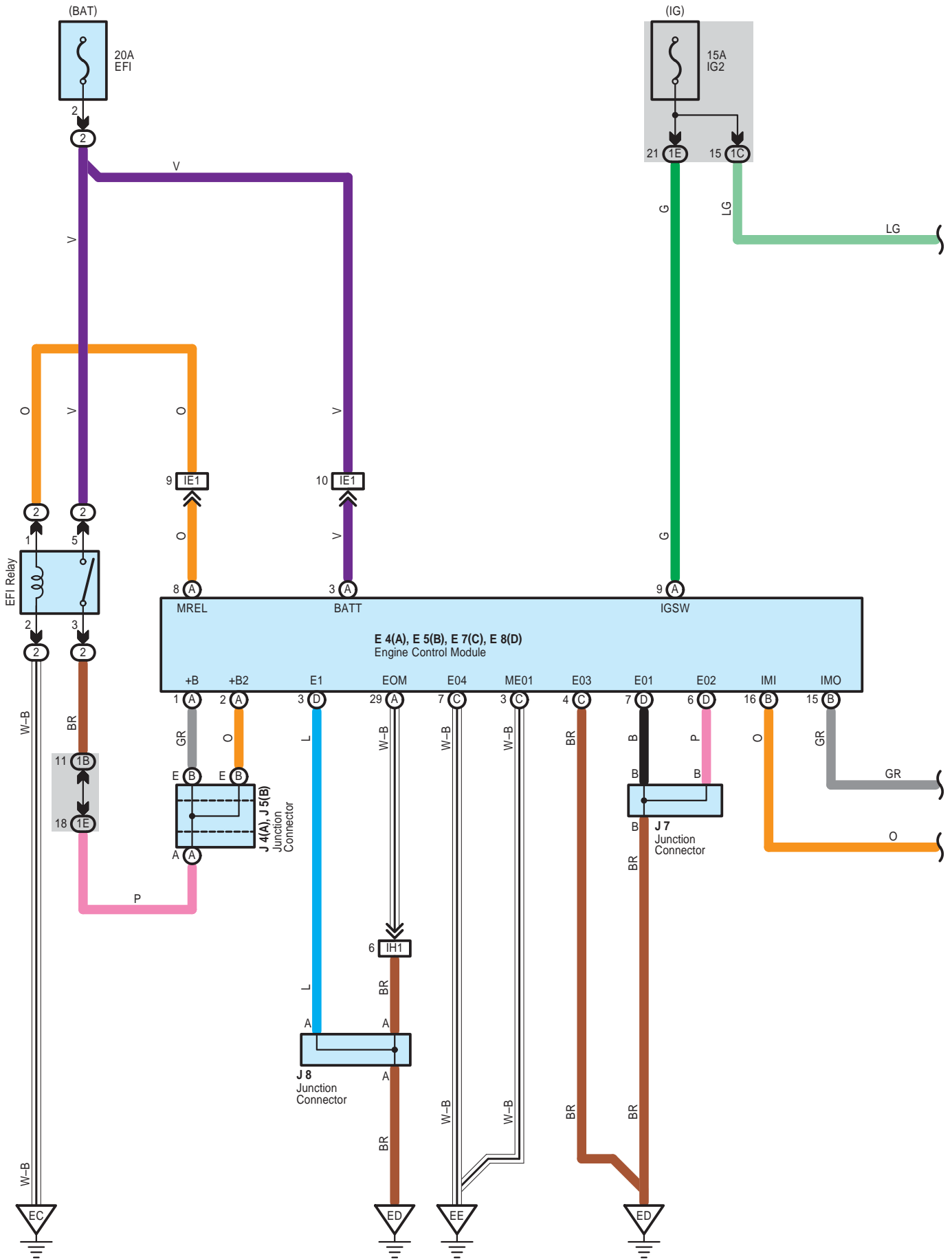

* 1 : w/ Cruise Control
 * 2 : w/o Cruise Control

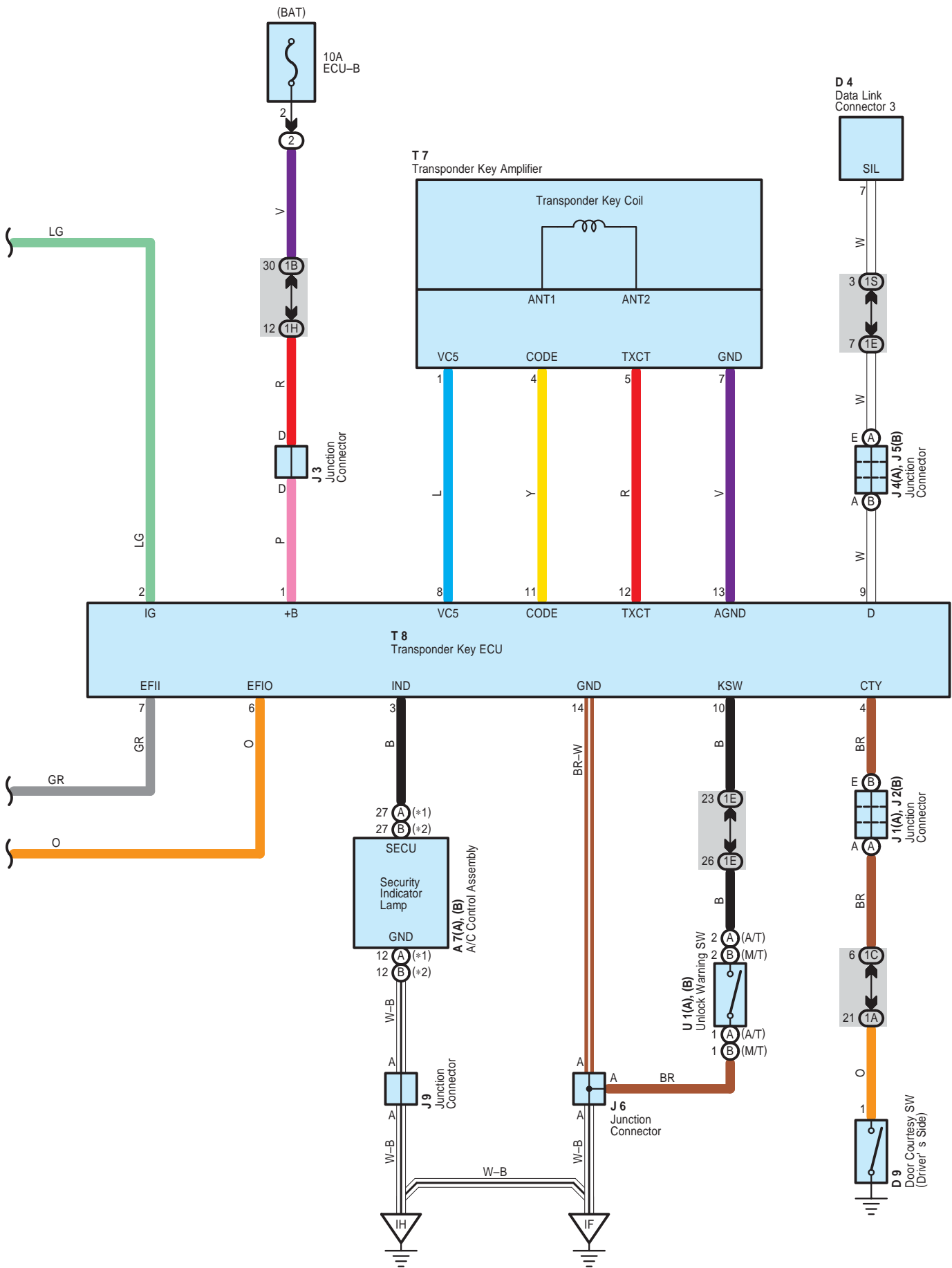

Engine Immobiliser System

: Parts Location

| Code | | See Page | Code | | See Page | Code | | See Page |
|------|---|----------|------|---|----------|------|----|----------|
| A7 | A | 36 | E8 | D | 36 | J7 | 37 | |
| | B | 36 | J1 | A | 37 | J8 | 37 | |
| D4 | | 36 | J2 | B | 37 | J9 | 37 | |
| D9 | | 38 | J3 | | 37 | T7 | 37 | |
| E4 | A | 36 | J4 | A | 37 | T8 | | |
| E5 | B | 36 | J5 | B | 37 | U1 | A | 37 |
| E7 | C | 36 | J6 | | 37 | | B | 37 |

: Relay Blocks

| Code | See Page | Relay Blocks (Relay Block Location) |
|------|----------|---|
| 2 | 22 | Engine Room R/B (Engine Compartment Left) |

: Junction Block and Wire Harness Connector

| Code | See Page | Junction Block and Wire Harness (Connector Location) |
|------|----------|---|
| 1A | 24 | Floor Wire and Instrument Panel J/B (Lower Finish Panel) |
| 1B | 24 | Engine Room Main Wire and Instrument Panel J/B (Lower Finish Panel) |
| 1C | 24 | Instrument Panel Wire and Instrument Panel J/B (Lower Finish Panel) |
| 1E | | |
| 1H | | |
| 1S | | |

: Connector Joining Wire Harness and Wire Harness

| Code | See Page | Joining Wire Harness and Wire Harness (Connector Location) |
|------|----------|---|
| IE1 | 42 | Engine Room Main Wire and Instrument Panel Wire (Behind of the Combination Meter) |
| IH1 | 43 | Engine Wire and Instrument Panel Wire (Cowl Side Panel RH) |

: Ground Points

| Code | See Page | Ground Points Location |
|------|----------|--------------------------------------|
| EC | 40 | Front Left Fender |
| ED | 40 | Front Left Side of the Cylinder Head |
| EE | 40 | Left Side of the Cylinder Head |
| IF | 42 | Cowl Brace LH |
| IH | 42 | Cowl Brace RH |

Multiplex Communication System – CAN

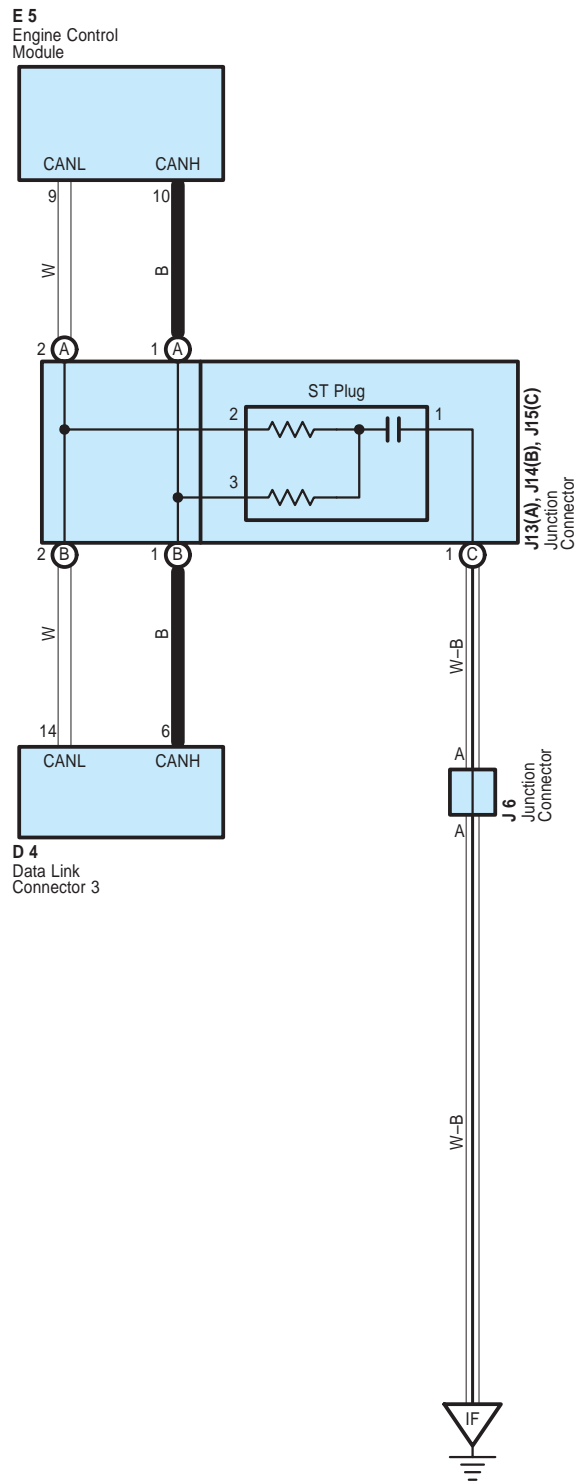

System Outline

Multiplex communication system (CAN) uses a serial communication protocol and communicates with a differential voltage. In this network system, TERMINALS CANH and CANL are used for communication between the ECUs and sensors, and excellent data communication speed and communication error detecting facility are provided.

○ : Parts Location

| Code | See Page | Code | See Page | Code | See Page |
|------|----------|------|----------|------|----------|
| D4 | 36 | J6 | 37 | J14 | B 32, 37 |
| E5 | 36 | J13 | A 32, 37 | J15 | C 32, 37 |

▽ : Ground Points

| Code | See Page | Ground Points Location |
|------|----------|------------------------|
| IF | 42 | Cowl Brace LH |

Headlight

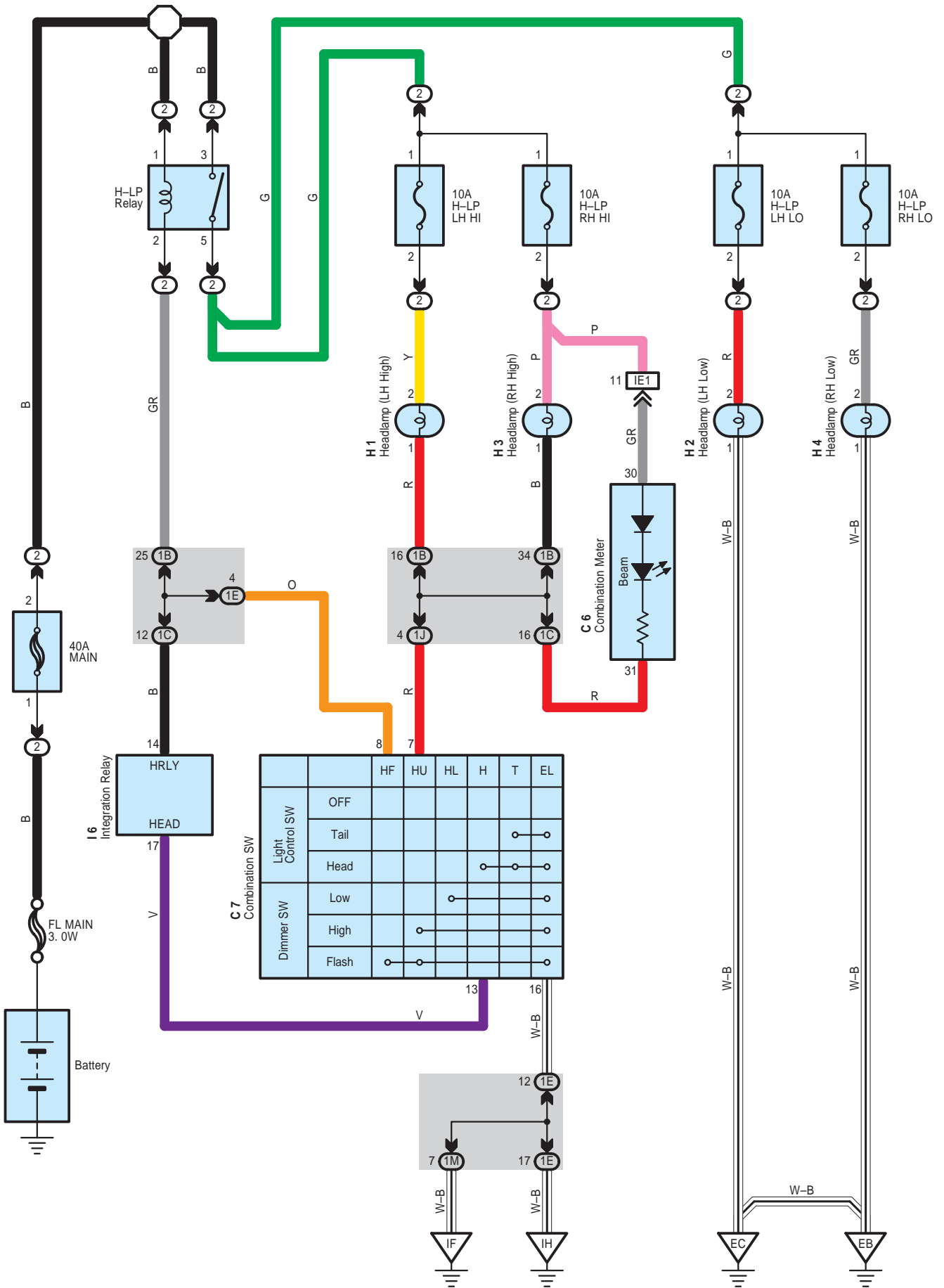

 : **Parts Location**

| Code | See Page | Code | See Page | Code | See Page |
|------|----------|------|----------|------|----------|
| C6 | 36 | H2 | 34 | I6 | 37 |
| C7 | 36 | H3 | 34 | | |
| H1 | 34 | H4 | 34 | | |

 : **Relay Blocks**

| Code | See Page | Relay Blocks (Relay Block Location) |
|------|----------|---|
| 2 | 22 | Engine Room R/B (Engine Compartment Left) |

 : **Junction Block and Wire Harness Connector**

| Code | See Page | Junction Block and Wire Harness (Connector Location) |
|------|----------|---|
| 1B | 24 | Engine Room Main Wire and Instrument Panel J/B (Lower Finish Panel) |
| 1C | 24 | Instrument Panel Wire and Instrument Panel J/B (Lower Finish Panel) |
| 1E | | |
| 1J | | |
| 1M | 25 | |

 : **Connector Joining Wire Harness and Wire Harness**

| Code | See Page | Joining Wire Harness and Wire Harness (Connector Location) |
|------|----------|---|
| IE1 | 42 | Engine Room Main Wire and Instrument Panel Wire (Behind of the Combination Meter) |

 : **Ground Points**

| Code | See Page | Ground Points Location |
|------|----------|------------------------|
| EB | 40 | Front Right Fender |
| EC | 40 | Front Left Fender |
| IF | 42 | Cowl Brace LH |
| IH | 42 | Cowl Brace RH |

Turn Signal and Hazard Warning Light

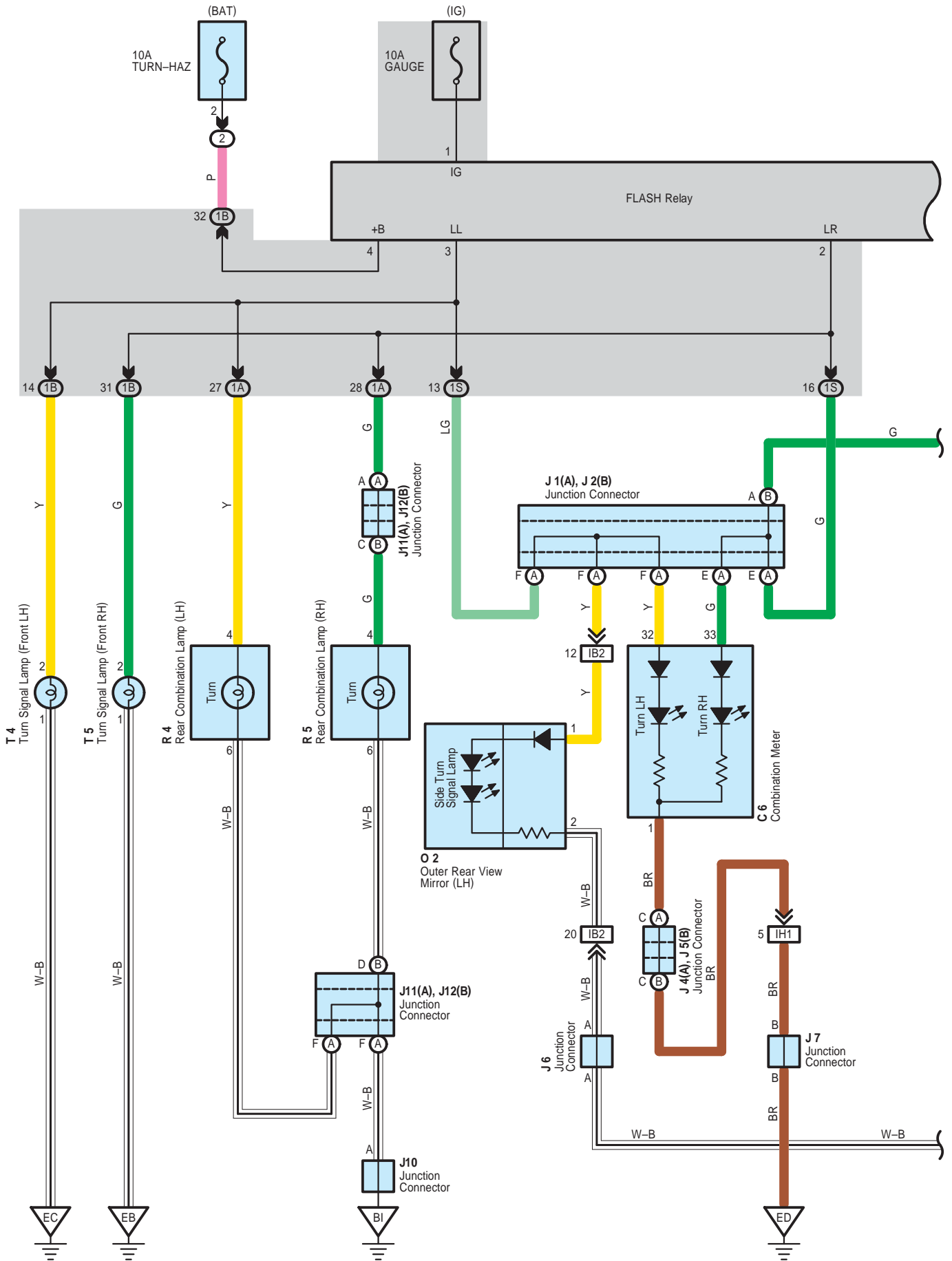

* 1 : w/ Cruise Control
 * 2 : w/o Cruise Control

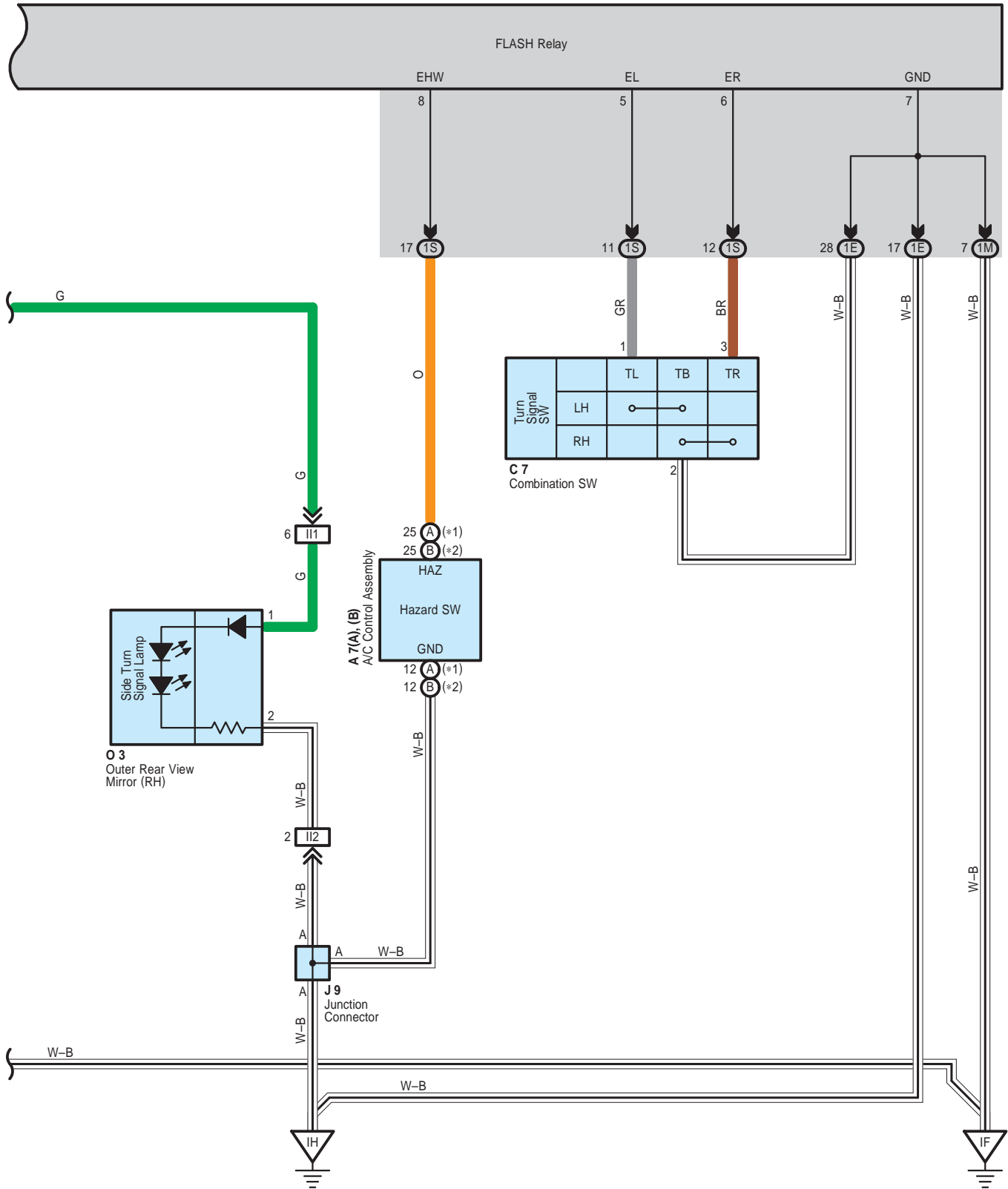

Turn Signal and Hazard Warning Light

: Parts Location

| Code | | See Page | Code | | See Page | Code | See Page |
|------|---|----------|------|---|----------|------|----------|
| A7 | A | 36 | J5 | B | 37 | O2 | 39 |
| | B | 36 | J6 | | 37 | O3 | 39 |
| C6 | | 36 | J7 | | 37 | R4 | 39 |
| C7 | | 36 | J9 | | 37 | R5 | 39 |
| J1 | A | 37 | J10 | | 38 | T4 | 35 |
| J2 | B | 37 | J11 | A | 38 | T5 | 35 |
| J4 | A | 37 | J12 | B | 38 | | |

: Relay Blocks

| Code | See Page | Relay Blocks (Relay Block Location) |
|------|----------|---|
| 2 | 22 | Engine Room R/B (Engine Compartment Left) |

: Junction Block and Wire Harness Connector

| Code | See Page | Junction Block and Wire Harness (Connector Location) |
|------|----------|---|
| 1A | 24 | Floor Wire and Instrument Panel J/B (Lower Finish Panel) |
| 1B | 24 | Engine Room Main Wire and Instrument Panel J/B (Lower Finish Panel) |
| 1E | 24 | Instrument Panel Wire and Instrument Panel J/B (Lower Finish Panel) |
| 1M | 25 | |
| 1S | | |

: Connector Joining Wire Harness and Wire Harness

| Code | See Page | Joining Wire Harness and Wire Harness (Connector Location) |
|------|----------|---|
| IB2 | 42 | Front Door LH Wire and Instrument Panel Wire (Left Kick Panel) |
| IH1 | 43 | Engine Wire and Instrument Panel Wire (Cowl Side Panel RH) |
| II1 | 43 | Front Door RH Wire and Instrument Panel Wire (Right Kick Panel) |
| II2 | | |

: Ground Points

| Code | See Page | Ground Points Location |
|------|----------|--------------------------------------|
| EB | 40 | Front Right Fender |
| EC | 40 | Front Left Fender |
| ED | 40 | Front Left Side of the Cylinder Head |
| IF | 42 | Cowl Brace LH |
| IH | 42 | Cowl Brace RH |
| BI | 44 | Quarter Panel LH |

Interior Light

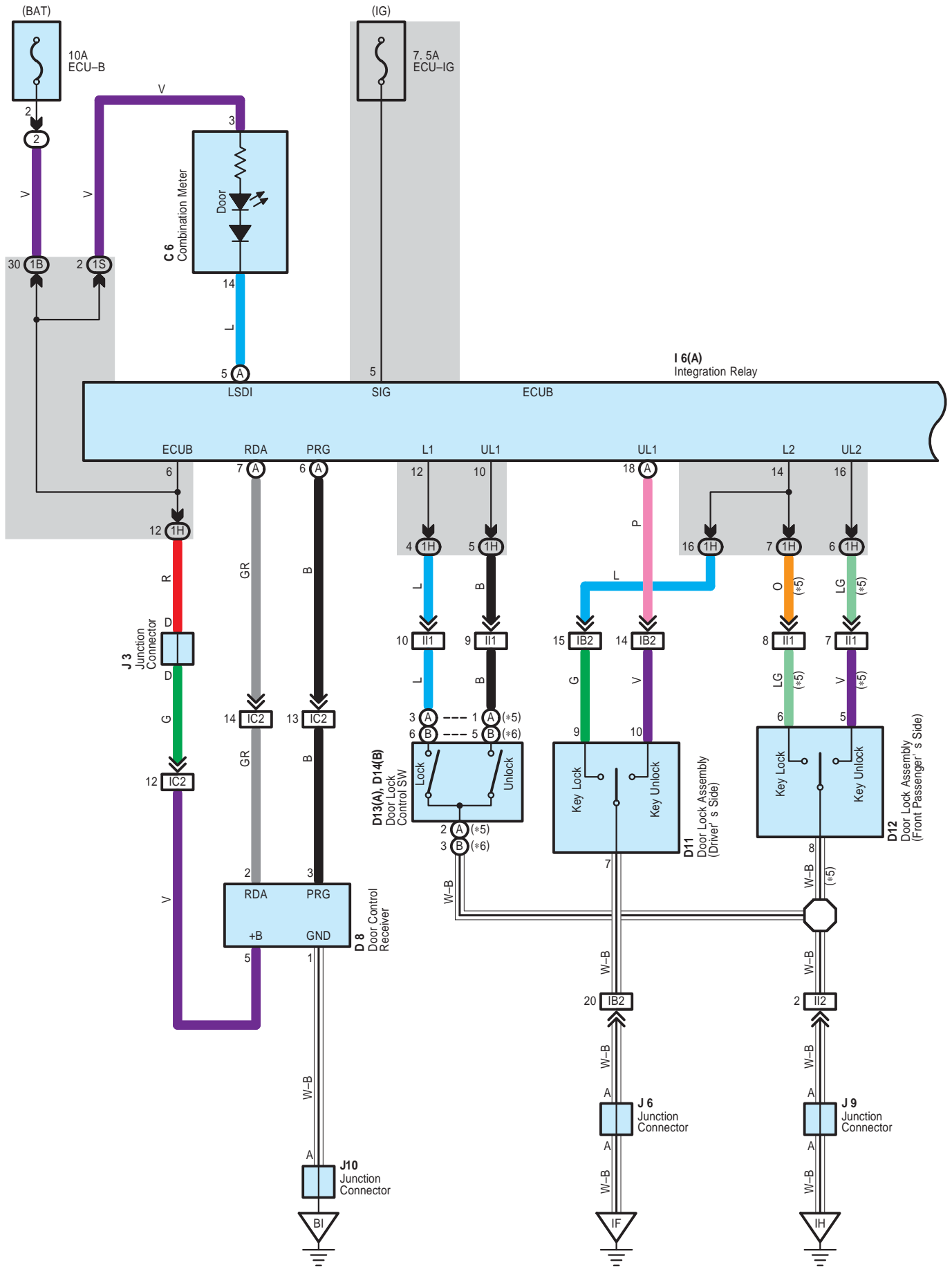

- * 1 : w/ Engine Immobiliser System
- * 2 : w/o Engine Immobiliser System
- * 5 : w/ Jam Protection
- * 6 : w/o Jam Protection

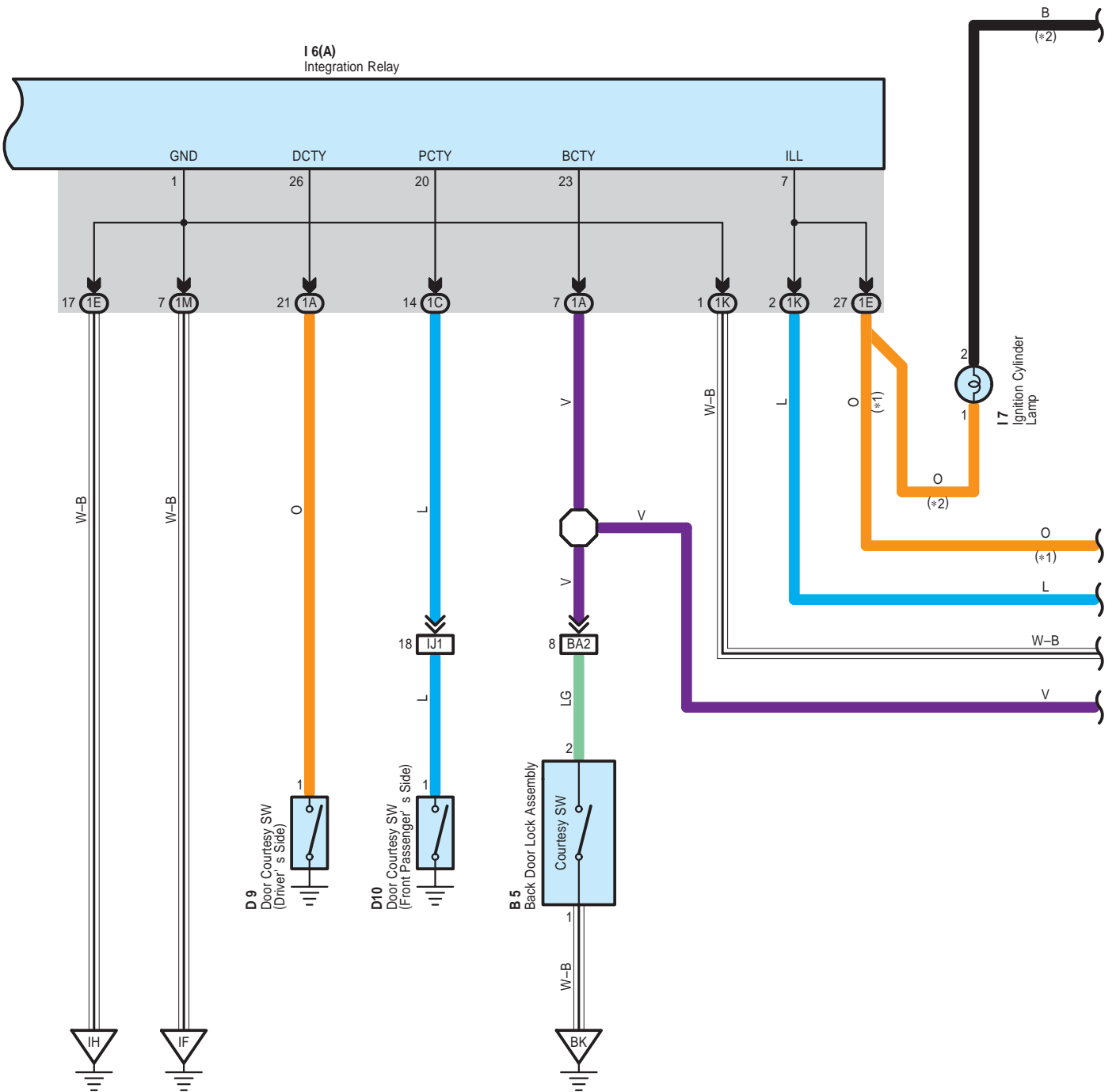

Interior Light

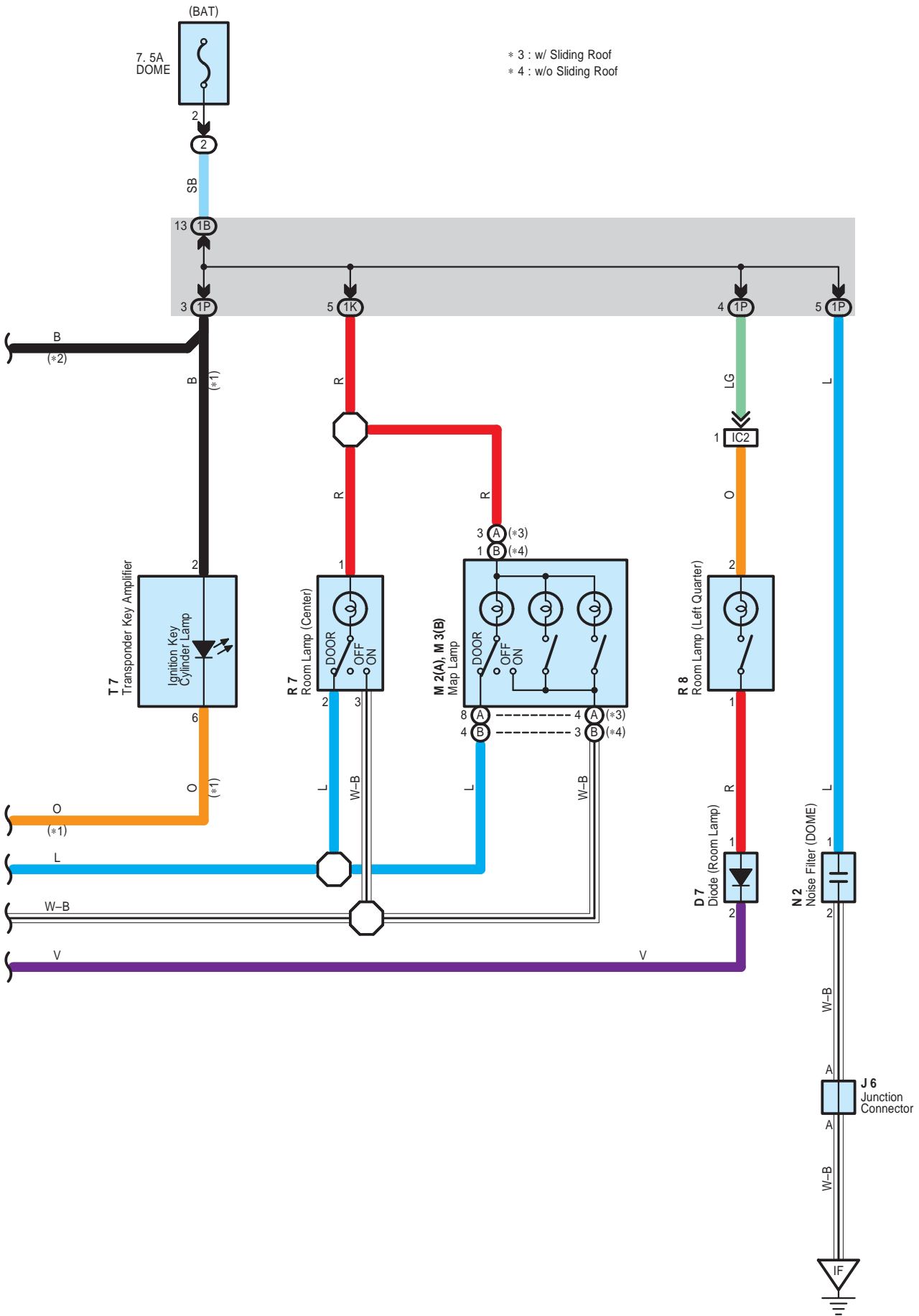

System Outline

The interior light is controlled by the integration relay. This system has following features.

Illuminated Entry System

- * When a door is unlocked through a key operation or transmitter operation, or if a door is opened or closed, the illuminated entry system turns ON the room lamp (Center), map lamp and the ignition key cylinder lamp.
- * If the ignition switch is turned to the ACC or ON position or if all doors are locked during the 15 seconds in which these lights are ON, they will immediately turn OFF.

: Parts Location

| Code | See Page | Code | See Page | Code | See Page | | |
|------|----------|------|----------|------|----------|---|----|
| B5 | 38 | D13 | A | 38 | M2 | A | 38 |
| C6 | 36 | D14 | B | 38 | M3 | B | 38 |
| D7 | 38 | I6 | A | 37 | N2 | | 37 |
| D8 | 38 | I7 | | 37 | R7 | | 39 |
| D9 | 38 | J3 | | 37 | R8 | | 39 |
| D10 | 38 | J6 | | 37 | T7 | | 37 |
| D11 | 38 | J9 | | 37 | | | |
| D12 | 38 | J10 | | 38 | | | |

: Relay Blocks

| Code | See Page | Relay Blocks (Relay Block Location) |
|------|----------|---|
| 2 | 22 | Engine Room R/B (Engine Compartment Left) |

: Junction Block and Wire Harness Connector

| Code | See Page | Junction Block and Wire Harness (Connector Location) |
|------|----------|---|
| 1A | 24 | Floor Wire and Instrument Panel J/B (Lower Finish Panel) |
| 1B | 24 | Engine Room Main Wire and Instrument Panel J/B (Lower Finish Panel) |
| 1C | 24 | Instrument Panel Wire and Instrument Panel J/B (Lower Finish Panel) |
| 1E | | |
| 1H | | |
| 1K | 24 | Roof Wire and Instrument Panel J/B (Lower Finish Panel) |
| 1M | 25 | Instrument Panel Wire and Instrument Panel J/B (Lower Finish Panel) |
| 1P | | |
| 1S | | |

: Connector Joining Wire Harness and Wire Harness

| Code | See Page | Joining Wire Harness and Wire Harness (Connector Location) |
|------|----------|---|
| IB2 | 42 | Front Door LH Wire and Instrument Panel Wire (Left Kick Panel) |
| IC2 | 42 | Floor Wire and Instrument Panel Wire (Left Kick Panel) |
| II1 | 43 | Front Door RH Wire and Instrument Panel Wire (Right Kick Panel) |
| II2 | | |
| IJ1 | 43 | Floor No.2 Wire and Instrument Panel Wire (Right Kick Panel) |
| BA2 | 44 | Back Door No.1 Wire and Floor Wire (Back Window Upper Frame LH) |

: Ground Points

| Code | See Page | Ground Points Location |
|------|----------|----------------------------------|
| IF | 42 | Cowl Brace LH |
| IH | 42 | Cowl Brace RH |
| BI | 44 | Quarter Panel LH |
| BK | 44 | Left Side of the Back Door Panel |

- * 1 : w/ Front Console Illumination
- * 2 : w/ Audio Steering Pad SW
- * 3 : w/ Cruise Control
- * 4 : w/o Cruise Control

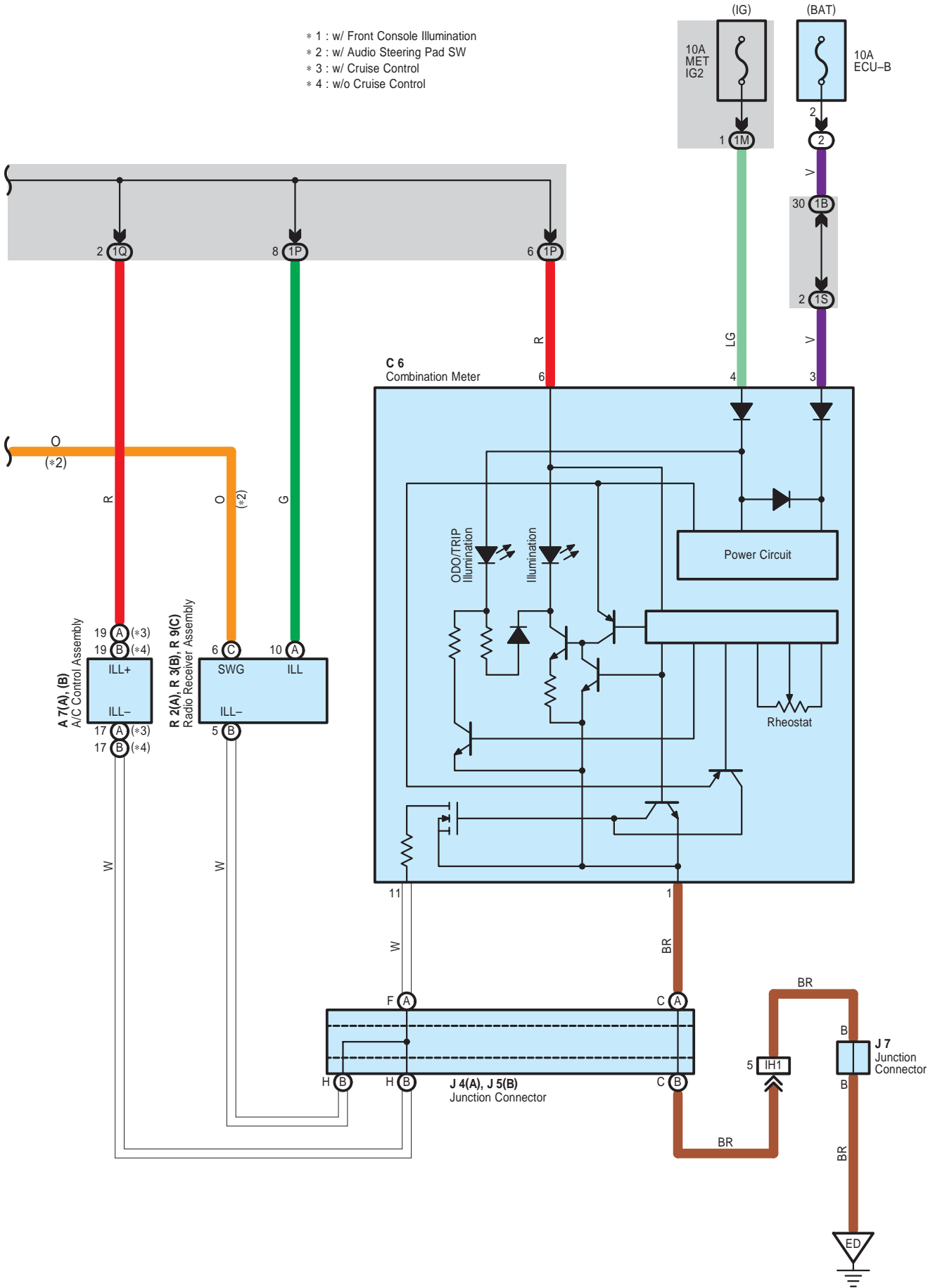

Illumination

: Parts Location

| Code | See Page | Code | See Page | Code | See Page | | |
|------|----------|------|----------|------|----------|----|----|
| A7 | A | 36 | F5 | 36 | R2 | A | 37 |
| | B | 36 | I6 | A | 37 | R3 | B |
| A9 | 36 | J4 | A | 37 | R9 | C | 37 |
| C6 | 36 | J5 | B | 37 | S7 | | 37 |
| C7 | 36 | J7 | | 37 | | | |
| D13 | 38 | J9 | | 37 | | | |

: Relay Blocks

| Code | See Page | Relay Blocks (Relay Block Location) |
|------|----------|---|
| 2 | 22 | Engine Room R/B (Engine Compartment Left) |

: Junction Block and Wire Harness Connector

| Code | See Page | Junction Block and Wire Harness (Connector Location) |
|------|----------|---|
| 1B | 24 | Engine Room Main Wire and Instrument Panel J/B (Lower Finish Panel) |
| 1D | 24 | Instrument Panel Wire and Instrument Panel J/B (Lower Finish Panel) |
| 1E | | |
| 1G | 24 | Engine Room Main Wire and Instrument Panel J/B (Lower Finish Panel) |
| 1M | 25 | Instrument Panel Wire and Instrument Panel J/B (Lower Finish Panel) |
| 1P | | |
| 1Q | | |
| 1S | | |

: Connector Joining Wire Harness and Wire Harness

| Code | See Page | Joining Wire Harness and Wire Harness (Connector Location) |
|------|----------|---|
| IH1 | 43 | Engine Wire and Instrument Panel Wire (Cowl Side Panel RH) |
| II1 | 43 | Front Door RH Wire and Instrument Panel Wire (Right Kick Panel) |
| II2 | | |

: Ground Points

| Code | See Page | Ground Points Location |
|------|----------|--------------------------------------|
| ED | 40 | Front Left Side of the Cylinder Head |
| IF | 42 | Cowl Brace LH |
| IH | 42 | Cowl Brace RH |

 : **Parts Location**

| Code | See Page | Code | See Page | Code | See Page | |
|------|----------|------|----------|------|----------|----|
| C7 | 36 | J12 | B | 38 | P3 | 35 |
| I6 | A | 37 | L2 | 38 | R4 | 39 |
| J10 | 38 | L3 | 38 | R5 | 39 | |
| J11 | A | 38 | P2 | 35 | | |

 : **Relay Blocks**

| Code | See Page | Relay Blocks (Relay Block Location) |
|------|----------|---|
| 2 | 22 | Engine Room R/B (Engine Compartment Left) |

 : **Junction Block and Wire Harness Connector**

| Code | See Page | Junction Block and Wire Harness (Connector Location) |
|------|----------|---|
| 1A | 24 | Floor Wire and Instrument Panel J/B (Lower Finish Panel) |
| 1B | 24 | Engine Room Main Wire and Instrument Panel J/B (Lower Finish Panel) |
| 1E | 24 | Instrument Panel Wire and Instrument Panel J/B (Lower Finish Panel) |
| 1G | 24 | Engine Room Main Wire and Instrument Panel J/B (Lower Finish Panel) |
| 1M | 25 | Instrument Panel Wire and Instrument Panel J/B (Lower Finish Panel) |

 : **Connector Joining Wire Harness and Wire Harness**

| Code | See Page | Joining Wire Harness and Wire Harness (Connector Location) |
|------|----------|---|
| BA1 | 44 | Back Door No.1 Wire and Floor Wire (Back Window Upper Frame LH) |
| BA2 | | |

 : **Ground Points**

| Code | See Page | Ground Points Location |
|------|----------|----------------------------------|
| EB | 40 | Front Right Fender |
| EC | 40 | Front Left Fender |
| IF | 42 | Cowl Brace LH |
| IH | 42 | Cowl Brace RH |
| BI | 44 | Quarter Panel LH |
| BJ | | |
| BK | 44 | Left Side of the Back Door Panel |

Stop Light

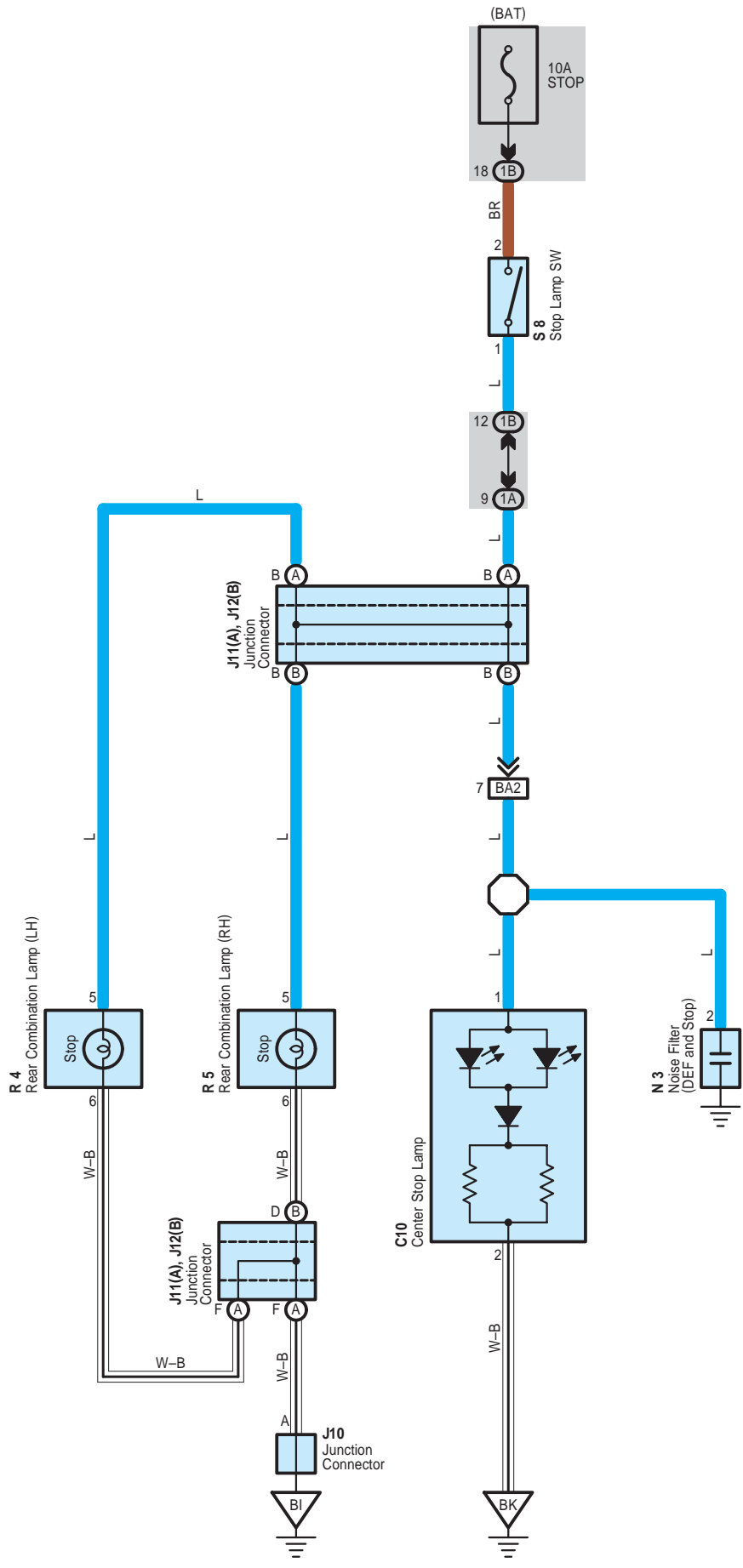

 : **Parts Location**

| Code | See Page | Code | See Page | Code | See Page | |
|------|----------|------|----------|------|----------|----|
| C10 | 38 | J12 | B | 38 | R5 | 39 |
| J10 | 38 | N3 | | 38 | S8 | 37 |
| J11 | A | R4 | | 39 | | |

 : **Junction Block and Wire Harness Connector**

| Code | See Page | Junction Block and Wire Harness (Connector Location) |
|------|----------|---|
| 1A | 24 | Floor Wire and Instrument Panel J/B (Lower Finish Panel) |
| 1B | 24 | Engine Room Main Wire and Instrument Panel J/B (Lower Finish Panel) |

 : **Connector Joining Wire Harness and Wire Harness**

| Code | See Page | Joining Wire Harness and Wire Harness (Connector Location) |
|------|----------|---|
| BA2 | 44 | Back Door No.1 Wire and Floor Wire (Back Window Upper Frame LH) |

 : **Ground Points**

| Code | See Page | Ground Points Location |
|------|----------|----------------------------------|
| BI | 44 | Quarter Panel LH |
| BK | 44 | Left Side of the Back Door Panel |

Back-Up Light

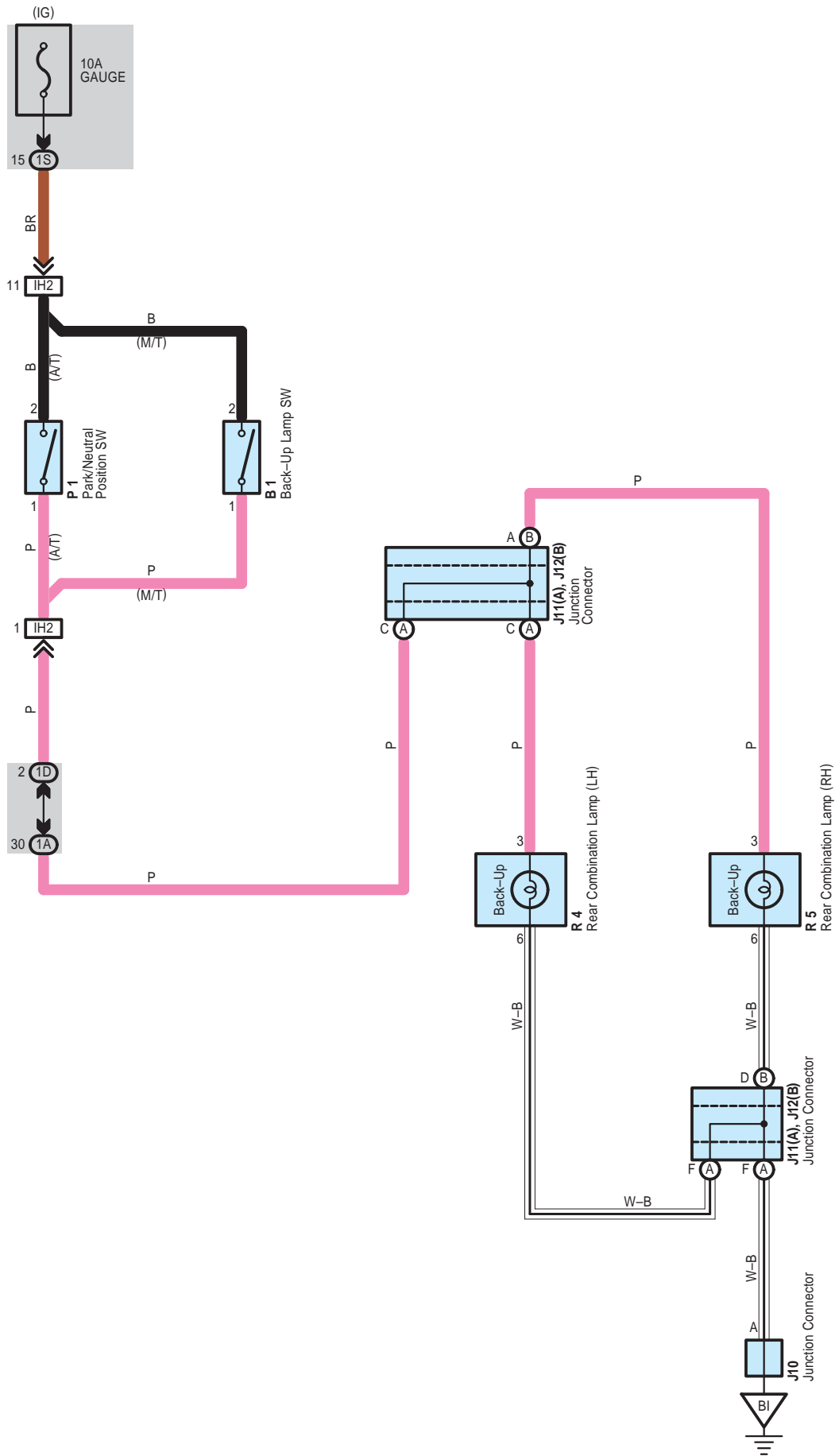

 : **Parts Location**

| Code | See Page | Code | See Page | Code | See Page |
|---------|----------|---------|----------|------|----------|
| B1 | 34 | J12 B | 38 | R5 | 39 |
| J10 | 38 | P1 | 35 | | |
| J11 A | 38 | R4 | 39 | | |

 : **Junction Block and Wire Harness Connector**

| Code | See Page | Junction Block and Wire Harness (Connector Location) |
|------|----------|---|
| 1A | 24 | Floor Wire and Instrument Panel J/B (Lower Finish Panel) |
| 1D | 24 | Instrument Panel Wire and Instrument Panel J/B (Lower Finish Panel) |
| 1S | 25 | |

 : **Connector Joining Wire Harness and Wire Harness**

| Code | See Page | Joining Wire Harness and Wire Harness (Connector Location) |
|------|----------|--|
| IH2 | 43 | Engine Wire and Instrument Panel Wire (Cowl Side Panel RH) |

 : **Ground Points**

| Code | See Page | Ground Points Location |
|------|----------|------------------------|
| BI | 44 | Quarter Panel LH |

System Outline

With the ignition SW turned on, the current flows to TERMINAL 17 of the wiper and washer SW and TERMINAL 2 of the windshield wiper motor through the FR WIP fuse. The current flows to TERMINAL 1 of the windshield washer motor through the FR WSH fuse.

1. Low Speed Position

With the wiper and washer SW turned to LO position, the current flows from TERMINAL 17 of the wiper and washer SW to TERMINAL 7 to TERMINAL 1 of the windshield wiper motor to TERMINAL 5 to GROUND and causes the windshield wiper motor to run at low speed.

2. High Speed Position

With the wiper and washer SW turned to HI position, the current flows from TERMINAL 17 of the wiper and washer SW to TERMINAL 8 to TERMINAL 4 of the windshield wiper motor to TERMINAL 5 to GROUND and causes the windshield wiper motor to run at high speed.

3. INT Position

With the wiper and washer SW turned to INT position, the wiper relay operates and current flows from TERMINAL 17 of the wiper and washer SW to TERMINAL 2 to GROUND. This activates the intermittent circuit and the current flows from TERMINAL 17 of the wiper and washer SW to TERMINAL 7 to TERMINAL 1 of the windshield wiper motor to TERMINAL 5 to GROUND and the wiper operates. Intermittent operation is controlled by a condenser charge and discharge function in the relay.

4. Washer Continuous Operation

With the wiper and washer SW pulled to WASHER position (Washer SW ON position), the current flows from the FR WSH fuse to TERMINAL 1 of the windshield washer motor to TERMINAL 2 to TERMINAL 11 of the wiper and washer SW to TERMINAL 2 to GROUND and causes the windshield washer motor to run and the window washer to spray. Simultaneously, current flows from the FR WIP fuse to TERMINAL 17 of the wiper and washer SW to TERMINAL 7 to TERMINAL 1 of the windshield wiper motor to TERMINAL 5 to GROUND, causing the wiper to function.

○ : Parts Location

| Code | See Page | Code | See Page | Code | See Page |
|------|----------|------|----------|------|----------|
| C8 | 36 | W1 | 35 | W2 | 35 |

○ : Junction Block and Wire Harness Connector

| Code | See Page | Junction Block and Wire Harness (Connector Location) |
|------|----------|---|
| 1B | 24 | Engine Room Main Wire and Instrument Panel J/B (Lower Finish Panel) |
| 1E | 24 | Instrument Panel Wire and Instrument Panel J/B (Lower Finish Panel) |
| 1J | | |
| 1M | 25 | |

□ : Connector Joining Wire Harness and Wire Harness

| Code | See Page | Joining Wire Harness and Wire Harness (Connector Location) |
|------|----------|---|
| IE1 | 42 | Engine Room Main Wire and Instrument Panel Wire (Behind of the Combination Meter) |

▽ : Ground Points

| Code | See Page | Ground Points Location |
|------|----------|------------------------|
| EB | 40 | Front Right Fender |
| IF | 42 | Cowl Brace LH |
| IH | 42 | Cowl Brace RH |

Remote Control Mirror

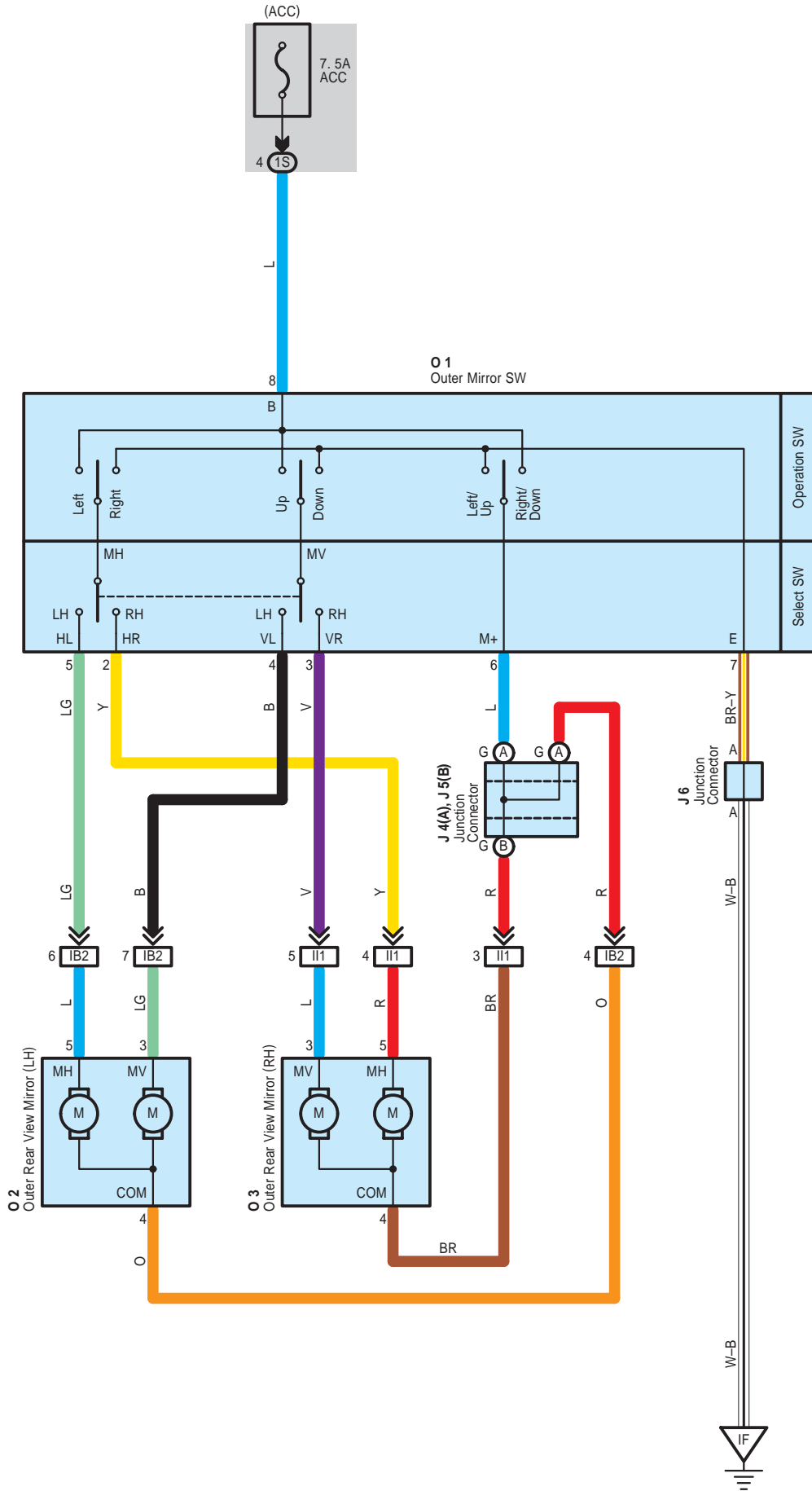

 : **Parts Location**

| Code | | See Page | Code | See Page | Code | See Page |
|------|---|----------|------|----------|------|----------|
| J4 | A | 37 | J6 | 37 | O2 | 39 |
| J5 | B | 37 | O1 | 37 | O3 | 39 |

 : **Junction Block and Wire Harness Connector**

| Code | See Page | Junction Block and Wire Harness (Connector Location) |
|------|----------|---|
| 1S | 25 | Instrument Panel Wire and Instrument Panel J/B (Lower Finish Panel) |

 : **Connector Joining Wire Harness and Wire Harness**

| Code | See Page | Joining Wire Harness and Wire Harness (Connector Location) |
|------|----------|---|
| IB2 | 42 | Front Door LH Wire and Instrument Panel Wire (Left Kick Panel) |
| II1 | 43 | Front Door RH Wire and Instrument Panel Wire (Right Kick Panel) |

 : **Ground Points**

| Code | See Page | Ground Points Location |
|------|----------|------------------------|
| IF | 42 | Cowl Brace LH |

Power Window with Jam Protection

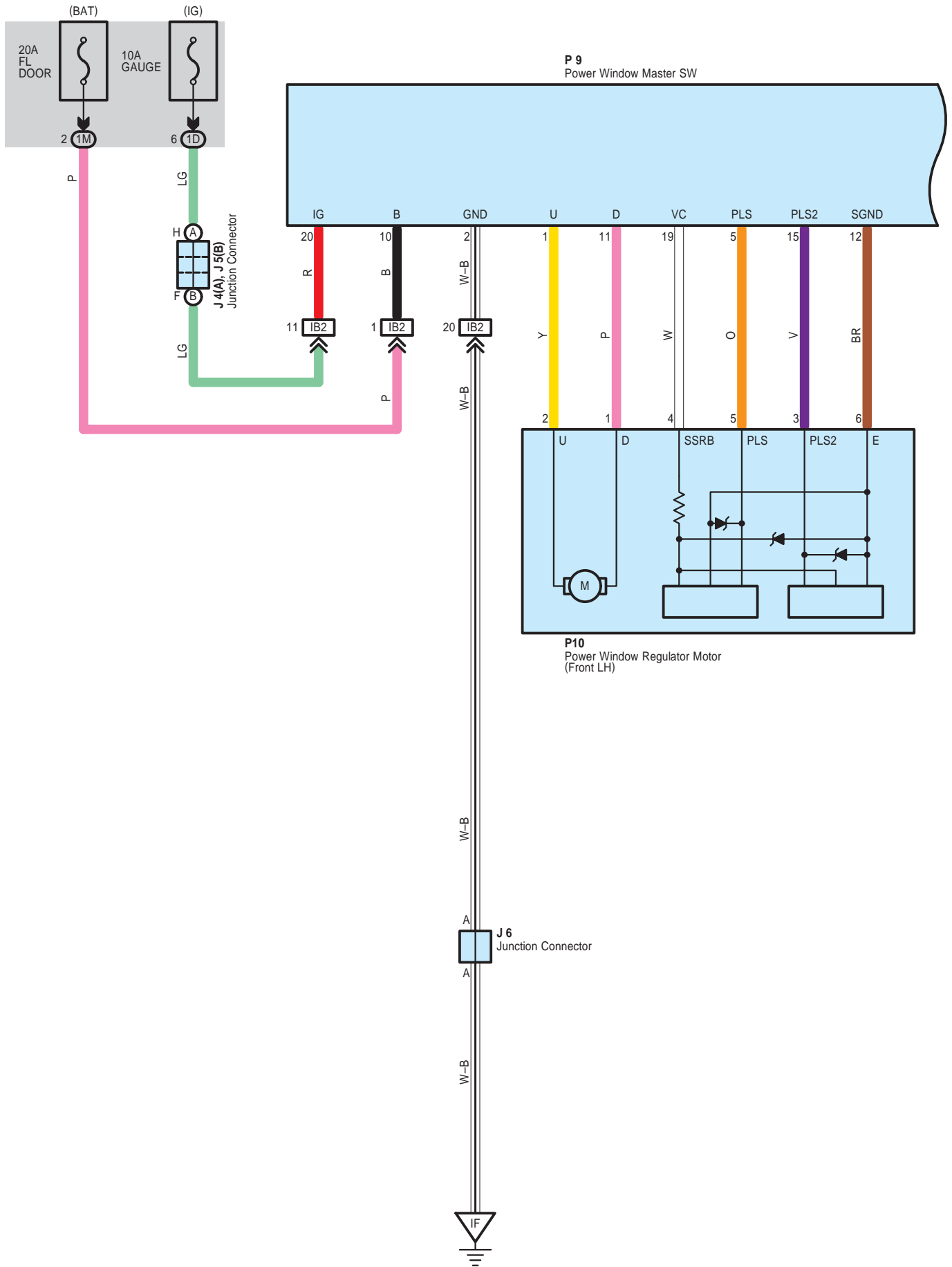

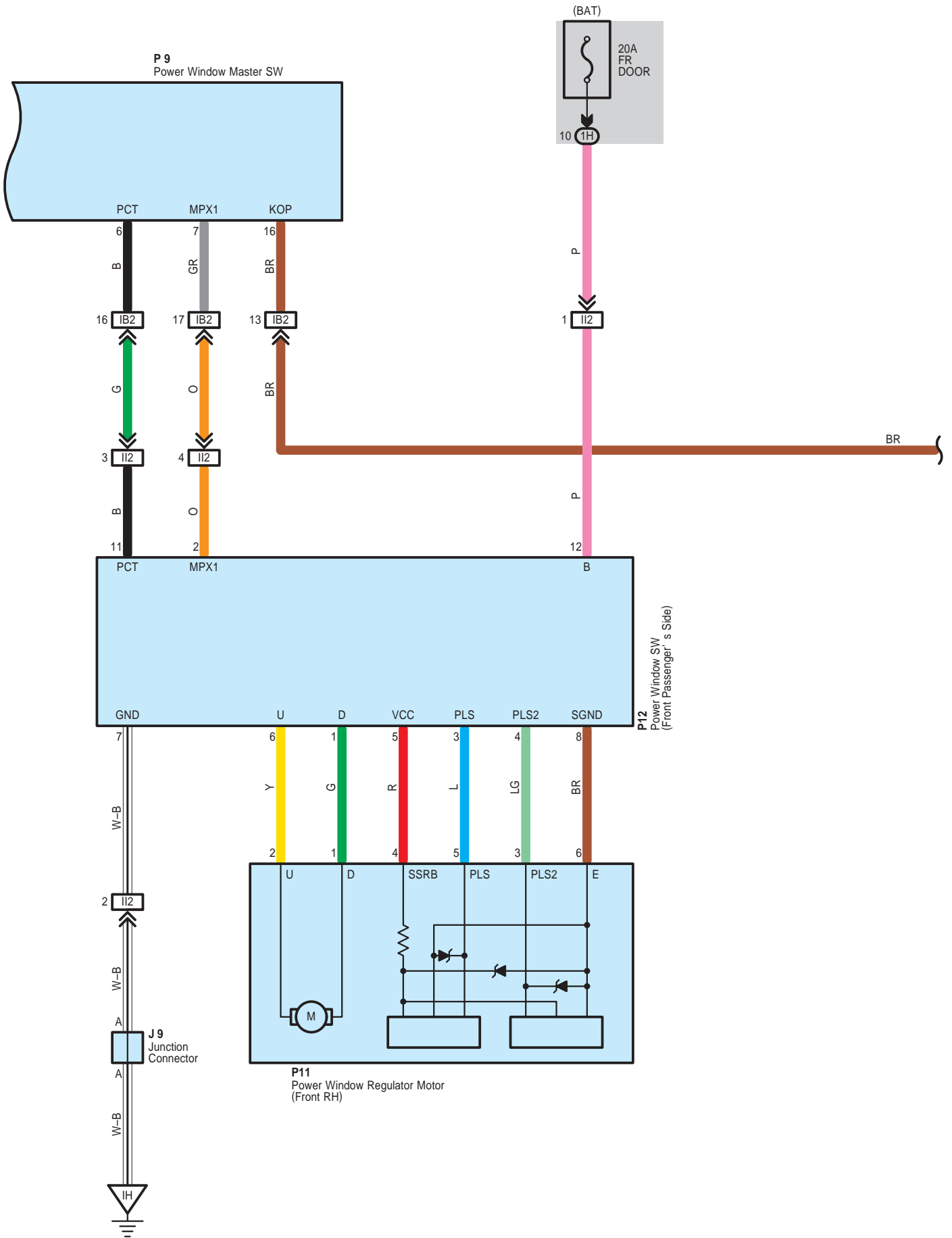

Power Window with Jam Protection

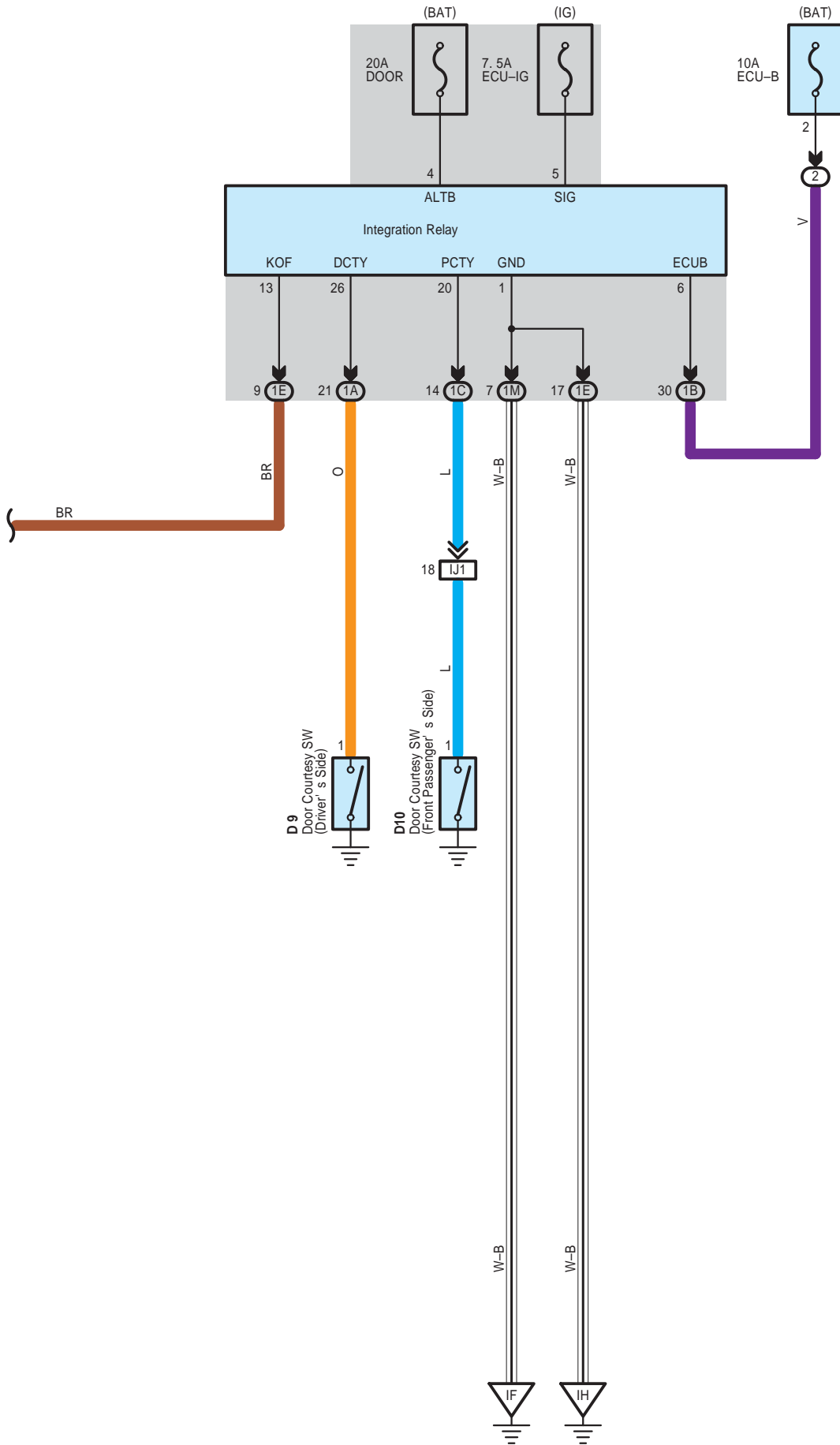

System Outline

1. Manual Up and Down Function

This function operates the window to open or close while the power window switch is being pulled up or pushed down (Should be pulled up and down halfway for manual operation.). The window stops as soon as the switch is released.

2. One-Touch Auto Up and Down Function

"One-touch auto up and down function" enables the window of front doors to be fully opened or closed with a touch of the power window switch.

3. Jam Protection Function

The jam protection function automatically stops the power window and moves it downward if a foreign object gets jammed in the course of the window during one-touch auto-up operation.

4. Remote Control Function

The up and down operation of the front passenger door windows can be controlled by operating the power window master switch.

5. Key-Off Operation Function

Within about 43 seconds when turn OFF the ignition SW or until the driver's or passenger's door is opened, this function enables the door window operation with the power window master switch and/or the manual operation at each passenger's seat door.

* When the battery terminal or fuse is disconnected, the glass position of all door windows have to be reset to the initial positions, one by one, with the power window control switch by following the procedure below:

- A) Reconnect the battery terminal or fuse.
- B) Turn ON the ignition switch.
- C) Lower the window of each door halfway or more with the power window switch.
- D) Then close the window fully with the power window switch.
Do not release the switch for at least 2 seconds after the window is fully closed.

: Parts Location

| Code | See Page | Code | See Page | Code | See Page |
|------|----------|------|----------|------|----------|
| D9 | 38 | J6 | 37 | P11 | 39 |
| D10 | 38 | J9 | 37 | P12 | 39 |
| J4 | A 37 | P9 | 39 | | |
| J5 | B 37 | P10 | 39 | | |

: Relay Blocks

| Code | See Page | Relay Blocks (Relay Block Location) |
|------|----------|---|
| 2 | 22 | Engine Room R/B (Engine Compartment Left) |

: Junction Block and Wire Harness Connector

| Code | See Page | Junction Block and Wire Harness (Connector Location) |
|------|----------|---|
| 1A | 24 | Floor Wire and Instrument Panel J/B (Lower Finish Panel) |
| 1B | 24 | Engine Room Main Wire and Instrument Panel J/B (Lower Finish Panel) |
| 1C | 24 | Instrument Panel Wire and Instrument Panel J/B (Lower Finish Panel) |
| 1D | | |
| 1E | | |
| 1H | | |
| 1M | 25 | |

: Connector Joining Wire Harness and Wire Harness

| Code | See Page | Joining Wire Harness and Wire Harness (Connector Location) |
|------|----------|---|
| IB2 | 42 | Front Door LH Wire and Instrument Panel Wire (Left Kick Panel) |
| II2 | 43 | Front Door RH Wire and Instrument Panel Wire (Right Kick Panel) |
| IJ1 | 43 | Floor No.2 Wire and Instrument Panel Wire (Right Kick Panel) |

Power Window with Jam Protection



: Ground Points

| Code | See Page | Ground Points Location |
|------|----------|------------------------|
| IF | 42 | Cowl Brace LH |
| IH | 42 | Cowl Brace RH |

Power Window without Jam Protection

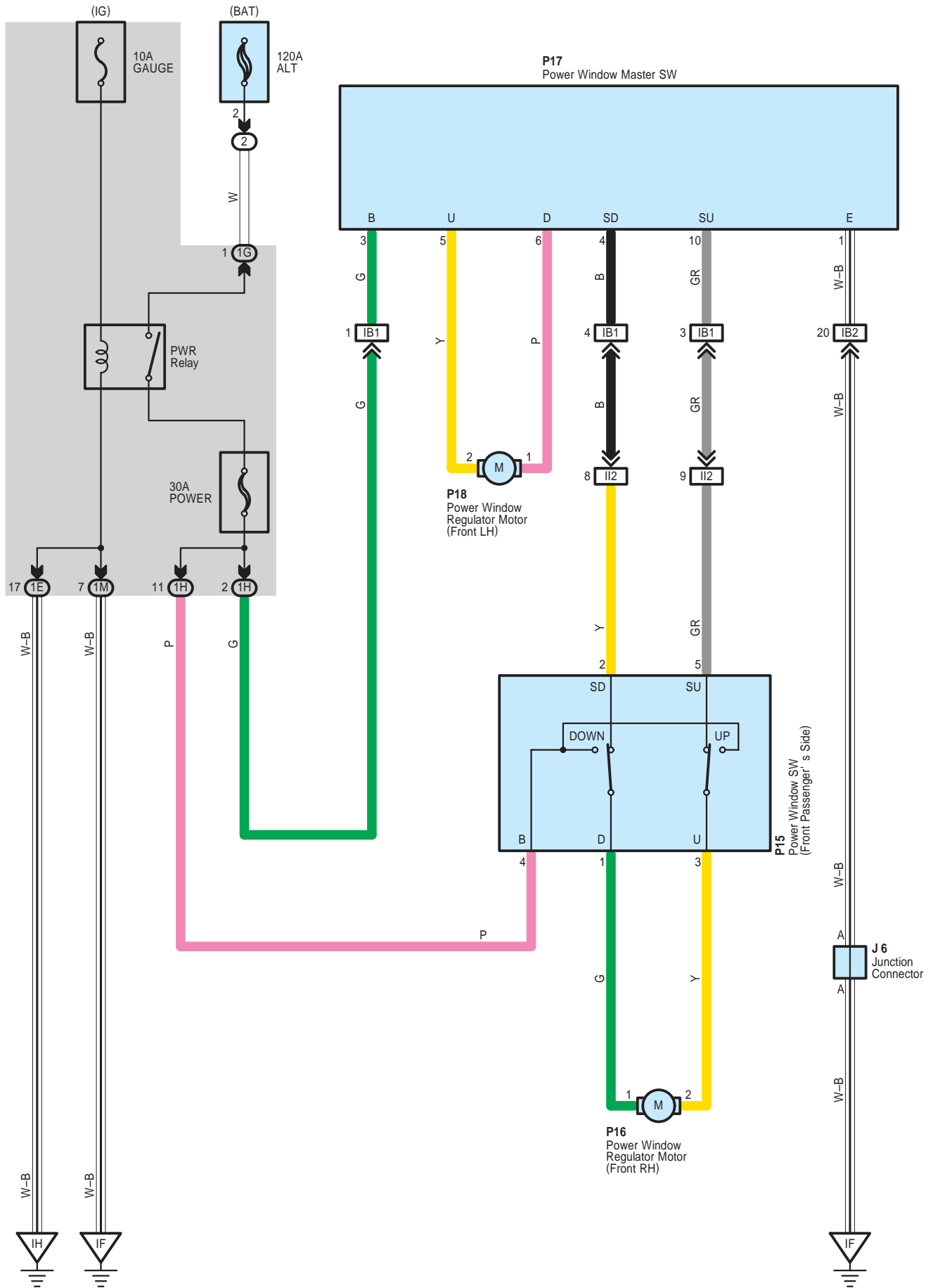

System Outline

1. Manual Down or Up Operation

When the power window master SW is pushed one stop, the motor rotates to open the window.

When the power window master SW is pulled up one step, the motor rotates in the opposite direction, to close the window.

All the other windows can be opened/closed as well, by the operation of the power window master SW or respective power window SW.

When the window lock SW is pushed to the lock side, the ground circuit to the passenger's window becomes open. As a result, even if Open/Close operation of the passenger's window is attempted, the current from TERMINAL E of the power window master SW is not grounded and the motor does not rotate, to the passenger's window can not be operated and window lock occurs.

2. Auto Down Operation (Driver's Window)

When the power window master SW is pushed two steps, the motor rotates to open the window automatically.

3. Stopping of Auto Down Operation (Driver's Window)

Auto operation can be stopped in mid-course with switching power window master SW one step upward during the down operation.

: Parts Location

| Code | See Page | Code | See Page | Code | See Page |
|------|----------|------|----------|------|----------|
| J6 | 37 | P16 | 39 | P18 | 39 |
| P15 | 39 | P17 | 39 | | |

: Relay Blocks

| Code | See Page | Relay Blocks (Relay Block Location) |
|------|----------|---|
| 2 | 22 | Engine Room R/B (Engine Compartment Left) |

: Junction Block and Wire Harness Connector

| Code | See Page | Junction Block and Wire Harness (Connector Location) |
|------|----------|---|
| 1E | 24 | Instrument Panel Wire and Instrument Panel J/B (Lower Finish Panel) |
| 1G | 24 | Engine Room Main Wire and Instrument Panel J/B (Lower Finish Panel) |
| 1H | 24 | Instrument Panel Wire and Instrument Panel J/B (Lower Finish Panel) |
| 1M | 25 | |

: Connector Joining Wire Harness and Wire Harness

| Code | See Page | Joining Wire Harness and Wire Harness (Connector Location) |
|------|----------|---|
| IB1 | 42 | Front Door LH Wire and Instrument Panel Wire (Left Kick Panel) |
| IB2 | | |
| II2 | 43 | Front Door RH Wire and Instrument Panel Wire (Right Kick Panel) |

: Ground Points

| Code | See Page | Ground Points Location |
|------|----------|------------------------|
| IF | 42 | Cowl Brace LH |
| IH | 42 | Cowl Brace RH |

Door Lock Control

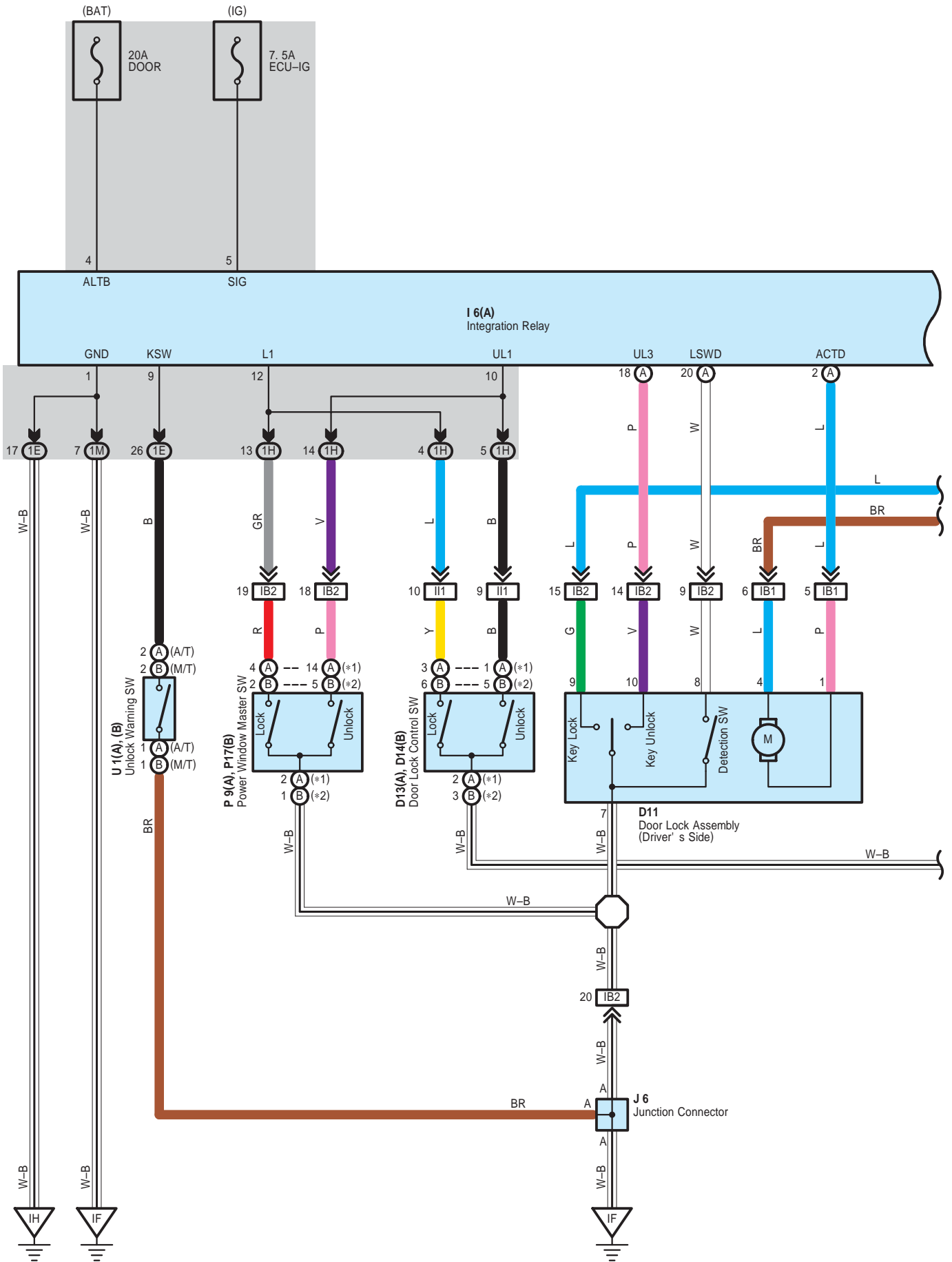

* 1 : w/ Jam Protection
 * 2 : w/o Jam Protection

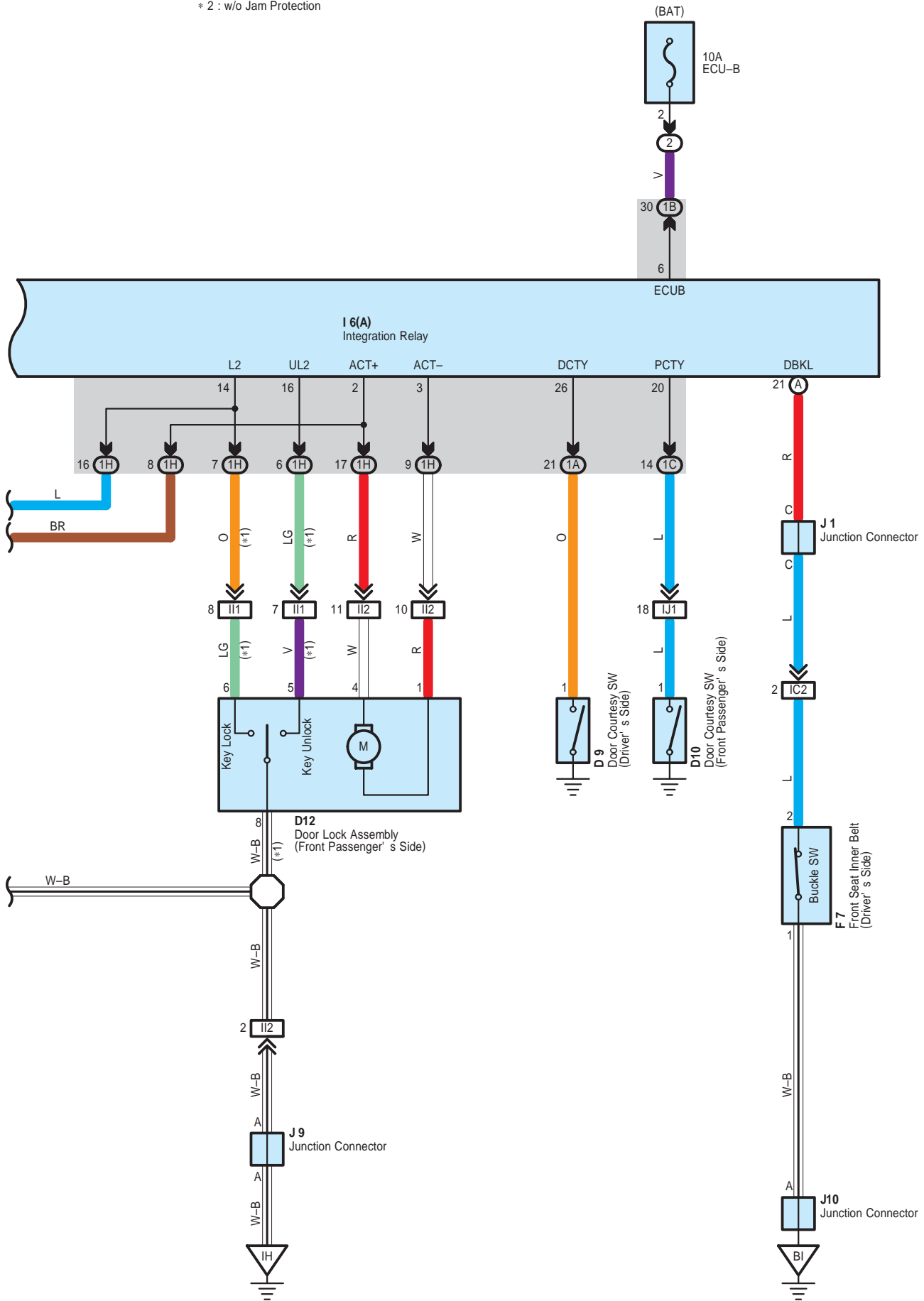

Door Lock Control

System Outline

The door lock control is a system controlled by various signals input into the integration relay.

1. Manual Unlock Operation

When the door lock control SW of the driver's or passenger's side door is pushed to UNLOCK, the door unlocks.

2. Manual Lock Operation

When the door lock control SW of the driver's or passenger's side door is pushed to LOCK, the door locks.

3. Door Key Unlock Operation

* Unlock operation from driver's side door

When the driver's side door is unlocked once using the mechanical key, only the driver's side door unlocks. If this operation is repeated within 3 seconds, all the other doors also unlock.

4. Ignition Key Reminder Operation

Under condition that the ignition key remains inserted in the ignition key cylinder and driver's side door is open, locking operation with door knob of driver's door is not effective but automatically unlocks the door. When the door is locked with the manual door lock SW of driver's door or door key SW of driver's door, the door locks once but right after that, the door unlocks automatically.

○ : Parts Location

| Code | See Page | Code | See Page | Code | See Page |
|------|----------|------|----------|------|----------|
| D9 | 38 | F7 | 38 | P9 | A 39 |
| D10 | 38 | I6 | A 37 | P17 | B 39 |
| D11 | 38 | J1 | 37 | U1 | A 37 |
| D12 | 38 | J6 | 37 | | B 37 |
| D13 | A 38 | J9 | 37 | | |
| D14 | B 38 | J10 | 38 | | |

○ : Relay Blocks

| Code | See Page | Relay Blocks (Relay Block Location) |
|------|----------|---|
| 2 | 22 | Engine Room R/B (Engine Compartment Left) |

○ : Junction Block and Wire Harness Connector

| Code | See Page | Junction Block and Wire Harness (Connector Location) |
|------|----------|---|
| 1A | 24 | Floor Wire and Instrument Panel J/B (Lower Finish Panel) |
| 1B | 24 | Engine Room Main Wire and Instrument Panel J/B (Lower Finish Panel) |
| 1C | 24 | Instrument Panel Wire and Instrument Panel J/B (Lower Finish Panel) |
| 1E | | |
| 1H | | |
| 1M | 25 | |

□ : Connector Joining Wire Harness and Wire Harness

| Code | See Page | Joining Wire Harness and Wire Harness (Connector Location) |
|------|----------|---|
| IB1 | 42 | Front Door LH Wire and Instrument Panel Wire (Left Kick Panel) |
| IB2 | | |
| IC2 | 42 | Floor Wire and Instrument Panel Wire (Left Kick Panel) |
| II1 | 43 | Front Door RH Wire and Instrument Panel Wire (Right Kick Panel) |
| II2 | | |
| IJ1 | 43 | Floor No.2 Wire and Instrument Panel Wire (Right Kick Panel) |

▽ : Ground Points

| Code | See Page | Ground Points Location |
|------|----------|------------------------|
| IF | 42 | Cowl Brace LH |
| IH | 42 | Cowl Brace RH |
| BI | 44 | Quarter Panel LH |

Wireless Door Lock Control

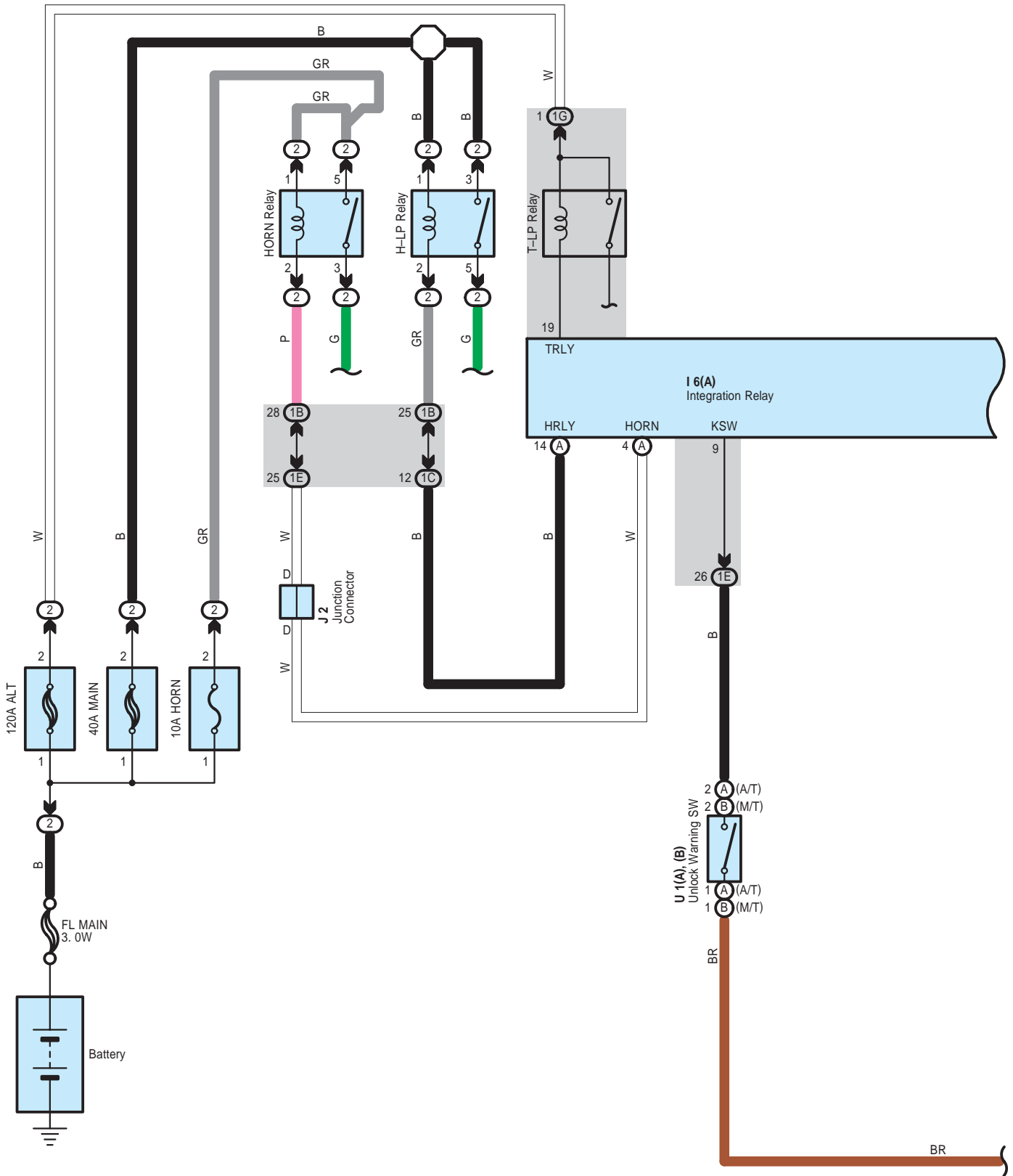

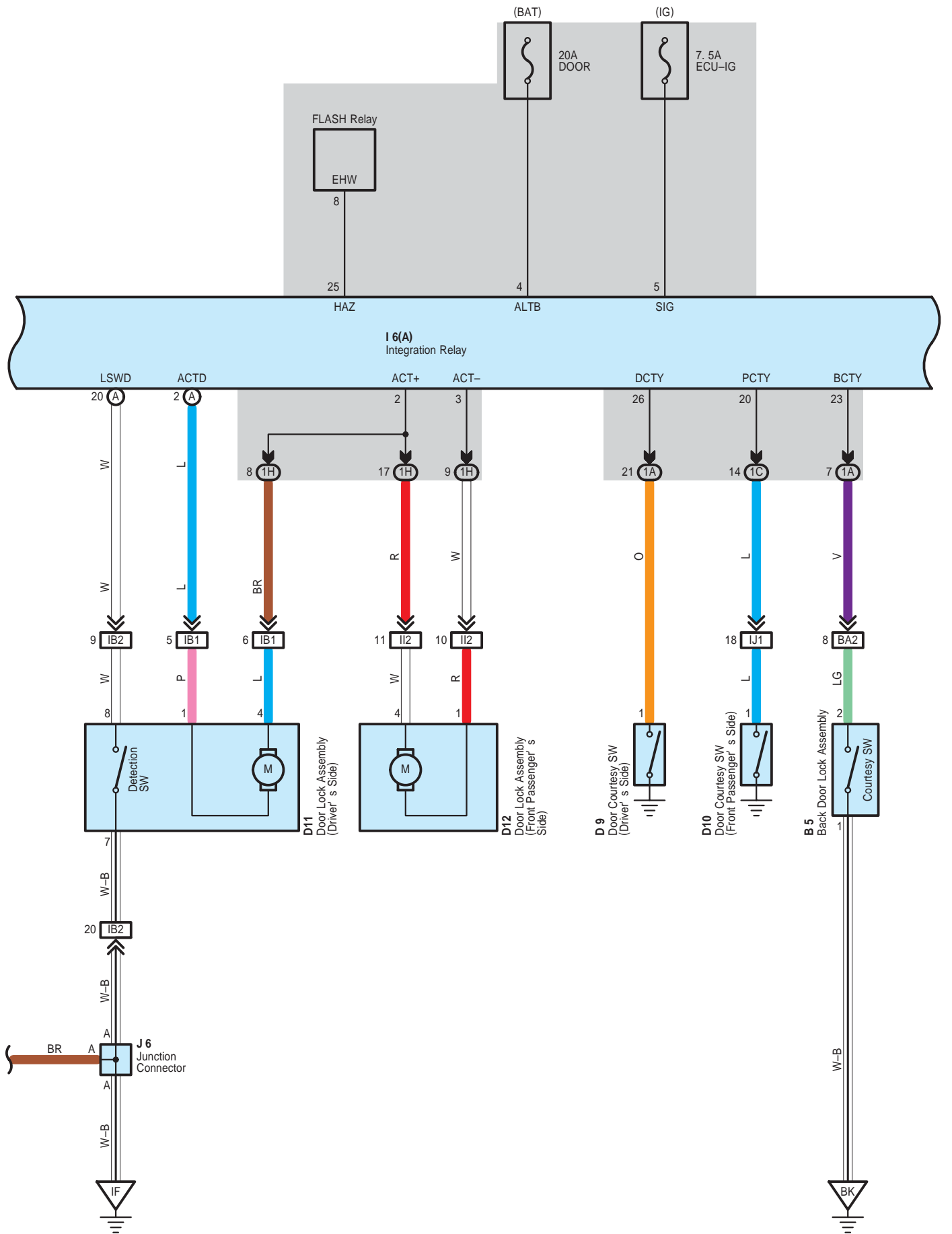

Wireless Door Lock Control

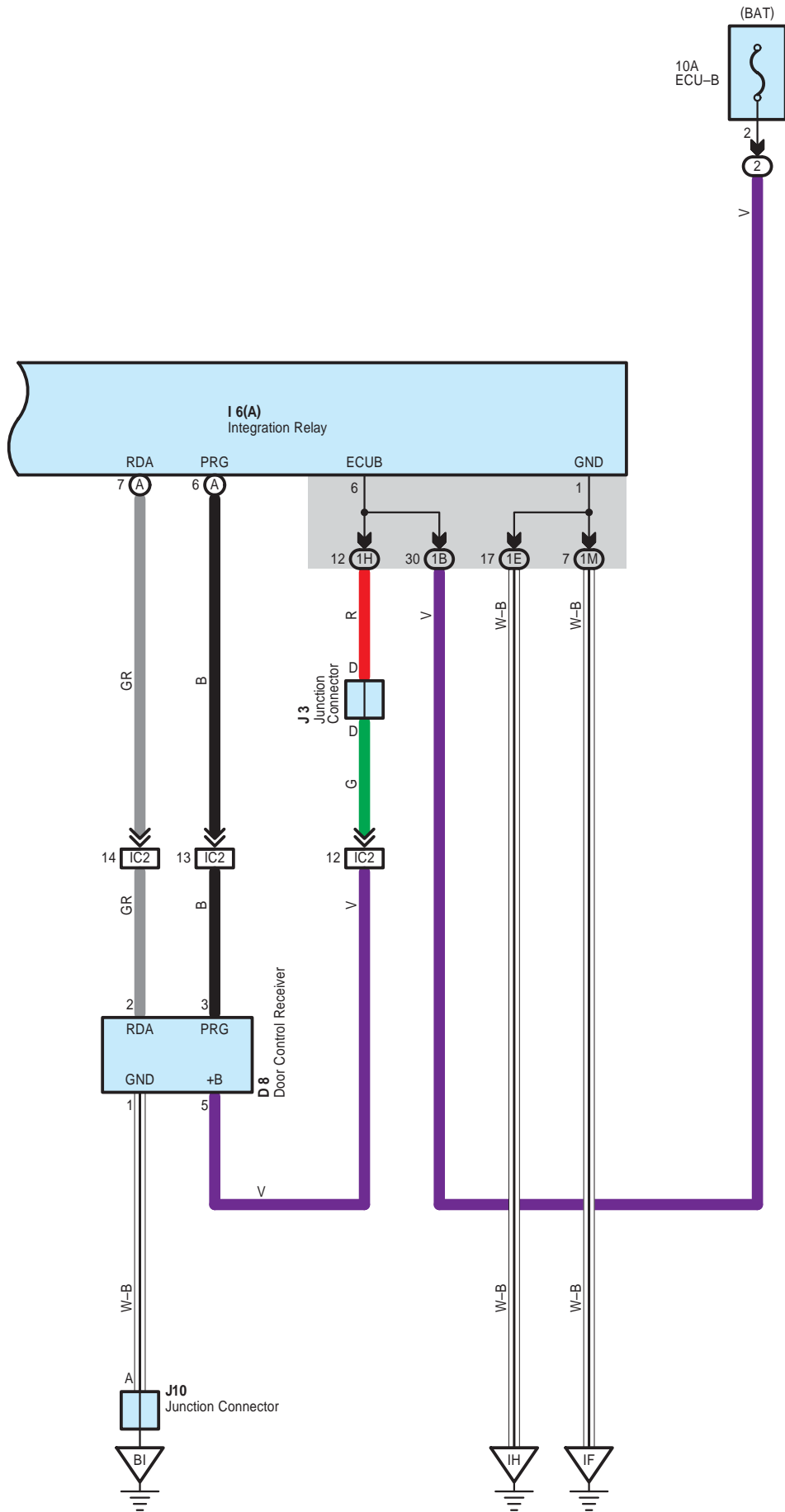

System Outline

Door lock control (Lock and unlock) and panic control (Theft alarm and flash) is performed by remote control, without the ignition key inserted in the door key cylinder, using low-power electrical waves emitted by a transmitter.

1. Normal Operation

* Lock operation

When the lock SW on the transmitter is pressed, all the doors are locked.

* Unlock operation

When the unlock SW on the transmitter is pressed once, only the driver door is unlocked. When the unlock SW is pressed again within 3 seconds, all the doors are unlocked.

2. Auto Lock Function

When the door is not actually opened within 30 seconds after the door has been unlocked by the unlock SW on the transmitter, all the doors are automatically locked. If any of the following conditions are detected, the wireless door lock does not function.

* Any door is opened.

* The ignition key is inserted into the ignition SW.

* When the lock detection SW of the door is locked.

3. Wireless Door Lock Stop Function

If any of the following conditions are detected, the wireless door lock does not function.

Lock operation

* When any door is open (Door courtesy SW on)

* The ignition key is inserted into the ignition SW (Unlock warning SW on)

* Ignition SW is on

Unlock operation

* Ignition SW is on

4. Visual Confirmation of Lock or Unlock

During lock operation, when the integration relay receives a lock signal from the door lock detection SW, the turn signal lamp is flashed once. During unlock operation, when the integration relay receives an unlock signal from the door lock detection SW, the turn signal lamp is flashed twice.

5. Remote Panic Operation

Panic will function when doors are locked or unlocked, open or closed. When the panic button (Transmitter) is pushed once, map lamp, room lamp (Center) and ignition key cylinder lamp light up, and theft alarm and horn sounds and turn signal lamp, headlamp and taillamp flash. Then, the panic, the lock or the unlock button (Transmitter) is pushed once more, map lamp, room lamp (Center) and ignition key cylinder lamp are turned off, sounding and flashing will stop. Panic will not function when ignition key is in ignition key cylinder.

6. Repeat Function

If the lock detection signal in response to the output signal is not received after the integration relay has output the lock signal, the lock signal is output again.

○ : Parts Location

| Code | See Page | Code | See Page | Code | See Page |
|------|----------|------|----------|------|----------|
| B5 | 38 | D12 | 38 | J10 | 38 |
| D8 | 38 | I6 | A | U1 | A |
| D9 | 38 | J2 | 37 | | B |
| D10 | 38 | J3 | 37 | | |
| D11 | 38 | J6 | 37 | | |

□ : Relay Blocks

| Code | See Page | Relay Blocks (Relay Block Location) |
|------|----------|---|
| 2 | 22 | Engine Room R/B (Engine Compartment Left) |

Wireless Door Lock Control

: Junction Block and Wire Harness Connector

| Code | See Page | Junction Block and Wire Harness (Connector Location) |
|------|----------|---|
| 1A | 24 | Floor Wire and Instrument Panel J/B (Lower Finish Panel) |
| 1B | 24 | Engine Room Main Wire and Instrument Panel J/B (Lower Finish Panel) |
| 1C | 24 | Instrument Panel Wire and Instrument Panel J/B (Lower Finish Panel) |
| 1E | | |
| 1G | 24 | Engine Room Main Wire and Instrument Panel J/B (Lower Finish Panel) |
| 1H | 24 | Instrument Panel Wire and Instrument Panel J/B (Lower Finish Panel) |
| 1M | 25 | |

: Connector Joining Wire Harness and Wire Harness

| Code | See Page | Joining Wire Harness and Wire Harness (Connector Location) |
|------|----------|---|
| IB1 | 42 | Front Door LH Wire and Instrument Panel Wire (Left Kick Panel) |
| IB2 | | |
| IC2 | 42 | Floor Wire and Instrument Panel Wire (Left Kick Panel) |
| II2 | 43 | Front Door RH Wire and Instrument Panel Wire (Right Kick Panel) |
| IJ1 | 43 | Floor No.2 Wire and Instrument Panel Wire (Right Kick Panel) |
| BA2 | 44 | Back Door No.1 Wire and Floor Wire (Back Window Upper Frame LH) |

: Ground Points

| Code | See Page | Ground Points Location |
|------|----------|----------------------------------|
| IF | 42 | Cowl Brace LH |
| IH | 42 | Cowl Brace RH |
| BI | 44 | Quarter Panel LH |
| BK | 44 | Left Side of the Back Door Panel |

Back Door Opener

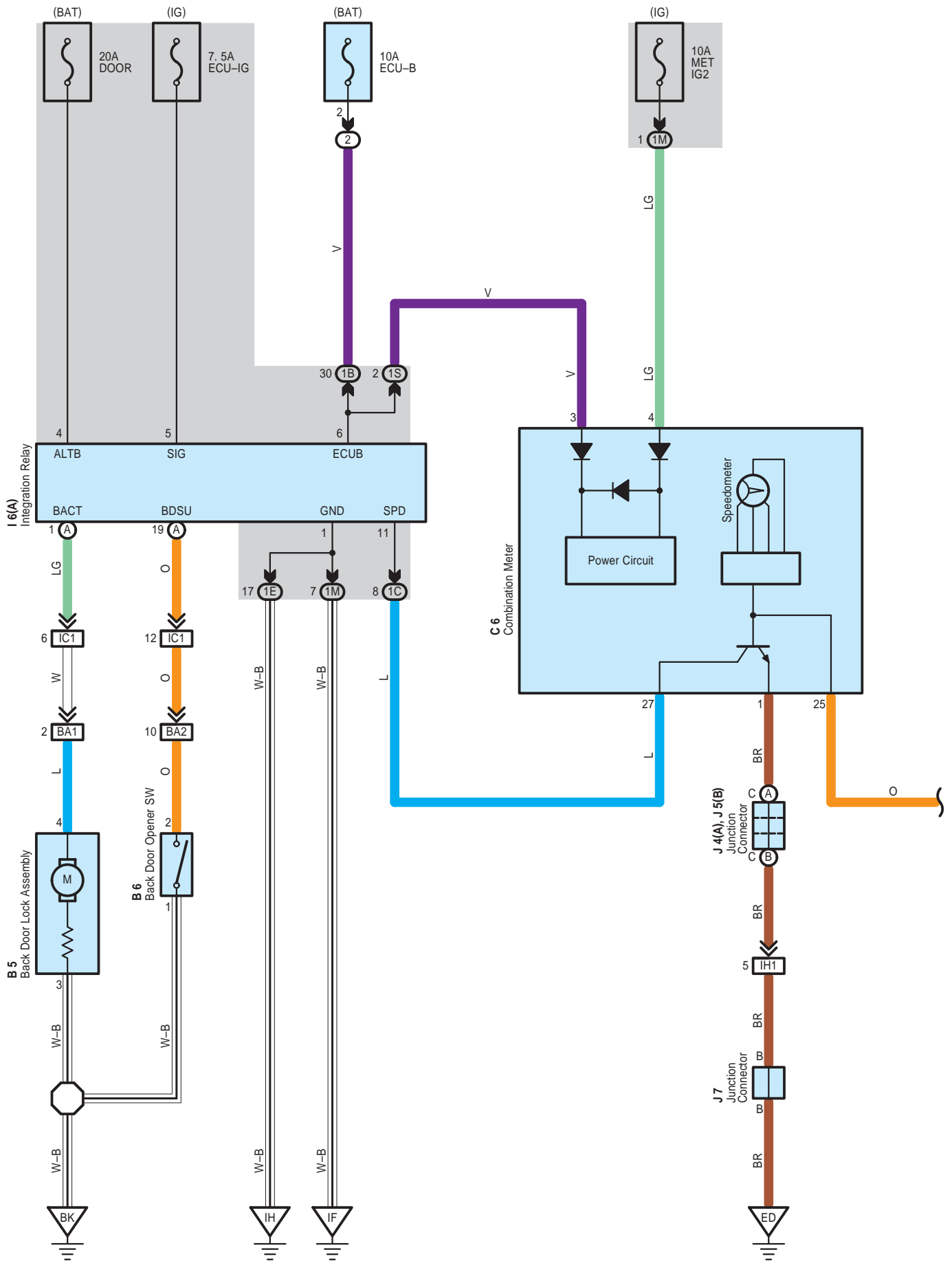

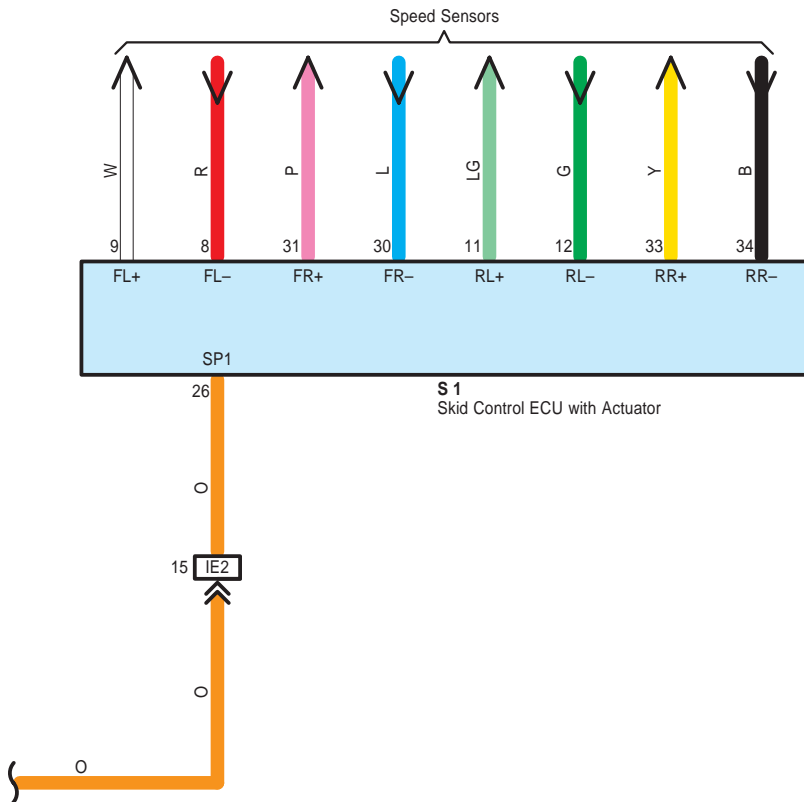

Back Door Opener

System Outline

If the vehicle is stationary (Slower than 5 km/h), the back door opener motor activates with control of integration relay when back door opener SW is pushed. It results in releasing latch of back door to open back door.

○ : Parts Location

| Code | See Page | Code | See Page | Code | See Page |
|------|----------|------|----------|------|----------|
| B5 | 38 | I6 | A 37 | J7 | 37 |
| B6 | 38 | J4 | A 37 | S1 | 35 |
| C6 | 36 | J5 | B 37 | | |

○ : Relay Blocks

| Code | See Page | Relay Blocks (Relay Block Location) |
|------|----------|---|
| 2 | 22 | Engine Room R/B (Engine Compartment Left) |

○ : Junction Block and Wire Harness Connector

| Code | See Page | Junction Block and Wire Harness (Connector Location) |
|------|----------|---|
| 1B | 24 | Engine Room Main Wire and Instrument Panel J/B (Lower Finish Panel) |
| 1C | 24 | Instrument Panel Wire and Instrument Panel J/B (Lower Finish Panel) |
| 1E | | |
| 1M | 25 | |
| 1S | | |

□ : Connector Joining Wire Harness and Wire Harness

| Code | See Page | Joining Wire Harness and Wire Harness (Connector Location) |
|------|----------|---|
| IC1 | 42 | Floor Wire and Instrument Panel Wire (Left Kick Panel) |
| IE2 | 42 | Engine Room Main Wire and Instrument Panel Wire (Behind of the Combination Meter) |
| IH1 | 43 | Engine Wire and Instrument Panel Wire (Cowl Side Panel RH) |
| BA1 | 44 | Back Door No.1 Wire and Floor Wire (Back Window Upper Frame LH) |
| BA2 | | |

▽ : Ground Points

| Code | See Page | Ground Points Location |
|------|----------|--------------------------------------|
| ED | 40 | Front Left Side of the Cylinder Head |
| IF | 42 | Cowl Brace LH |
| IH | 42 | Cowl Brace RH |
| BK | 44 | Left Side of the Back Door Panel |

Sliding Roof

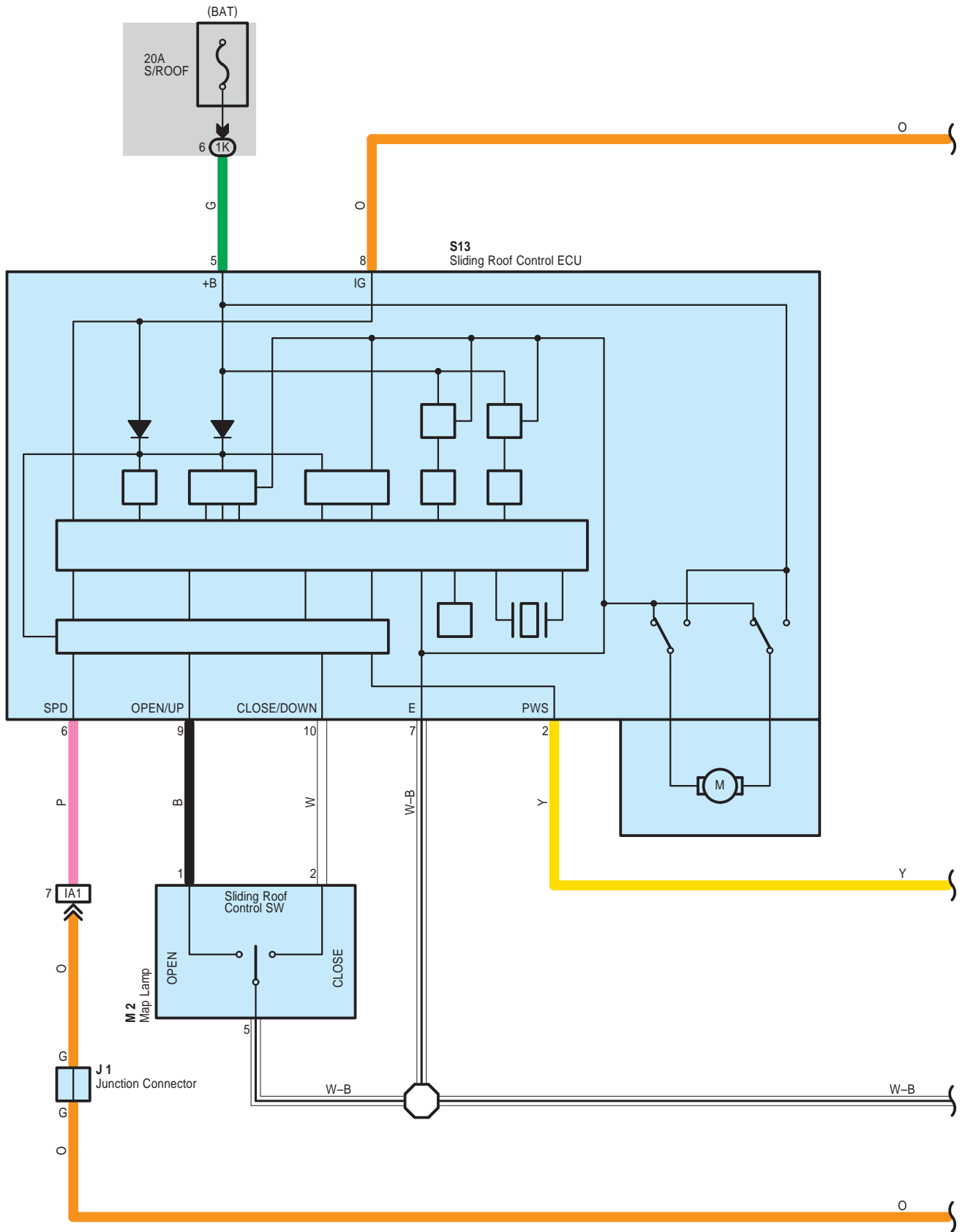

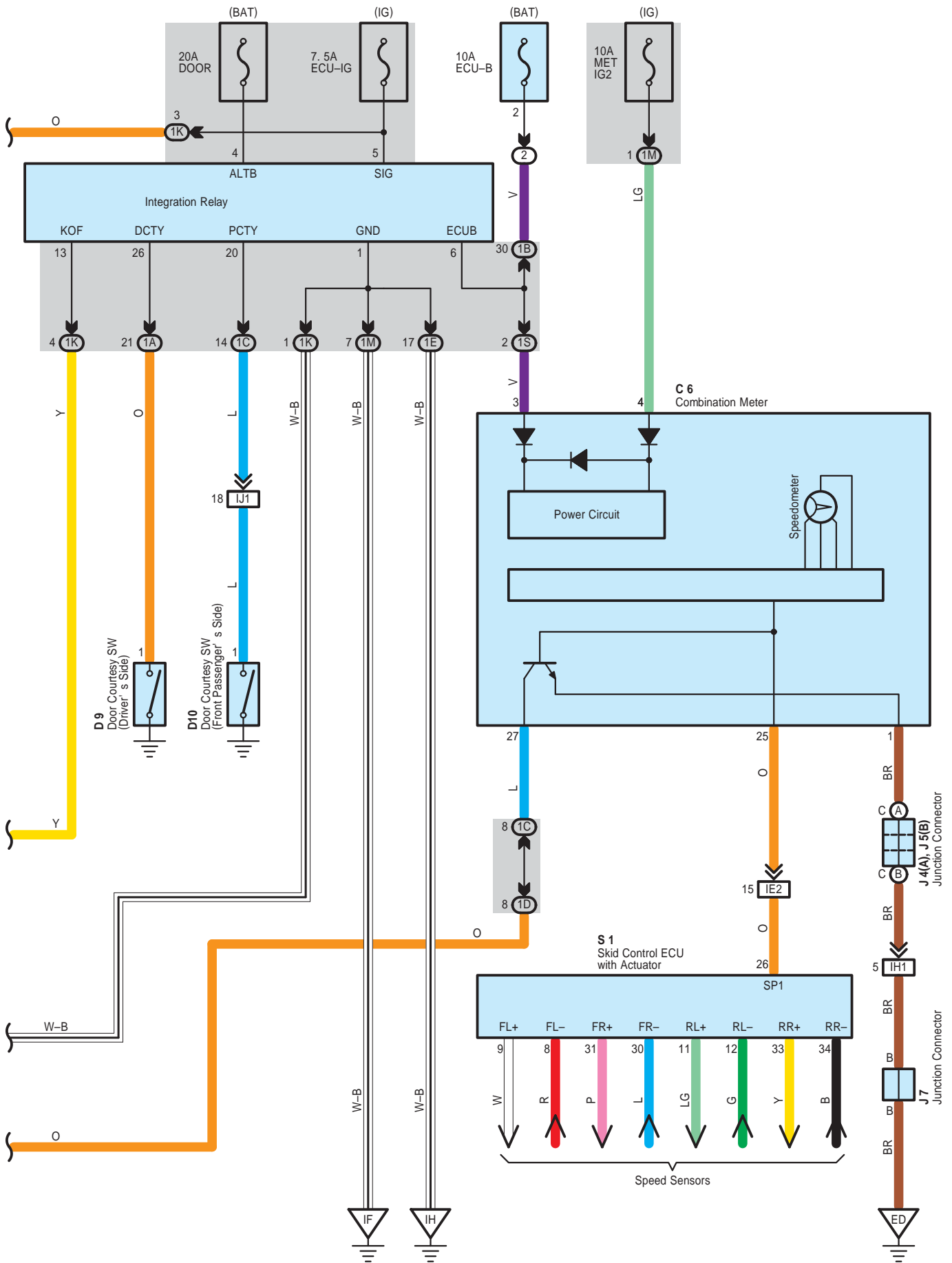

Sliding Roof

System Outline

Current is always applied from the S/ROOF fuse to TERMINAL 5 of the sliding roof control ECU. With the ignition SW turned on, the current from the ECU-IG fuse flows to TERMINAL 8 of the sliding roof control ECU.

1. Sliding Roof Open/Close Operation

For sliding roof operation, there are sliding roof control switches: "Slide open/tilt up"; and "Slide close/tilt down." When a switch is pressed and held down for a certain period of time, one touch automatic operation takes place in accordance with the function of the switch.

2. Key-Off Operation

Roof remains operable – until about 43 seconds elapse after the ignition SW is turned from ON to OFF or until the driver's or passenger's door is opened, whichever first occurs.

However, if an overload reverse operation was going on at that time, the key-off operation continues until it comes to an end.

3. Overload Reverse Operation

The sliding roof control ECU detects jamming of the sliding roof by foreign material, if occurred, from abnormal motor speed signal and reverses the sliding roof operation.

* When the battery terminal or fuse is disconnected, the roof position has to be reset to its initial position by the sliding roof control SW in accordance with the following procedure:

- (1) Reconnect the battery terminal or fuse.
- (2) Turn ON the ignition switch.
- (3) Operate the sliding roof control SW to open the roof halfway or more.
- (4) Then operate the sliding roof control SW to fully close the roof.
Do not release the switch for at least 2 seconds after the roof is fully closed.

: Parts Location

| Code | See Page | Code | See Page | Code | See Page | |
|------|----------|------|----------|------|----------|----|
| C6 | 36 | J4 | A | 37 | S1 | 35 |
| D9 | 38 | J5 | B | 37 | S13 | 39 |
| D10 | 38 | J7 | | 37 | | |
| J1 | 37 | M2 | | 38 | | |

: Relay Blocks

| Code | See Page | Relay Blocks (Relay Block Location) |
|------|----------|---|
| 2 | 22 | Engine Room R/B (Engine Compartment Left) |

: Junction Block and Wire Harness Connector

| Code | See Page | Junction Block and Wire Harness (Connector Location) |
|------|----------|---|
| 1A | 24 | Floor Wire and Instrument Panel J/B (Lower Finish Panel) |
| 1B | 24 | Engine Room Main Wire and Instrument Panel J/B (Lower Finish Panel) |
| 1C | 24 | Instrument Panel Wire and Instrument Panel J/B (Lower Finish Panel) |
| 1D | | |
| 1E | | |
| 1K | 24 | Roof Wire and Instrument Panel J/B (Lower Finish Panel) |
| 1M | 25 | Instrument Panel Wire and Instrument Panel J/B (Lower Finish Panel) |
| 1S | | |

: Connector Joining Wire Harness and Wire Harness

| Code | See Page | Joining Wire Harness and Wire Harness (Connector Location) |
|------|----------|---|
| IA1 | 42 | Roof Wire and Instrument Panel Wire (Cowl Top Side Panel LH) |
| IE2 | 42 | Engine Room Main Wire and Instrument Panel Wire (Behind of the Combination Meter) |
| IH1 | 43 | Engine Wire and Instrument Panel Wire (Cowl Side Panel RH) |
| IJ1 | 43 | Floor No.2 Wire and Instrument Panel Wire (Right Kick Panel) |



: Ground Points

| Code | See Page | Ground Points Location |
|------|----------|--------------------------------------|
| ED | 40 | Front Left Side of the Cylinder Head |
| IF | 42 | Cowl Brace LH |
| IH | 42 | Cowl Brace RH |

Shift Lock

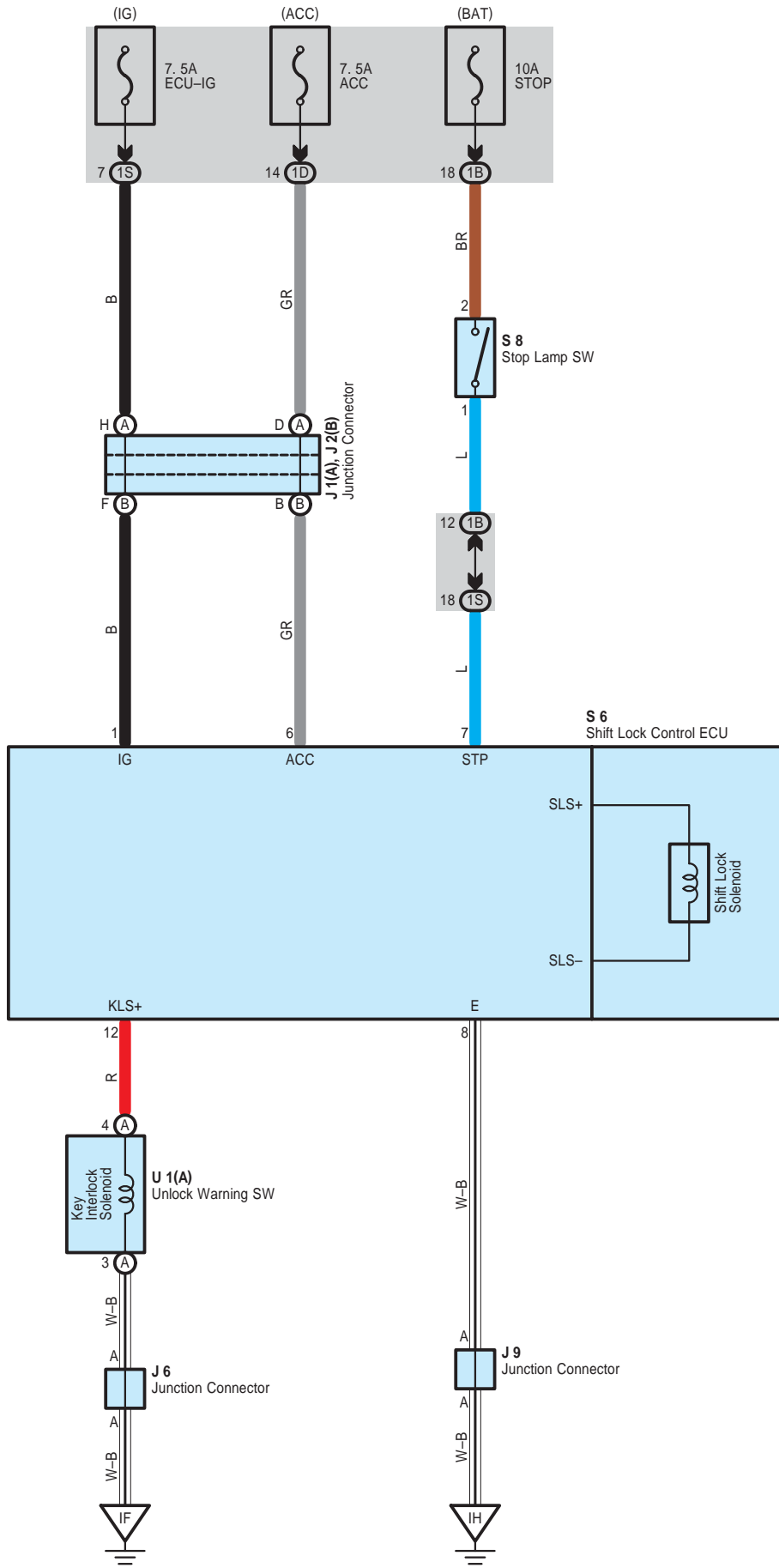

System Outline

When the ignition SW is turned to ACC position the current from the ACC fuse flows to TERMINAL 6 of the shift lock control ECU. When the ignition SW is turned to ON position, the current from the ECU-IG fuse flows to TERMINAL 1 of the shift lock control ECU.

1. Shift Lock Mechanism

If the brake pedal is depressed with the ignition SW set at ON (The stop light SW is on), the shift lock control ECU is activated, allowing the driver to change the shift lever to a position other than the P position.

2. Key Interlock Mechanism

With the ignition SW at ON or ACC position, when the shift lever is put in P position, the current flowing from TERMINAL 12 of the shift lock control ECU to key interlock solenoid is cut off. This causes the key interlock solenoid to turn off (Lock lever disengages from LOCK position) and the ignition key can be turned from ACC to LOCK position.

○ : Parts Location

| Code | | See Page | Code | | See Page | Code | | See Page |
|------|---|----------|------|----|----------|------|----|----------|
| J1 | A | 37 | J9 | 37 | U1 | A | 37 | |
| J2 | B | 37 | S6 | 37 | | | | |
| J6 | | 37 | S8 | 37 | | | | |

○ : Junction Block and Wire Harness Connector

| Code | See Page | Junction Block and Wire Harness (Connector Location) |
|------|----------|---|
| 1B | 24 | Engine Room Main Wire and Instrument Panel J/B (Lower Finish Panel) |
| 1D | 24 | Instrument Panel Wire and Instrument Panel J/B (Lower Finish Panel) |
| 1S | 25 | |

▽ : Ground Points

| Code | See Page | Ground Points Location |
|------|----------|------------------------|
| IF | 42 | Cowl Brace LH |
| IH | 42 | Cowl Brace RH |

ECT and A/T Indicator

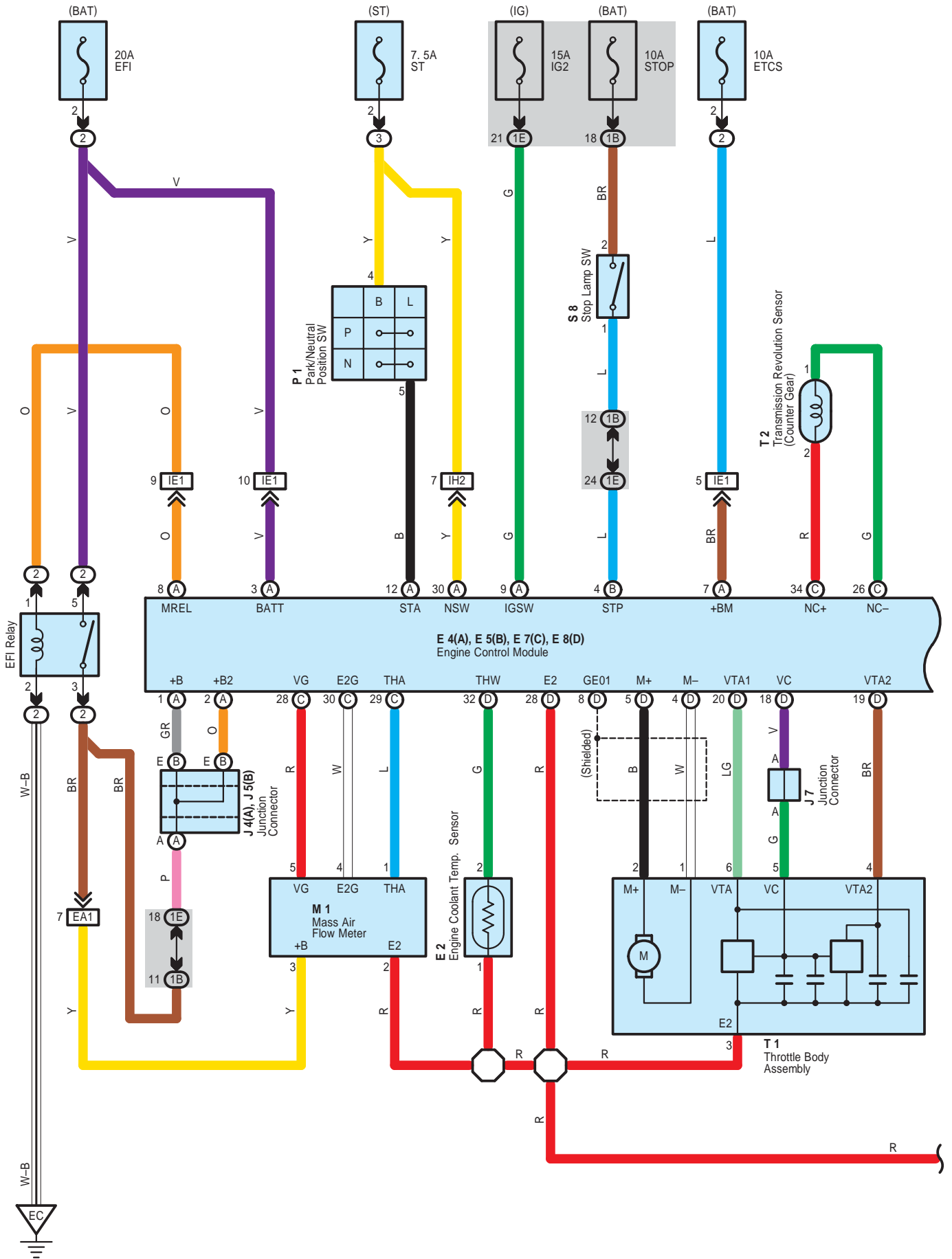

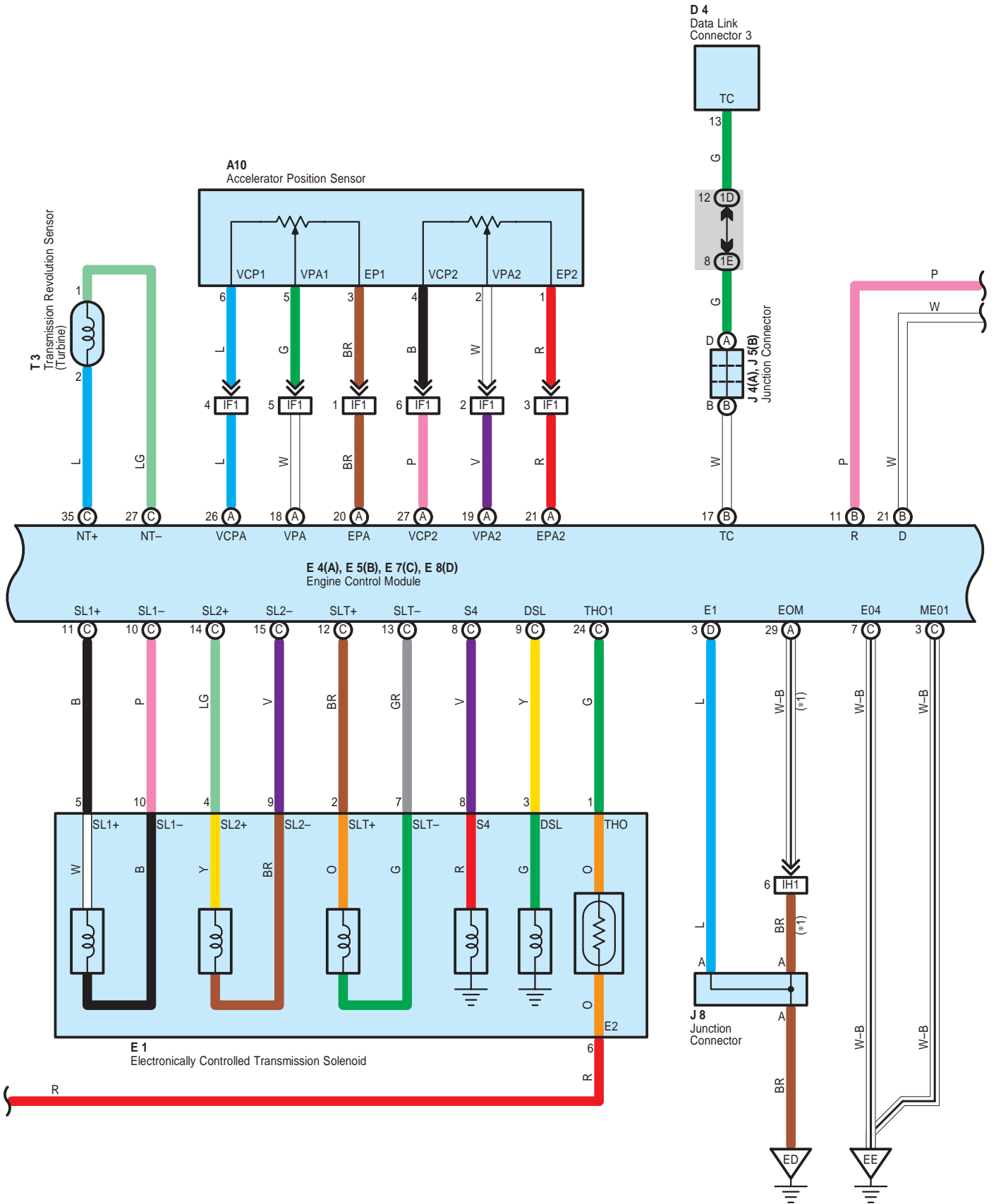

ECT and A/T Indicator

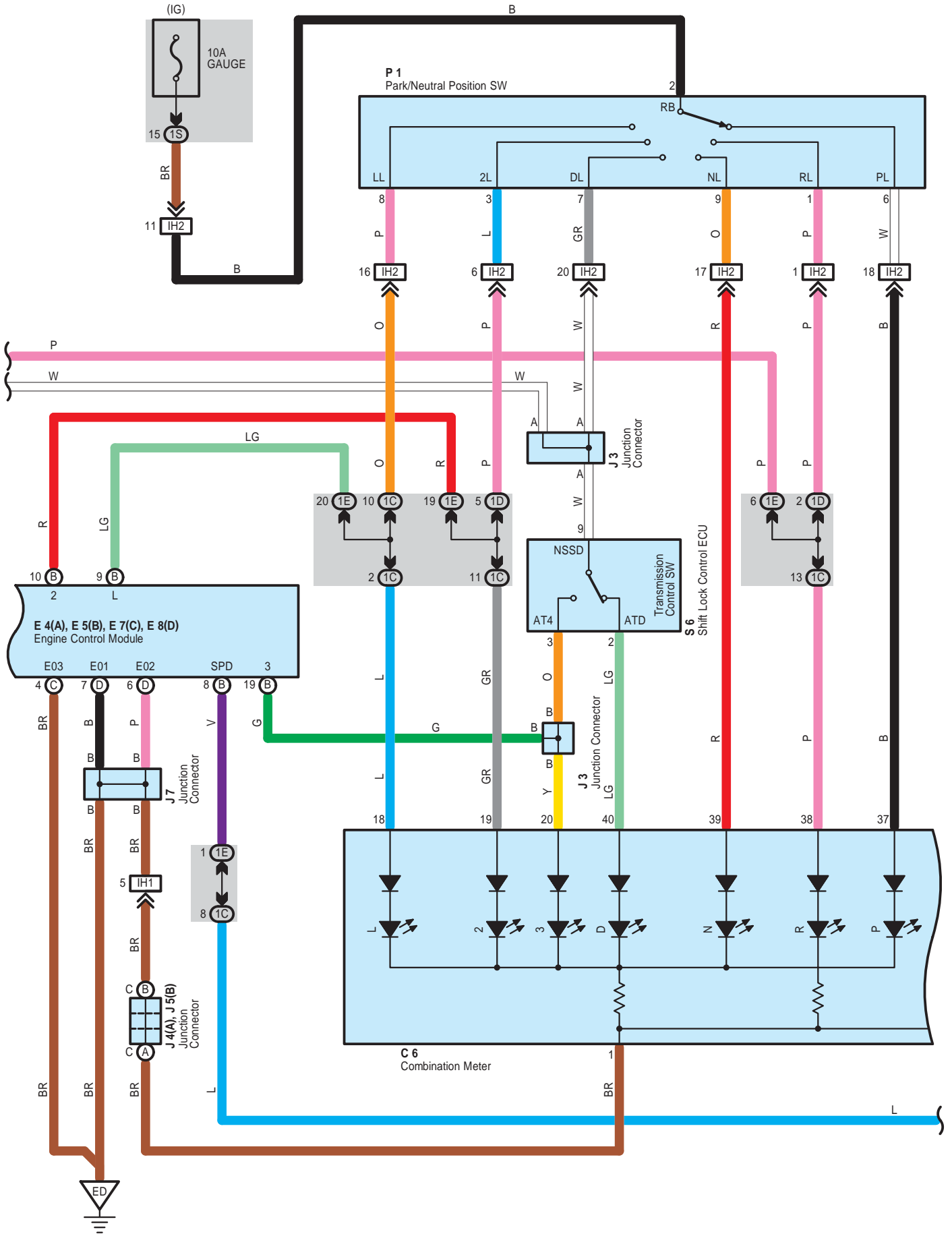

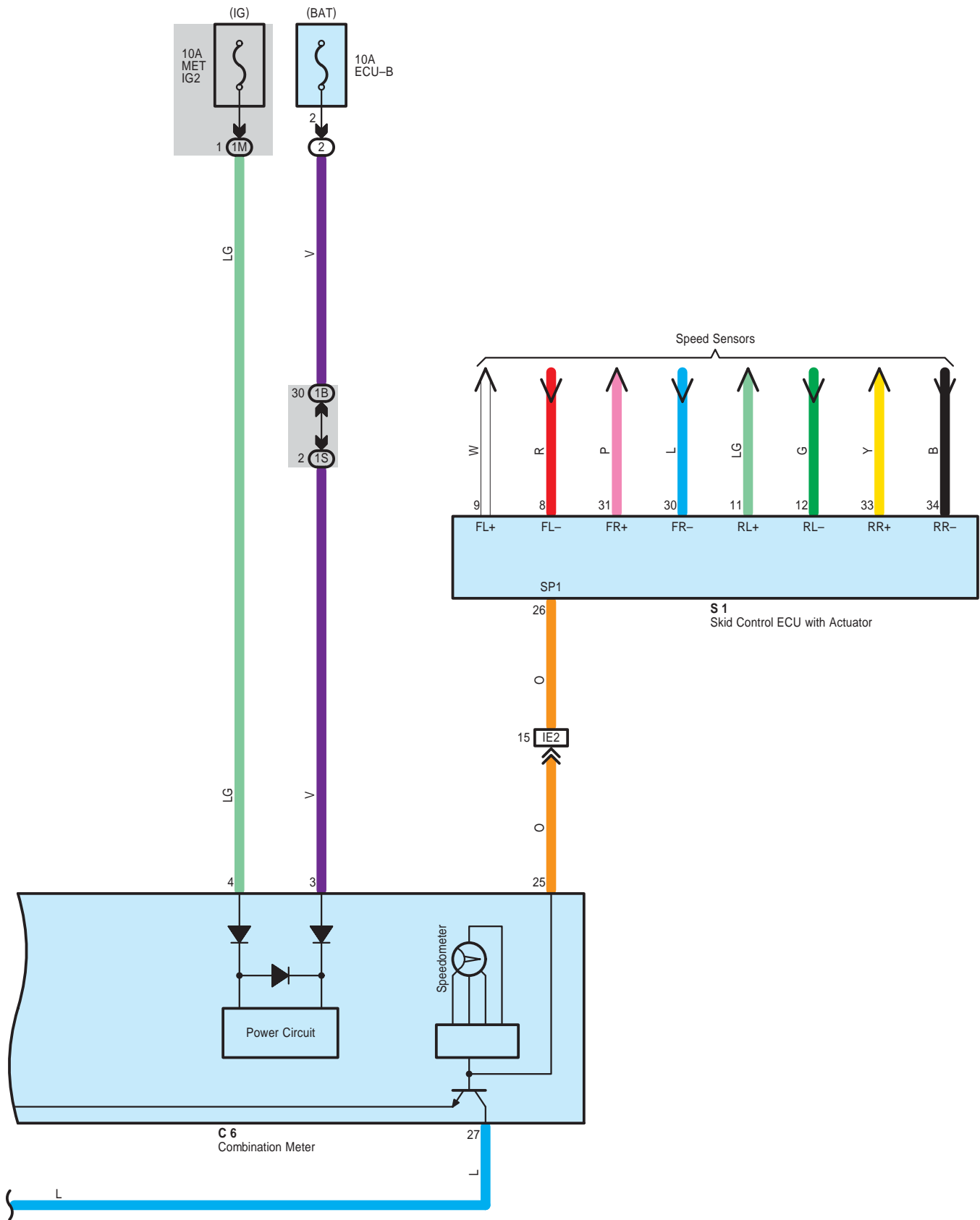

ECT and A/T Indicator

System Outline

Previous automatic transaxle have selected each gear shift using the mechanically controlled throttle hydraulic pressure, governor hydraulic pressure and lock-up hydraulic pressure. The electronically controlled transmission, however, electrically controls the line pressure and lock-up pressure etc., through the solenoid valve. Engine control module controls each solenoid valve based on the input signals from each sensor, which makes smooth driving possible by shift selection for each gear that is most appropriate to the driving conditions at that time.

1. Gear Shift Operation

When driving, the engine warm up condition is input as a signal to TERMINAL THW of the engine control module from the engine coolant temp. sensor and the vehicle speed signal is input to TERMINAL SPD of the engine control module. At the same time, the throttle valve opening signal from throttle body assembly is input to TERMINALS VTA1 and VTA2 of the engine control module as throttle angle signal.

Based on these signals, the engine control module selects the best shift position for the driving conditions and sends current to the electronically controlled transmission solenoid.

2. Lock-Up Operation

When the engine control module judges from each signal that lock-up operation conditions have been met, current flows from TERMINAL S4 of the engine control module to TERMINAL 8 of the electronically controlled transmission solenoid to GROUND, causing continuity to the lock-up solenoid and causing lock-up operation.

3. Clutch Pressure Control

The electronically controlled transmission solenoid is controlled by the current from TERMINAL SLT+ of the engine control module, and controls the accumulator hydraulic pressure.

As a result, the clutch to hydraulic pressure is adjusted precisely, and allows stable shift change.

4. Line Pressure Control

The engine control module adjusts the line hydraulic pressure to the optimal level by controlling TERMINAL SLT+ of the module according to the engine torque data. This realizes the smooth gear shifting.

5. Shifting Control in Uphill/Downhill Traveling

This system determines whether the vehicle is traveling on an incline or decline from the throttle opening angle, vehicle acceleration condition and brake pedal operation, and controls the shift up to O/D to allow smooth driving.

6. Clutch to Clutch Control

When shifting from the 1st gear to the 2nd gear and the 2nd gear to the 3rd gear, the current from the engine control module TERMINALS SL1+ and SL2+ control the electronically controlled transmission solenoid, to control the drain orifice hydraulic pressure (Switch orifice). The electronically controlled transmission solenoid is also controlled by the current from the engine control module TERMINALS SL1+ and SL2+, to adjust the hydraulic pressure precisely, which ensures smooth shifting.

7. Stop Lamp SW Circuit

If the brake pedal is depressed (Stop lamp SW on) when driving in lock-up condition, a signal is input to TERMINAL STP of the engine control module, the engine control module operates and continuity to the lock-up solenoid is cut.

○ : Parts Location

| Code | See Page | Code | See Page | Code | See Page |
|--------|----------|--------|----------|------|----------|
| A10 | 36 | E8 D | 36 | S1 | 35 |
| C6 | 36 | J3 | 37 | S6 | 37 |
| D4 | 36 | J4 A | 37 | S8 | 37 |
| E1 | 34 | J5 B | 37 | T1 | 35 |
| E2 | 34 | J7 | 37 | T2 | 35 |
| E4 A | 36 | J8 | 37 | T3 | 35 |
| E5 B | 36 | M1 | 35 | | |
| E7 C | 36 | P1 | 35 | | |

○ : Relay Blocks

| Code | See Page | Relay Blocks (Relay Block Location) |
|------|----------|--|
| 2 | 22 | Engine Room R/B (Engine Compartment Left) |
| 3 | 23 | Engine Room R/B No.2 (Inside of the Engine Room R/B Box) |

 : **Junction Block and Wire Harness Connector**

| Code | See Page | Junction Block and Wire Harness (Connector Location) |
|------|----------|---|
| 1B | 24 | Engine Room Main Wire and Instrument Panel J/B (Lower Finish Panel) |
| 1C | 24 | Instrument Panel Wire and Instrument Panel J/B (Lower Finish Panel) |
| 1D | | |
| 1E | | |
| 1M | 25 | |
| 1S | | |

 : **Connector Joining Wire Harness and Wire Harness**

| Code | See Page | Joining Wire Harness and Wire Harness (Connector Location) |
|------|----------|---|
| EA1 | 40 | Engine Wire and Engine Room Main Wire (Inside of the Engine Room R/B Box) |
| IE1 | 42 | Engine Room Main Wire and Instrument Panel Wire (Behind of the Combination Meter) |
| IE2 | | |
| IF1 | 43 | Instrument Panel Wire and Sensor Wire (Instrument Panel Brace LH) |
| IH1 | 43 | Engine Wire and Instrument Panel Wire (Cowl Side Panel RH) |
| IH2 | | |

 : **Ground Points**

| Code | See Page | Ground Points Location |
|------|----------|--------------------------------------|
| EC | 40 | Front Left Fender |
| ED | 40 | Front Left Side of the Cylinder Head |
| EE | 40 | Left Side of the Cylinder Head |

Cruise Control

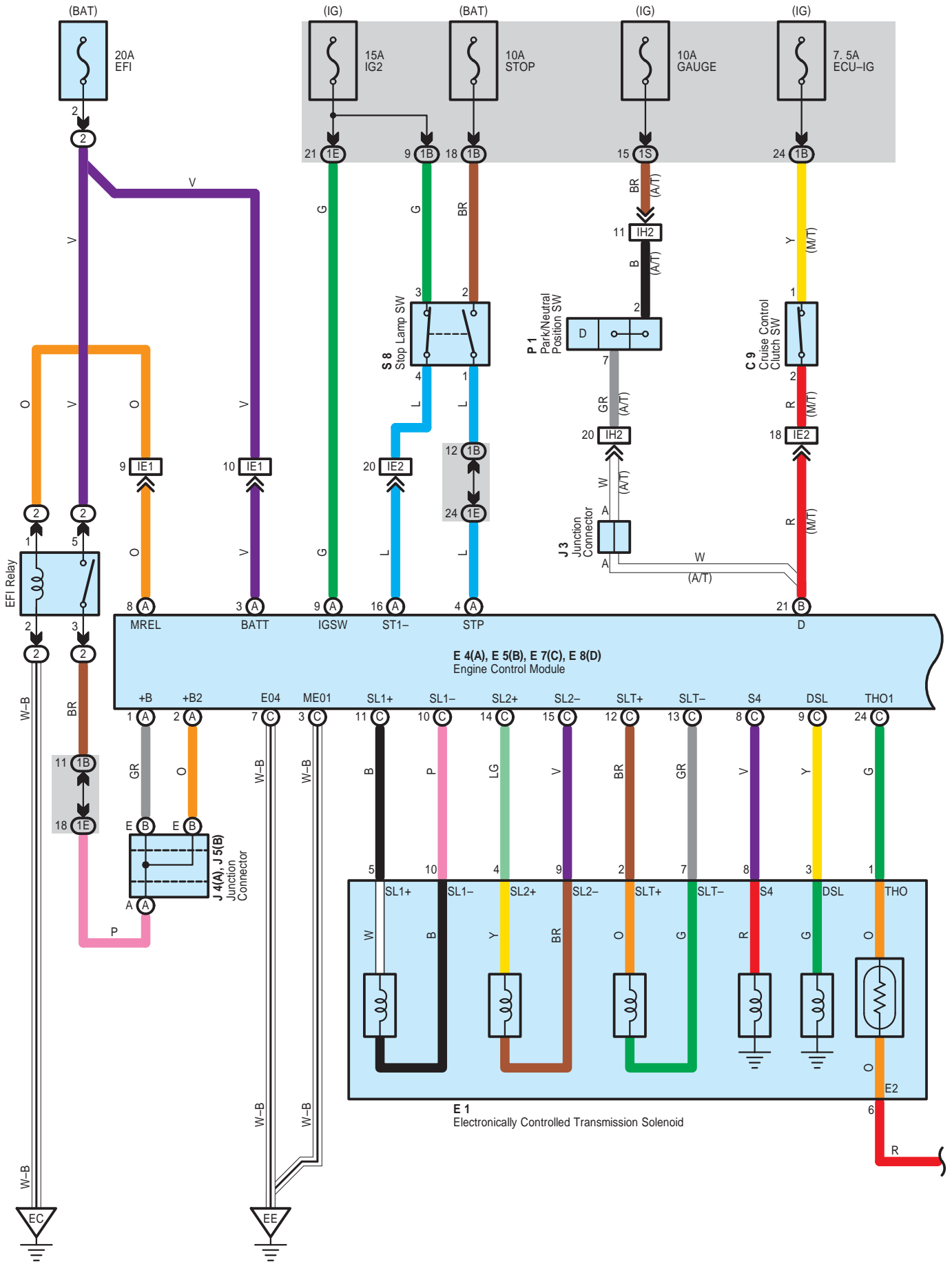

Cruise Control

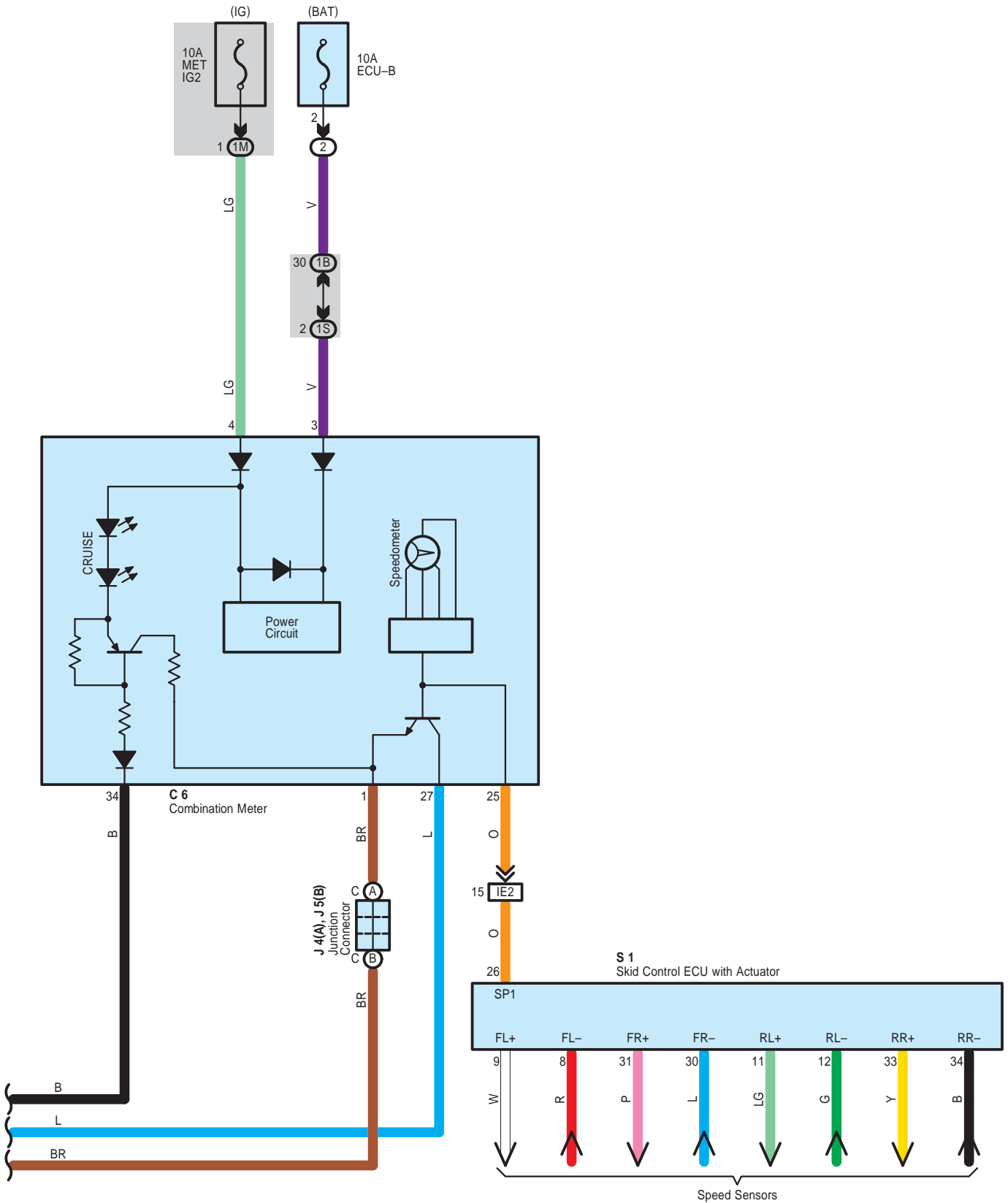

System Outline

The cruise control system is a constant vehicle speed controller in which control of the switch on the steering wheel makes it possible to automatically adjust the opening of the engine throttle valve without depressing of the accel pedal.

1. Set Operation

When the ON-OFF SW is turned on, the system starts preparations necessary for the cruise control and turns on the indicator light in the combination meter.

2. Set Speed Control

When the SET/- SW is operated with the ON-OFF SW turned on during travelling, the constant vehicle speed is controlled.

3. Coast Control

When the SET/- SW is kept turned on during cruise control travelling, the engine control module controls the throttle valve to decelerate the vehicle. Every time the SET/- SW is turned on momentarily, the vehicle speed is decelerated by approximately 1.6 km/h. However, in the case of tap-down operation to make more than a 5 km/h difference between the set speed and the actual vehicle speed, the device memories the speed when the switch was turned off and controls it at that speed constantly.

4. Accel Control

When the RES/+ SW is kept turned on during cruise control travelling, the engine control module controls the throttle valve to accelerate the vehicle. Every time the RES/+ SW is turned on momentarily, the vehicle speed is accelerated by approximately 1.6 km/h. However, in the case of tap-up operation to make more than a 5 km/h difference between the set speed and the actual vehicle speed, the device does not change the set speed. (Tap-up operation is not available.)

5. Resume Control

When the vehicle speed falls below the low speed limit and the cruise control is cancelled, the preset speed is retained in the memory. However, the resume control is available only when the vehicle speed exceeds the low speed limit.

6. Manual Cancel Mechanism

If any of the following signals is input during cruise control travelling, the cruise control is cancelled.

- * The stop lamp SW is turned on. (The brake pedal is depressed)
- * The CANCEL SW is turned on.
- * The ON-OFF SW is turned off.
- * The cruise control clutch SW is turned off. (M/T) (The clutch pedal is depressed)
- * Gear is shifted from position D or 3 to other positions. (A/T)

7. Auto Cancel Function

If any of the following conditions is encountered, the cruise control is automatically cancelled.

- * Disconnection and/or short in the stop light SW
- * Malfunction in the vehicle speed signal
- * Malfunction in the electronic throttle parts
- * Malfunction in the stop lamp SW input circuit
- * Malfunction in the cancel circuit
- * The actual vehicle speed becomes slower than the minimum speed limit
- * The actual vehicle speed becomes 16 km/h slower than the set speed

8. Overdrive Control Function

The overdrive is sometimes cut off on hills during cruise control driving. When the end of a climbing hills is determined by the throttle opening degree information after the overdrive has been canceled, control is reset to the overdrive condition after the overdrive resetting timer operation. Also, when the overdrive is cut off during accelerator control and resuming control, control is reset to the overdrive condition when the accelerator control and resuming control is finished.

○ : Parts Location

| Code | See Page | Code | See Page | Code | See Page | |
|------|----------|------|----------|------|----------|----|
| C6 | 36 | E7 | C | 36 | J8 | 37 |
| C9 | 36 | E8 | D | 36 | P1 | 35 |
| D4 | 36 | J3 | | 37 | S1 | 35 |
| E1 | 34 | J4 | A | 37 | S7 | 37 |
| E4 | A | J5 | B | 37 | S8 | 37 |
| E5 | B | J7 | | 37 | T1 | 35 |

○ : Relay Blocks

| Code | See Page | Relay Blocks (Relay Block Location) |
|------|----------|---|
| 2 | 22 | Engine Room R/B (Engine Compartment Left) |

Cruise Control

: Junction Block and Wire Harness Connector

| Code | See Page | Junction Block and Wire Harness (Connector Location) |
|------|----------|---|
| 1B | 24 | Engine Room Main Wire and Instrument Panel J/B (Lower Finish Panel) |
| 1C | 24 | Instrument Panel Wire and Instrument Panel J/B (Lower Finish Panel) |
| 1D | | |
| 1E | | |
| 1M | 25 | |
| 1S | | |

: Connector Joining Wire Harness and Wire Harness

| Code | See Page | Joining Wire Harness and Wire Harness (Connector Location) |
|------|----------|---|
| IE1 | 42 | Engine Room Main Wire and Instrument Panel Wire (Behind of the Combination Meter) |
| IE2 | | |
| IH1 | 43 | Engine Wire and Instrument Panel Wire (Cowl Side Panel RH) |
| IH2 | | |

: Ground Points

| Code | See Page | Ground Points Location |
|------|----------|--------------------------------------|
| EC | 40 | Front Left Fender |
| ED | 40 | Front Left Side of the Cylinder Head |
| EE | 40 | Left Side of the Cylinder Head |

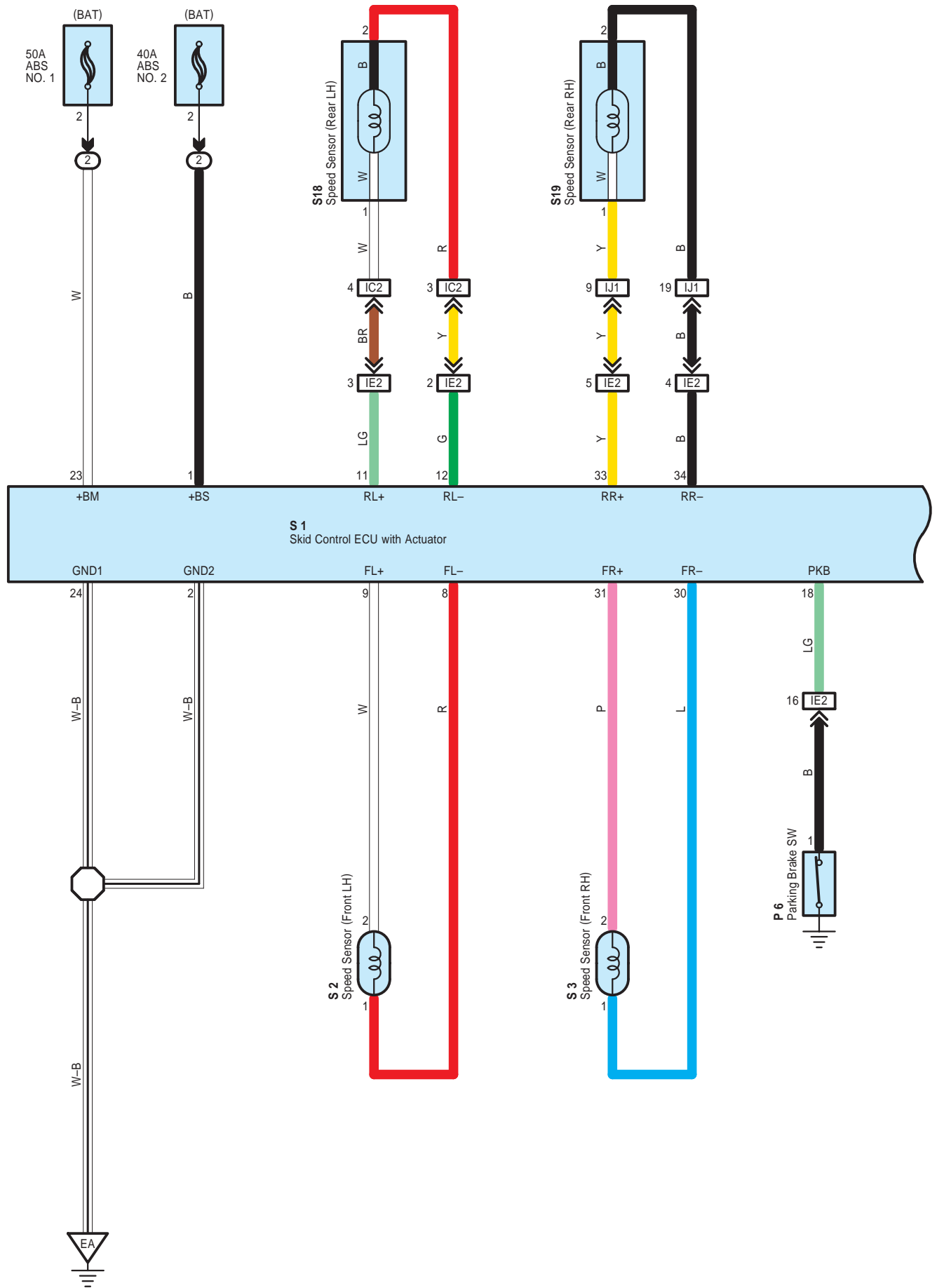

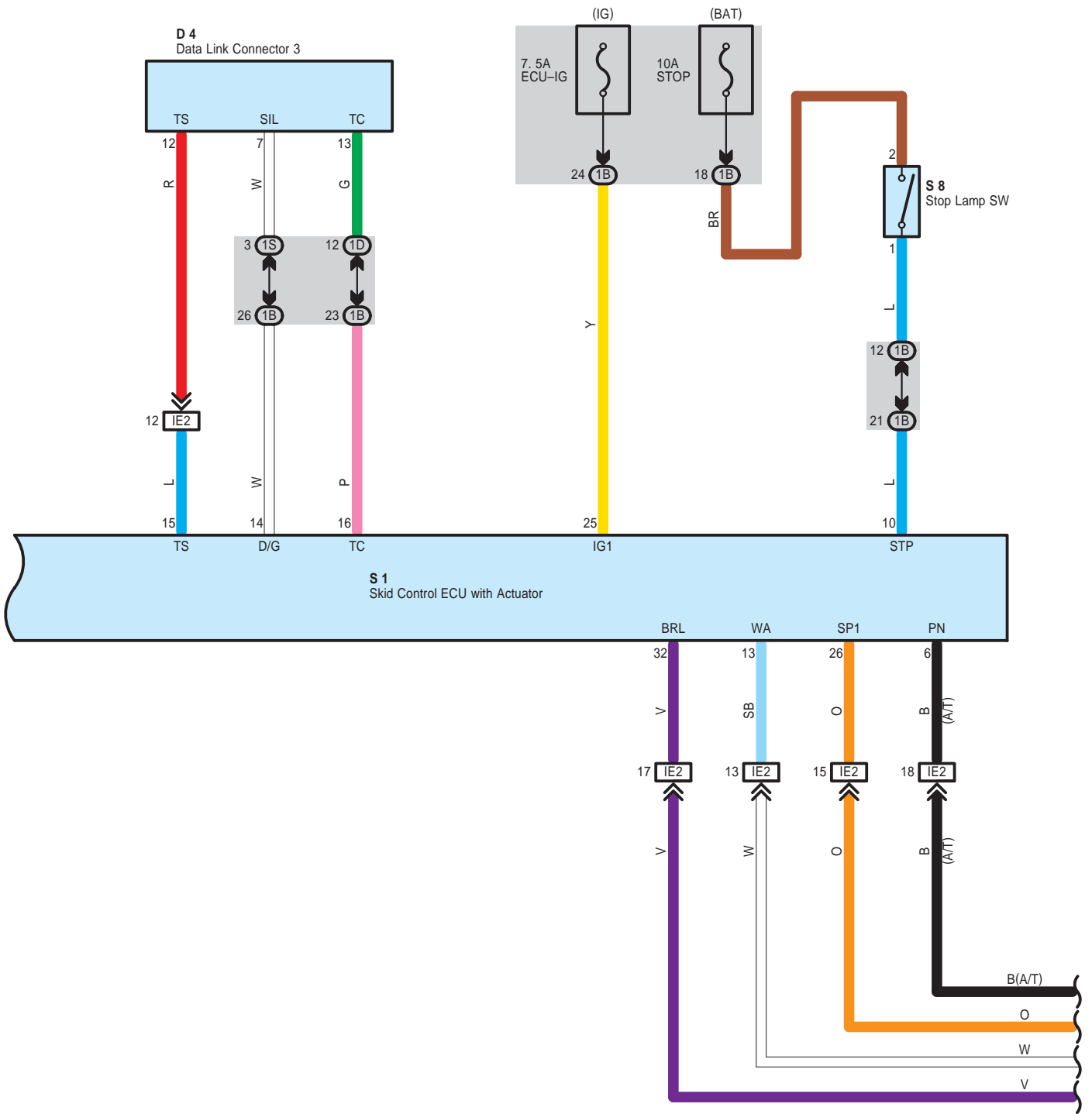

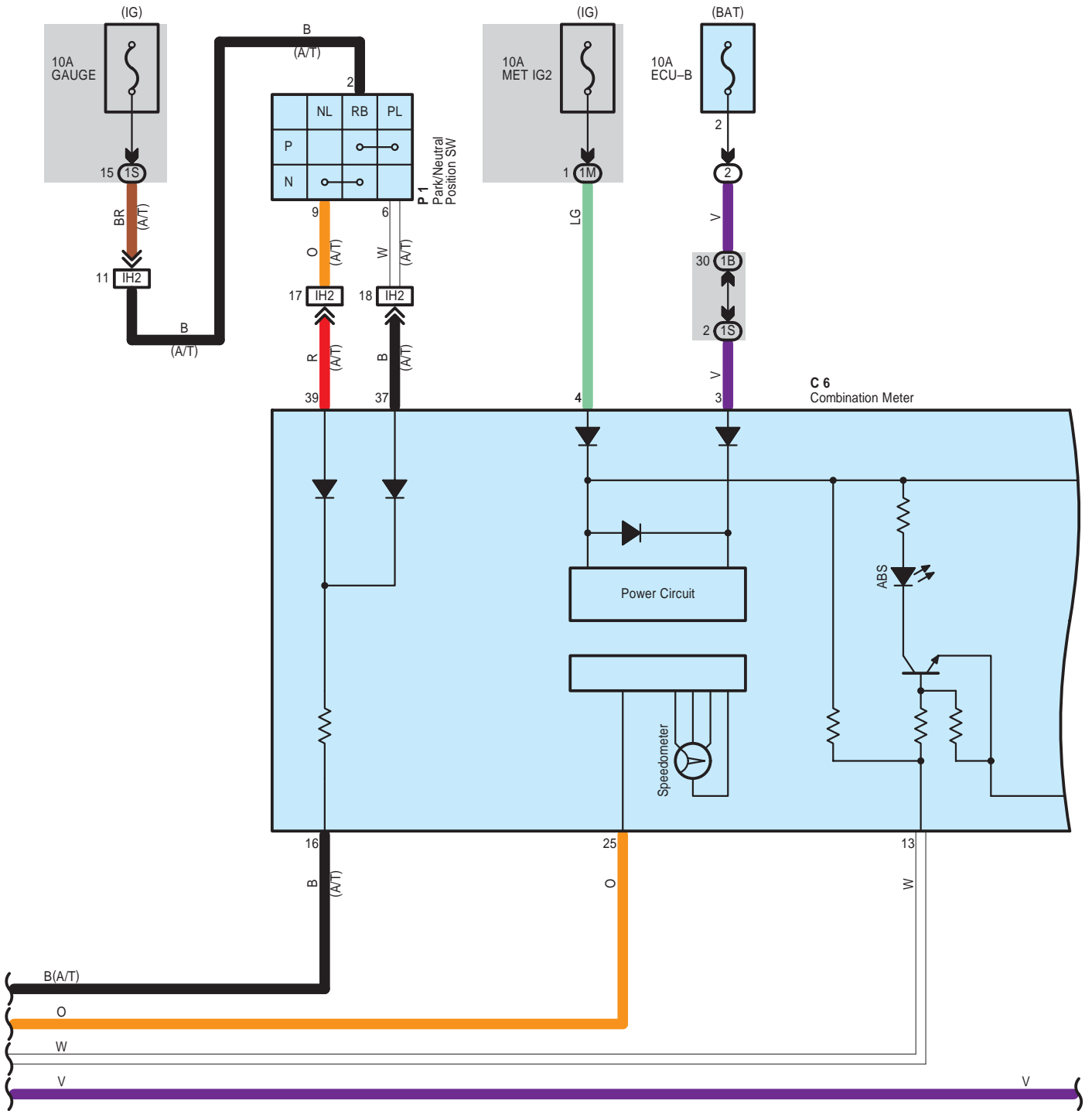

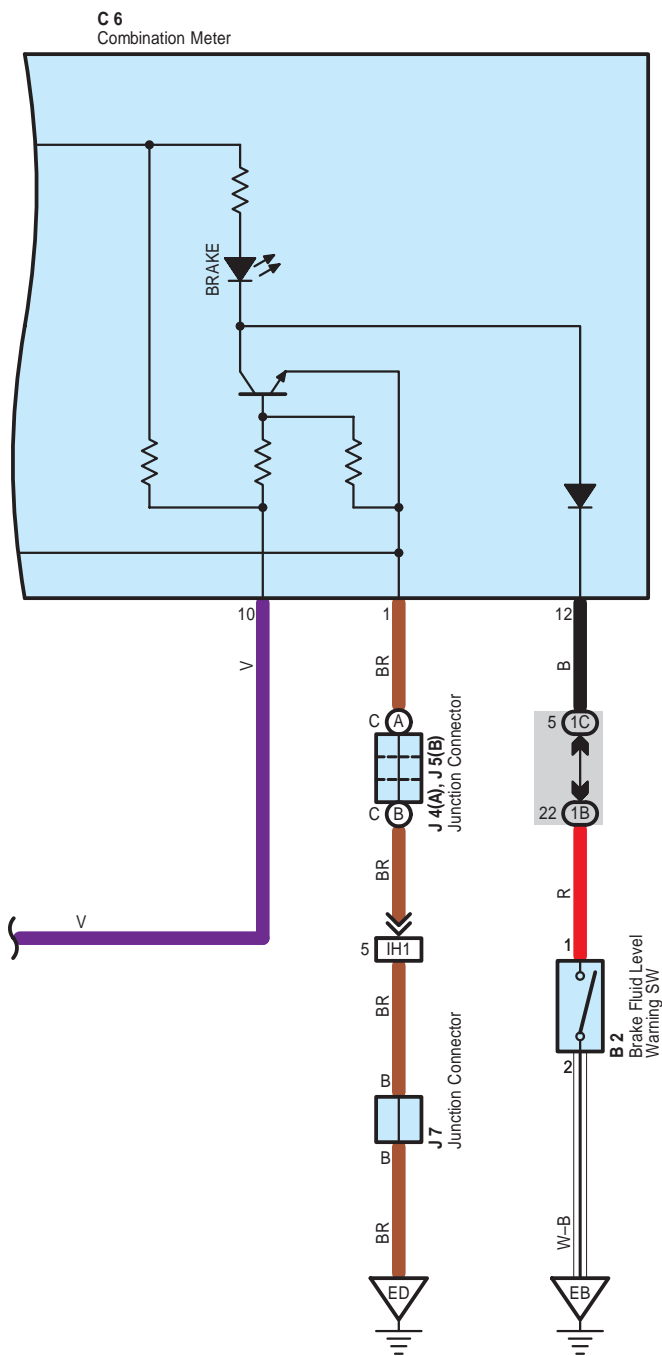

System Outline

* ABS system

This system controls the respective brake fluid pressures acting on the disc brake cylinders of the right front wheel, left front wheel and rear wheels when the brakes are applied in a panic stop so that the wheels do not lock. This results in improved directional stability and steerability during panic braking.

1. Input Signals

(1) Speed sensor signal

The speed of the wheels is detected and input to TERMINALS 9, 11, 31 and 33 of the skid control ECU with actuator.

(2) Stop light SW signal

A signal is input to TERMINAL 10 of the skid control ECU with actuator when the brake pedal is depressed.

2. System Operation

During sudden braking the skid control ECU with actuator has signals input from each sensor, which controls the current to the solenoid inside the actuator and lets the hydraulic pressure acting on each wheel cylinder escape to the reservoir. The pump inside the actuator is also operating at this time and it returns the brake fluid from the reservoir to the master cylinder, thus preventing locking of the vehicle wheels.

If the skid control ECU with actuator judges that the hydraulic pressure acting on the wheel cylinder is insufficient, the current on the solenoid is controlled and the hydraulic pressure is increased. Holding of the hydraulic pressure is also controlled by the skid control ECU with actuator, by the same method as above. Pressure reduction, holding and increase are repeated to maintain vehicle stability and to improve steerability during sudden braking.

○ : Parts Location

| Code | See Page | Code | See Page | Code | See Page |
|------|----------|------|----------|------|----------|
| B2 | 34 | J7 | 37 | S3 | 35 |
| C6 | 36 | P1 | 35 | S8 | 37 |
| D4 | 36 | P6 | 37 | S18 | 39 |
| J4 | A 37 | S1 | 35 | S19 | 39 |
| J5 | B 37 | S2 | 35 | | |

○ : Relay Blocks

| Code | See Page | Relay Blocks (Relay Block Location) |
|------|----------|---|
| 2 | 22 | Engine Room R/B (Engine Compartment Left) |

○ : Junction Block and Wire Harness Connector

| Code | See Page | Junction Block and Wire Harness (Connector Location) |
|------|----------|---|
| 1B | 24 | Engine Room Main Wire and Instrument Panel J/B (Lower Finish Panel) |
| 1C | 24 | Instrument Panel Wire and Instrument Panel J/B (Lower Finish Panel) |
| 1D | | |
| 1M | 25 | |
| 1S | | |

□ : Connector Joining Wire Harness and Wire Harness

| Code | See Page | Joining Wire Harness and Wire Harness (Connector Location) |
|------|----------|---|
| IC2 | 42 | Floor Wire and Instrument Panel Wire (Left Kick Panel) |
| IE2 | 42 | Engine Room Main Wire and Instrument Panel Wire (Behind of the Combination Meter) |
| IH1 | 43 | Engine Wire and Instrument Panel Wire (Cowl Side Panel RH) |
| IH2 | | |
| IJ1 | 43 | Floor No.2 Wire and Instrument Panel Wire (Right Kick Panel) |

▽ : Ground Points

| Code | See Page | Ground Points Location |
|------|----------|--------------------------------------|
| EA | 40 | Front Right Fender |
| EB | | |
| ED | 40 | Front Left Side of the Cylinder Head |

Tire Pressure Warning System

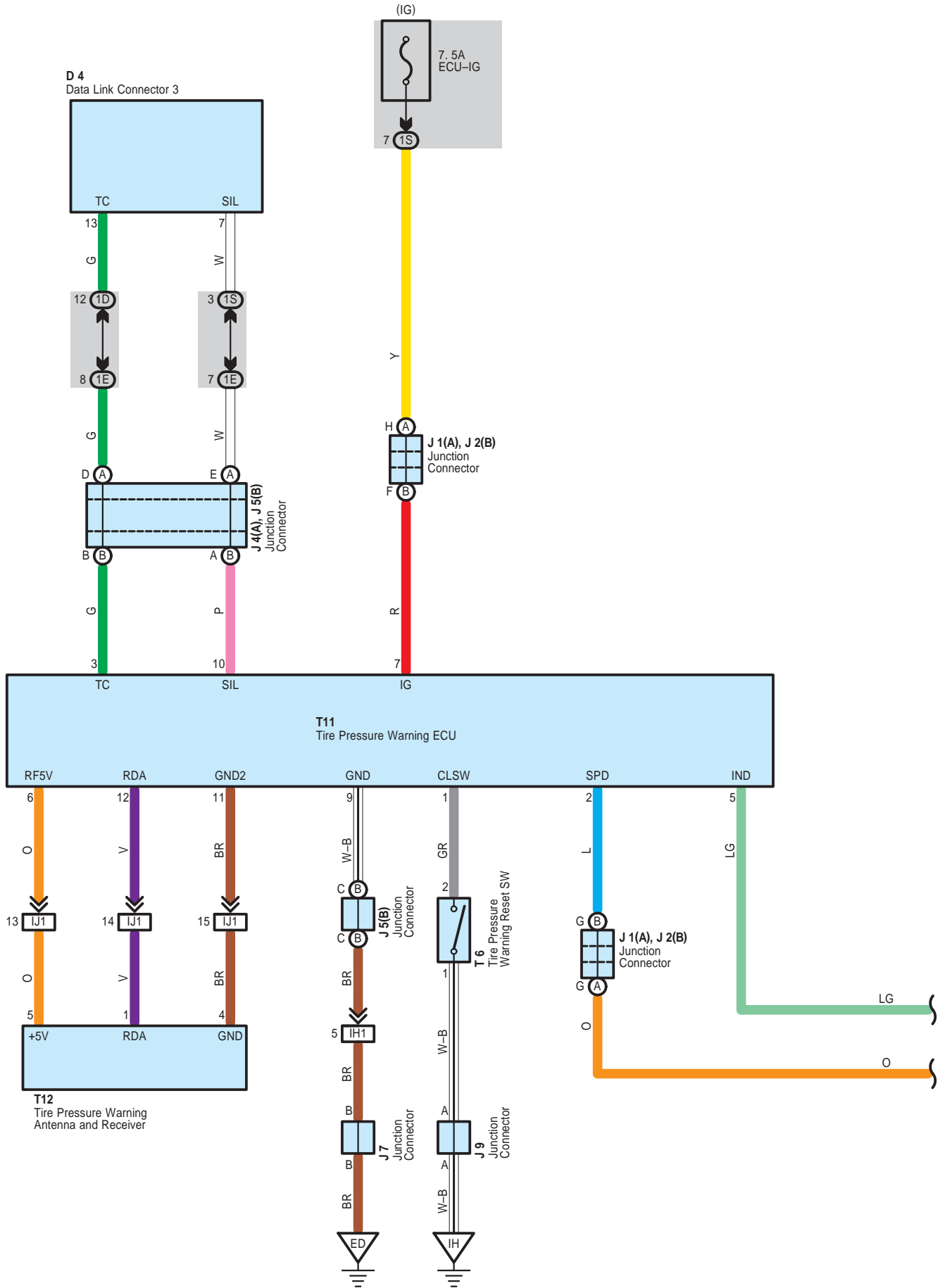

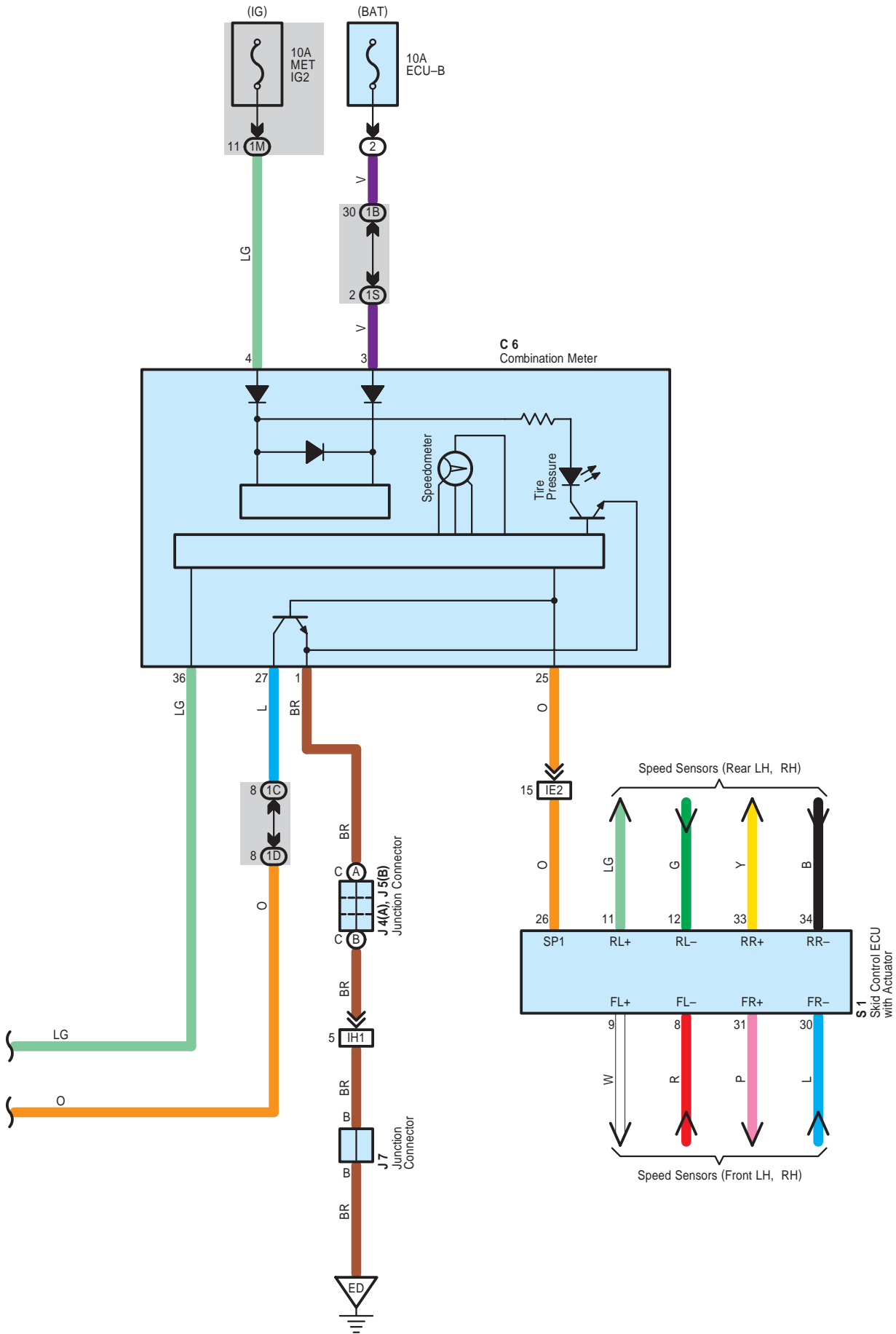

Tire Pressure Warning System

System Outline

The tire pressure warning valve and transmitter installed in the tire wheel detects the tire air pressure and transmits signals to the vehicle side receiver. When the detected tire air pressure is below a specified level, the warning light in the combination meter comes on to inform the driver.

Press the tire pressure warning reset SW for 3 seconds with the ignition SW at ON position after the tire pressure is adjusted to the specified value. It will lead the tire pressure warning ECU to warn the pressure according to the specified value.

Warnings when the tire pressure is low

* When the tire air pressure is below a specified level, the warning light in the combination meter comes on.

○ : Parts Location

| Code | See Page | Code | See Page | Code | See Page | |
|------|----------|------|----------|------|----------|----|
| C6 | 36 | J4 | A | 37 | S1 | 35 |
| D4 | 36 | J5 | B | 37 | T6 | 37 |
| J1 | A | J7 | | 37 | T11 | 37 |
| J2 | B | J9 | | 37 | T12 | 39 |

○ : Relay Blocks

| Code | See Page | Relay Blocks (Relay Block Location) |
|------|----------|---|
| 2 | 22 | Engine Room R/B (Engine Compartment Left) |

○ : Junction Block and Wire Harness Connector

| Code | See Page | Junction Block and Wire Harness (Connector Location) |
|------|----------|---|
| 1B | 24 | Engine Room Main Wire and Instrument Panel J/B (Lower Finish Panel) |
| 1C | 24 | Instrument Panel Wire and Instrument Panel J/B (Lower Finish Panel) |
| 1D | | |
| 1E | | |
| 1M | 25 | |
| 1S | | |

□ : Connector Joining Wire Harness and Wire Harness

| Code | See Page | Joining Wire Harness and Wire Harness (Connector Location) |
|------|----------|---|
| IE2 | 42 | Engine Room Main Wire and Instrument Panel Wire (Behind of the Combination Meter) |
| IH1 | 43 | Engine Wire and Instrument Panel Wire (Cowl Side Panel RH) |
| IJ1 | 43 | Floor No.2 Wire and Instrument Panel Wire (Right Kick Panel) |

▽ : Ground Points

| Code | See Page | Ground Points Location |
|------|----------|--------------------------------------|
| ED | 40 | Front Left Side of the Cylinder Head |
| IH | 42 | Cowl Brace RH |

NOTICE: When inspecting or repairing the SRS, perform service in accordance with the following precautionary instructions and the procedure, and precautions in the Repair Manual applicable for the model year.

- Malfunction symptoms of the SRS are difficult to confirm, so the DTCs become the most important source of information when troubleshooting. When troubleshooting the SRS, always inspect the DTCs before disconnecting the battery.
- **Work must be started more than 90 seconds after the ignition SW is turned to the "LOCK" position and the negative (-) terminal cable is disconnected from the battery.**
(The SRS is equipped with a back-up power source so that if work is started within 90 seconds from disconnecting the negative (-) terminal cable of the battery, the SRS may deploy.)
- When the negative (-) terminal cable is disconnected from the battery, the memory of the clock and audio system will be cleared. So before starting work, make a record of the contents in the audio memory system. When work is finished, reset the audio systems as they were before and adjust the clock. Some vehicles have power tilt steering, power telescopic steering, power seat and power outside rear view mirror which are all equipped with memory function. However, it is not possible to make a record of these memory contents. So when the work is finished, it will be necessary to explain it to your customer, and ask the customer to adjust the features and reset the memory. To avoid erasing the memory in each system, never use a back-up power supply from outside the vehicle.
- Before repair, remove the airbag sensor if shocks are likely to be applied to the sensor during repair.
- Do not expose the following parts directly to hot air or flame;
- Even in cases of a minor collision where the SRS does not deploy, the following parts should be inspected;
- Never use SRS parts from another vehicle. When replacing parts, replace with new parts.
- For the purpose of reuse, never disassemble and repair the following parts.
- If the following parts have been dropped, or have cracks, dents and other defects in their case, bracket, and connector, replace with new one.
- Use a volt/ohmmeter with high impedance (10 k Ω /V minimum) for troubleshooting electrical circuits of the system.
- Information labels are attached to the periphery of the SRS components. Follow the instructions of the notice.
- After work on the SRS is completed, check the SRS warning light.
- If the vehicle is equipped with a mobile communication system, refer to the precaution in the IN section of the Repair Manual.

- * Steering wheel pad
- * Front passenger airbag assembly
- * Side airbag assembly
- * Curtain shield airbag assembly
- * Knee airbag assembly
- * Seat belt pretensioner
- * Center airbag sensor assembly
- * Front airbag sensor assembly
- * Side airbag sensor assembly
- * Rear airbag sensor assembly

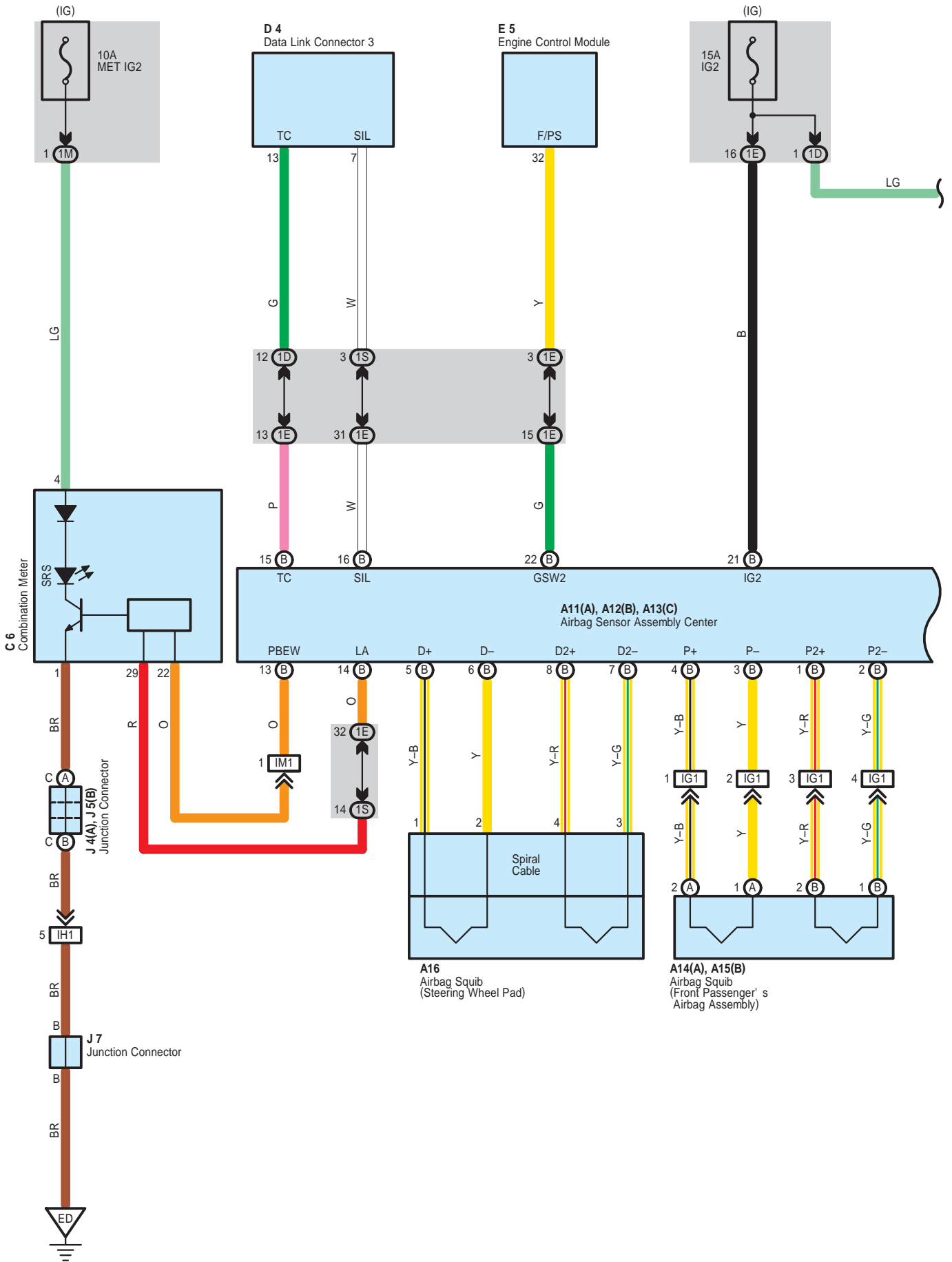

* 1 : w/ Side Airbag

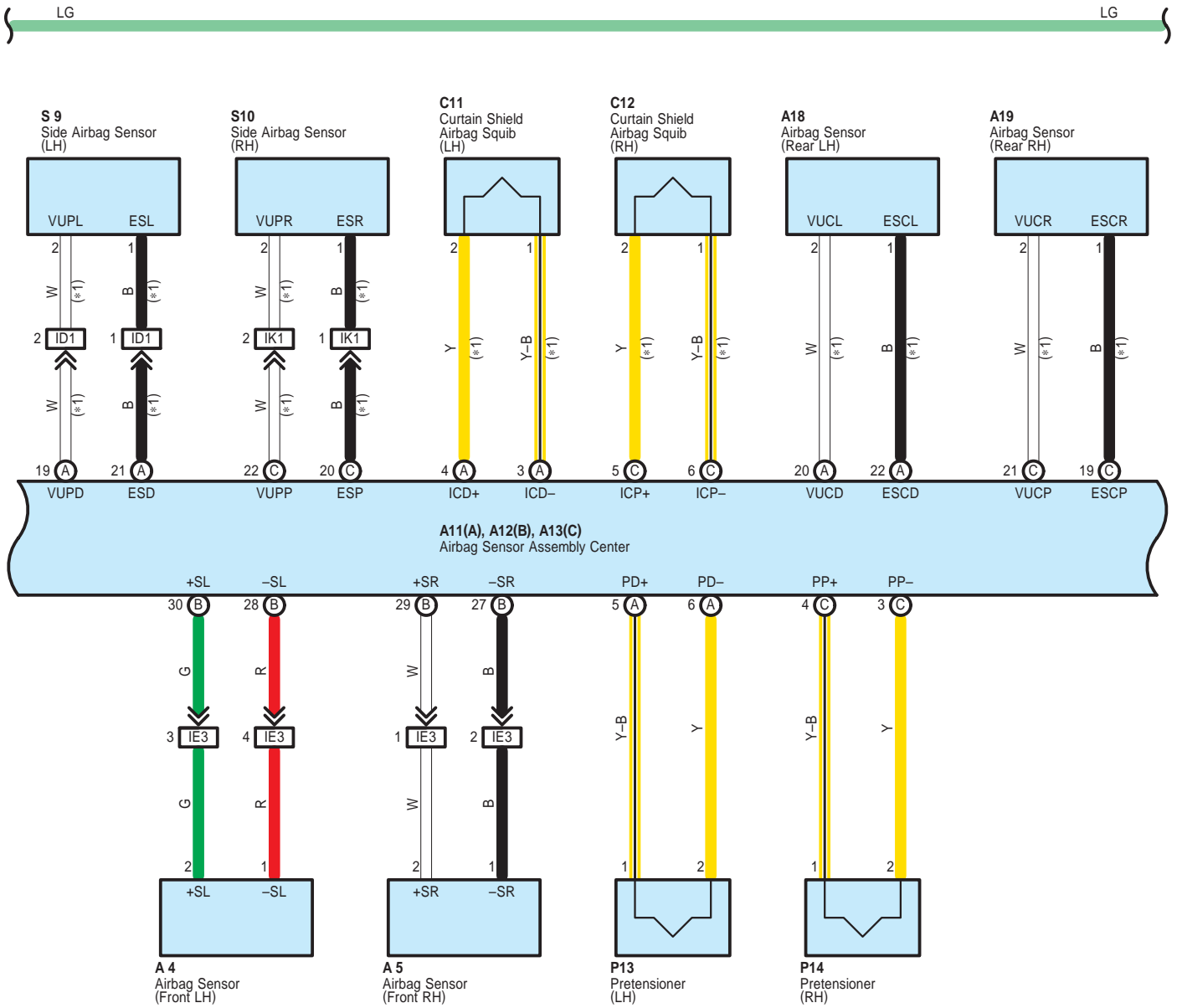

- * 1 : w/ Side Airbag
- * 2 : w/ Cruise Control
- * 3 : w/o Cruise Control

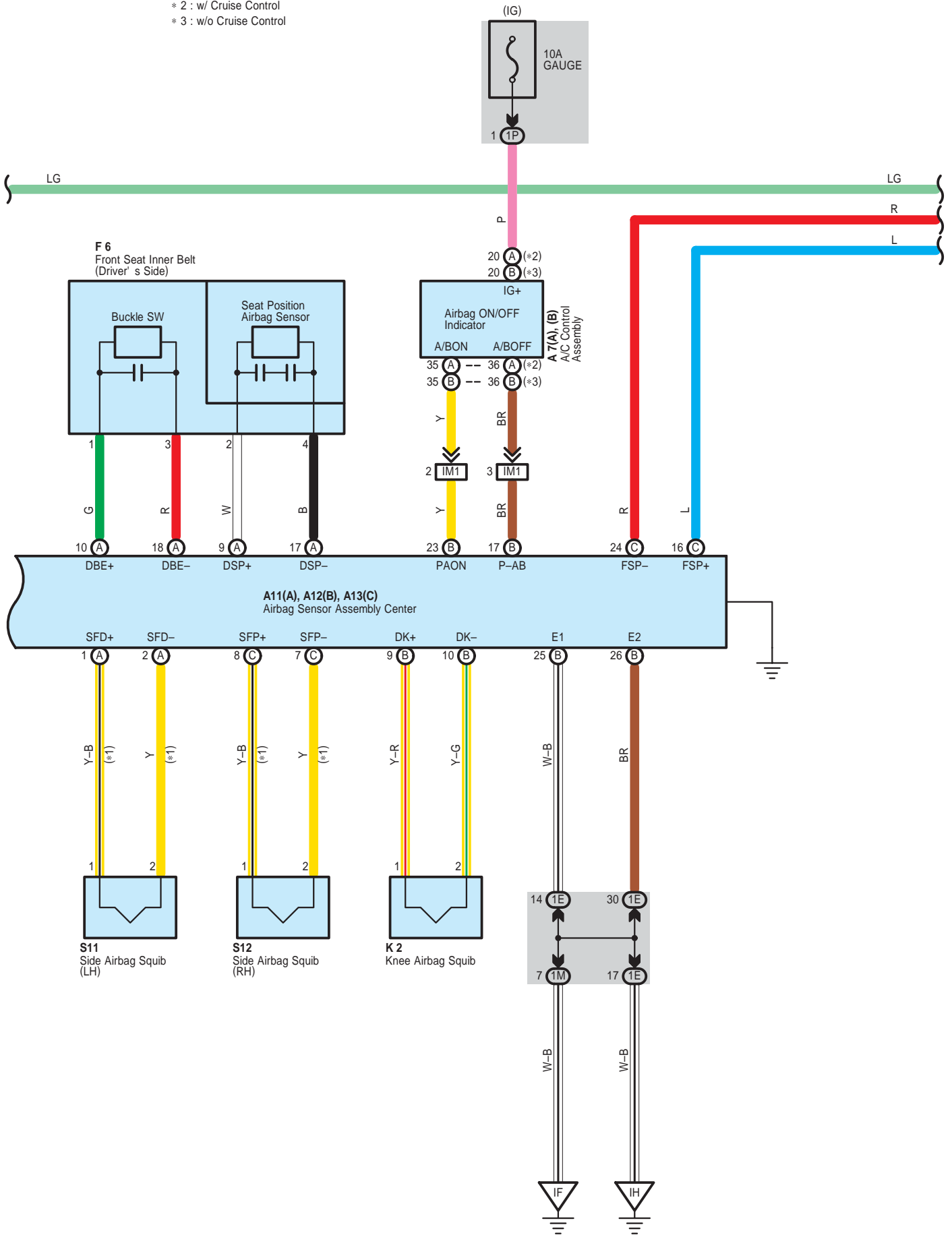

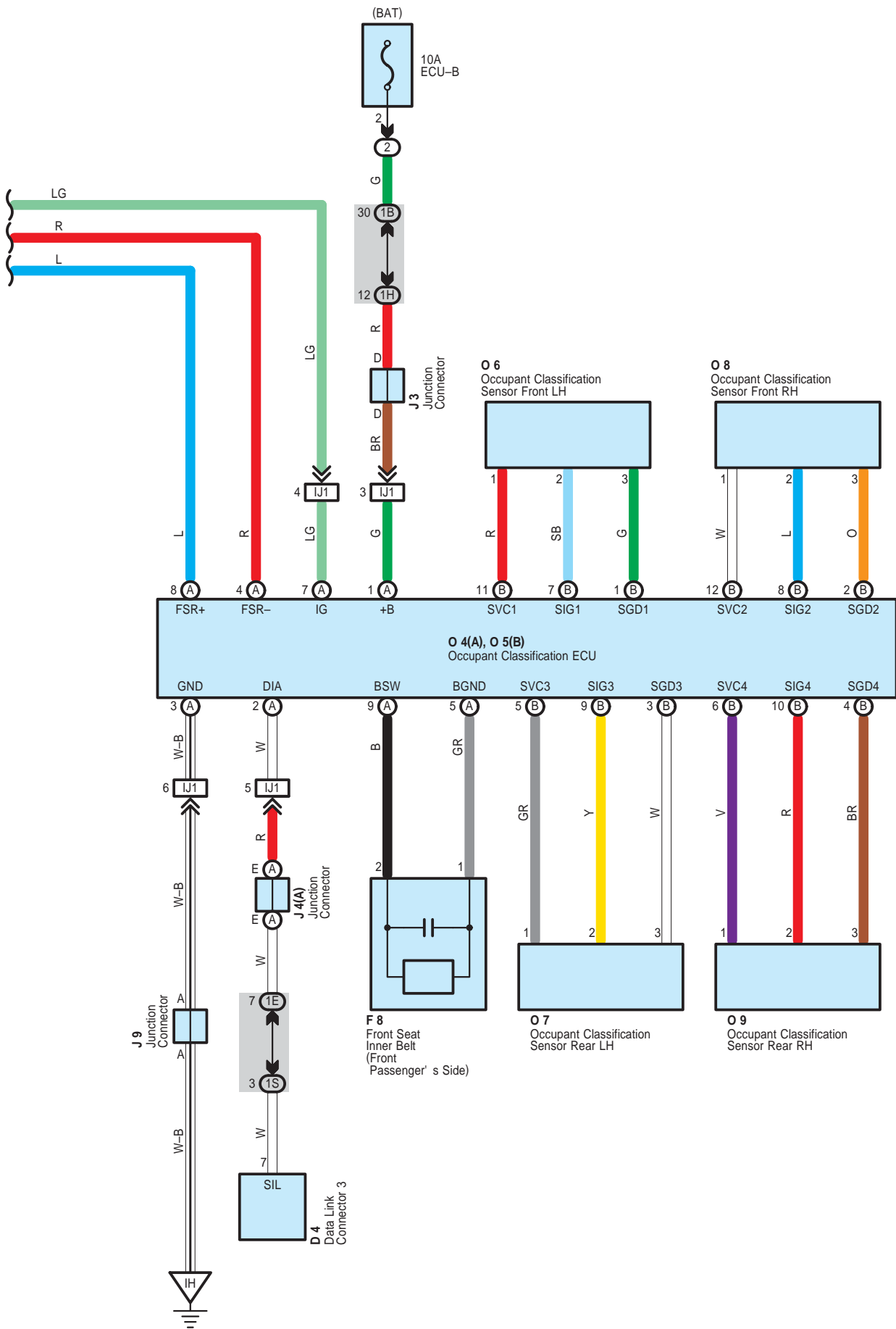

System Outline

- * The system reaches an ignition judgment to deploy the following device based on the signals received from the front airbag sensor and deceleration sensor.
 - Driver Airbag
 - Front Passenger Airbag
 - Knee Airbag
 - Seat Belt Pretensioner
- * The system reaches an ignition judgment to deploy the following device based on the signals received from the side airbag sensors.
 - Side Airbags
 - Curtain Shield Airbags
- * The dual-stage SRS airbag system has been used for the driver and front passenger airbags. This system controls the optimal airbag inflation by judging the extent of impact, seat position (driver seat) and whether or not the seat belt is fastened (driver seat) and information from the Front Passenger Occupant Classification System.
- * The front passenger occupant classification system judges whether the front passenger seat is occupied by an adult or child (with child seat) or is unoccupied, according to the load applied to the front passenger seat and whether the seat belt is buckled. Based on the results, it restricts the deployment of the front passenger airbag, front passenger side airbag, and front passenger seat belt pretensioner. In addition, the system informs the driver of the result of the judgment through the use of the AIRBAG ON/OFF indicator lights.
- * The airbag sensor assembly transmits a signal to the Engine Control Module in order to stop the fuel pump.

○ : Parts Location

| Code | See Page | Code | See Page | Code | See Page |
|------|----------|--------|----------|--------|----------|
| A4 | 34 | C11 | 38 | O5 B | 39 |
| A5 | 34 | C12 | 38 | O6 | 39 |
| A7 | A 36 | D4 | 36 | O7 | 39 |
| | B 36 | E5 | 36 | O8 | 39 |
| A11 | A 36 | F6 | 38 | O9 | 39 |
| A12 | B 36 | F8 | 38 | P13 | 39 |
| A13 | C 36 | J3 | 37 | P14 | 39 |
| A14 | A 36 | J4 A | 37 | S9 | 39 |
| A15 | B 36 | J5 B | 37 | S10 | 39 |
| A16 | 36 | J7 | 37 | S11 | 39 |
| A18 | 38 | J9 | 37 | S12 | 39 |
| A19 | 38 | K2 | 37 | | |
| C6 | 36 | O4 A | 39 | | |

○ : Relay Blocks

| Code | See Page | Relay Blocks (Relay Block Location) |
|------|----------|---|
| 2 | 22 | Engine Room R/B (Engine Compartment Left) |

○ : Junction Block and Wire Harness Connector

| Code | See Page | Junction Block and Wire Harness (Connector Location) |
|------|----------|---|
| 1B | 24 | Engine Room Main Wire and Instrument Panel J/B (Lower Finish Panel) |
| 1D | 24 | Instrument Panel Wire and Instrument Panel J/B (Lower Finish Panel) |
| 1E | | |
| 1H | | |
| 1M | 25 | |
| 1P | | |
| 1S | | |

 : **Connector Joining Wire Harness and Wire Harness**

| Code | See Page | Joining Wire Harness and Wire Harness (Connector Location) |
|------|----------|--|
| ID1 | 42 | Front Door LH Wire and Floor Wire (Left Kick Panel) |
| IE3 | 42 | Engine Room Main Wire and Instrument Panel Wire (Behind of the Combination Meter) |
| IG1 | 43 | Instrument Panel Wire and Instrument Panel Wire Assembly (Behind of the Glove Box) |
| IH1 | 43 | Engine Wire and Instrument Panel Wire (Cowl Side Panel RH) |
| IJ1 | 43 | Floor No.2 Wire and Instrument Panel Wire (Right Kick Panel) |
| IK1 | 43 | Front Door RH Wire and Floor No.2 Wire (Right Kick Panel) |
| IM1 | 43 | Instrument Panel Wire and Instrument Panel Wire (Left Kick Panel) |

 : **Ground Points**

| Code | See Page | Ground Points Location |
|------|----------|--------------------------------------|
| ED | 40 | Front Left Side of the Cylinder Head |
| IF | 42 | Cowl Brace LH |
| IH | 42 | Cowl Brace RH |

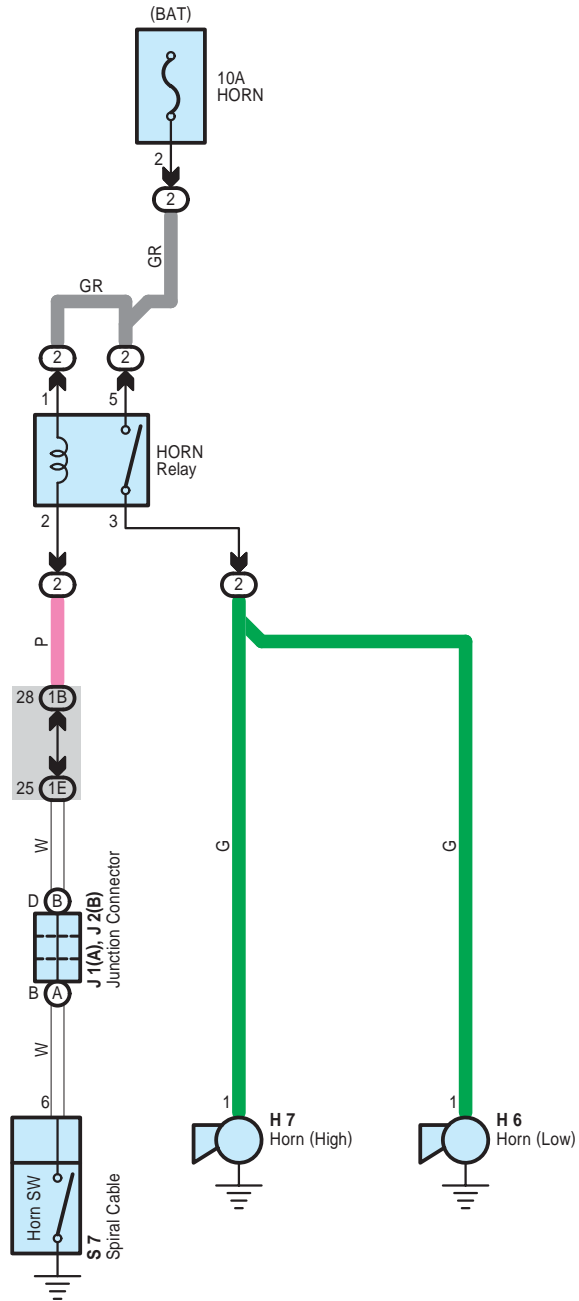

: **Parts Location**

| Code | See Page | Code | | See Page | Code | See Page |
|------|----------|------|---|----------|------|----------|
| H6 | 34 | J1 | A | 37 | S7 | 37 |
| H7 | 34 | J2 | B | 37 | | |

: **Relay Blocks**

| Code | See Page | Relay Blocks (Relay Block Location) |
|------|----------|---|
| 2 | 22 | Engine Room R/B (Engine Compartment Left) |

: **Junction Block and Wire Harness Connector**

| Code | See Page | Junction Block and Wire Harness (Connector Location) |
|------|----------|---|
| 1B | 24 | Engine Room Main Wire and Instrument Panel J/B (Lower Finish Panel) |
| 1E | 24 | Instrument Panel Wire and Instrument Panel J/B (Lower Finish Panel) |

Cigarette Lighter

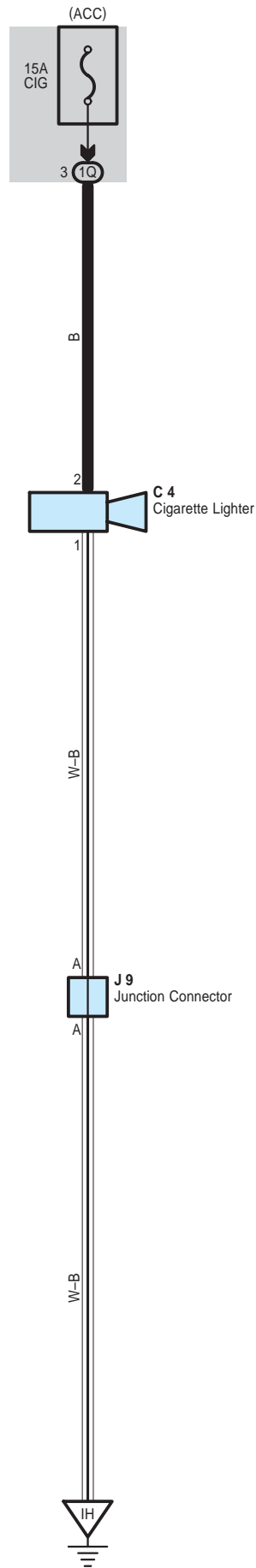

 : **Parts Location**

| Code | See Page | Code | See Page | Code | See Page |
|------|----------|------|----------|------|----------|
| C4 | 36 | J9 | 37 | | |

 : **Junction Block and Wire Harness Connector**

| Code | See Page | Junction Block and Wire Harness (Connector Location) |
|------|----------|---|
| 1Q | 25 | Instrument Panel Wire and Instrument Panel J/B (Lower Finish Panel) |

 : **Ground Points**

| Code | See Page | Ground Points Location |
|------|----------|------------------------|
| IH | 42 | Cowl Brace RH |

Power Outlet

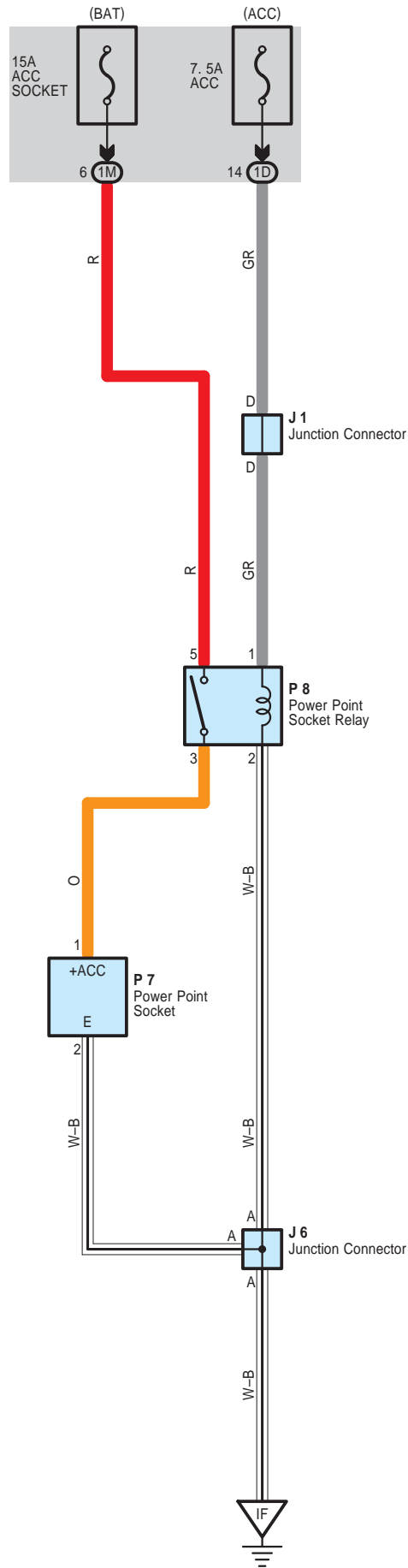

 : **Parts Location**

| Code | See Page | Code | See Page | Code | See Page |
|------|----------|------|----------|------|----------|
| J1 | 37 | P7 | 37 | | |
| J6 | 37 | P8 | 37 | | |

 : **Junction Block and Wire Harness Connector**

| Code | See Page | Junction Block and Wire Harness (Connector Location) |
|------|----------|---|
| 1D | 24 | Instrument Panel Wire and Instrument Panel J/B (Lower Finish Panel) |
| 1M | 25 | |

 : **Ground Points**

| Code | See Page | Ground Points Location |
|------|----------|------------------------|
| IF | 42 | Cowl Brace LH |

Key Reminder

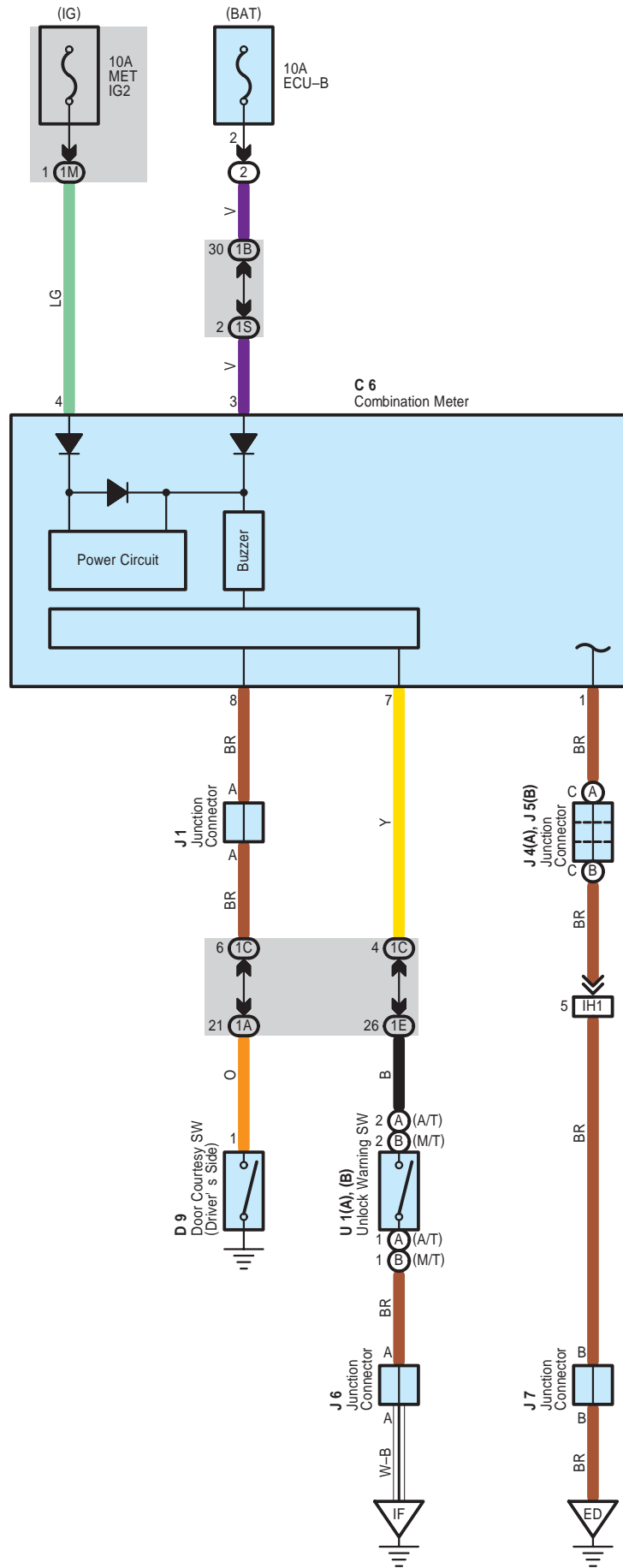

System Outline

Current is always applied from the ECU-B fuse to TERMINAL 3 of the combination meter. When the ignition SW is turned to ON position, the current from the MET IG2 fuse flows to TERMINAL 4 of the combination meter.

Key Reminder System

When the driver door is opened with the ignition SW off and ignition key remaining in the key cylinder (Unlock warning SW on), a signal is input from the unlock warning SW to TERMINAL 7 of the combination meter, and from the door courtesy SW (Driver's side) to TERMINAL 8 of the combination meter. As a result, the buzzer in the combination meter goes on and warns the driver that the key is remaining in the key cylinder.

: Parts Location

| Code | See Page | Code | See Page | Code | See Page | | |
|------|----------|------|----------|------|----------|----|----|
| C6 | 36 | J4 | A | 37 | J7 | 37 | |
| D9 | 38 | J5 | B | 37 | U1 | A | 37 |
| J1 | 37 | J6 | | 37 | | B | 37 |

: Relay Blocks

| Code | See Page | Relay Blocks (Relay Block Location) |
|------|----------|---|
| 2 | 22 | Engine Room R/B (Engine Compartment Left) |

: Junction Block and Wire Harness Connector

| Code | See Page | Junction Block and Wire Harness (Connector Location) |
|------|----------|---|
| 1A | 24 | Floor Wire and Instrument Panel J/B (Lower Finish Panel) |
| 1B | 24 | Engine Room Main Wire and Instrument Panel J/B (Lower Finish Panel) |
| 1C | 24 | Instrument Panel Wire and Instrument Panel J/B (Lower Finish Panel) |
| 1E | | |
| 1M | 25 | |
| 1S | | |

: Connector Joining Wire Harness and Wire Harness

| Code | See Page | Joining Wire Harness and Wire Harness (Connector Location) |
|------|----------|--|
| IH1 | 43 | Engine Wire and Instrument Panel Wire (Cowl Side Panel RH) |

: Ground Points

| Code | See Page | Ground Points Location |
|------|----------|--------------------------------------|
| ED | 40 | Front Left Side of the Cylinder Head |
| IF | 42 | Cowl Brace LH |

Light Reminder

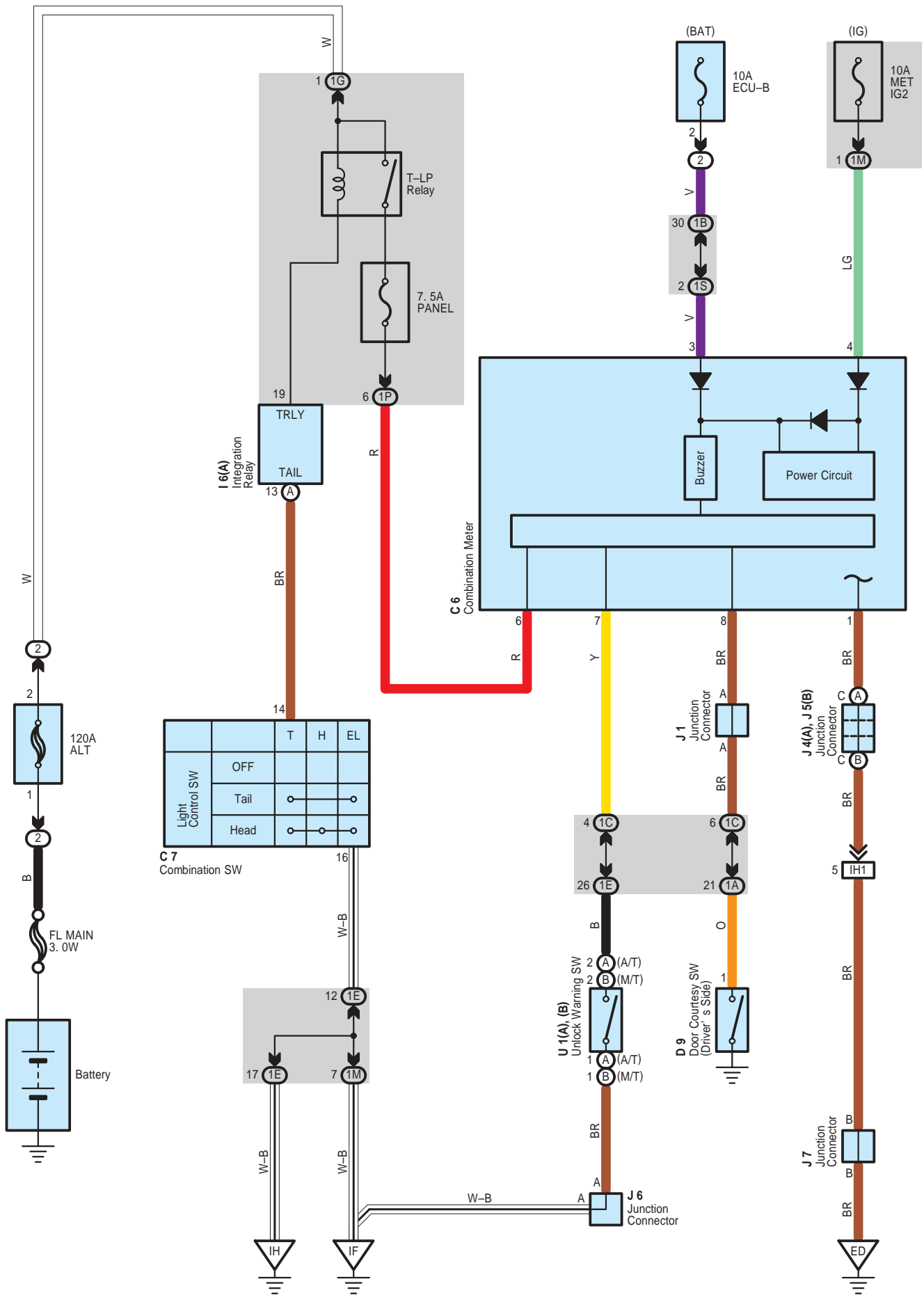

System Outline

The current is applied at all times to TERMINAL 3 of the combination meter through the ECU-B fuse. When the ignition SW is turned to ON position, the current flows to TERMINAL 4 of the combination meter through the MET IG2 fuse. When the light control SW is turned to TAIL or HEAD position, current is applied to TERMINAL 6 of the combination meter through the PANEL fuse.

Light Reminder System

When the light control SW is in TAIL or HEAD position, the ignition SW turned to OFF from ON position, ignition key is not in the key cylinder and the driver's door opened (Door courtesy SW on), the current flows to TERMINAL 4 of the combination meter stops. As a result, the combination meter is activated and current flows from TERMINAL 3 of the combination meter, the buzzer in the combination meter goes on to remind the light is lighting up.

: Parts Location

| Code | See Page | Code | See Page | Code | See Page |
|------|----------|------|----------|------|----------|
| C6 | 36 | J1 | 37 | J7 | 37 |
| C7 | 36 | J4 | A | 37 | U1 |
| D9 | 38 | J5 | B | 37 | |
| I6 | A | 37 | J6 | 37 | |

: Relay Blocks

| Code | See Page | Relay Blocks (Relay Block Location) |
|------|----------|---|
| 2 | 22 | Engine Room R/B (Engine Compartment Left) |

: Junction Block and Wire Harness Connector

| Code | See Page | Junction Block and Wire Harness (Connector Location) |
|------|----------|---|
| 1A | 24 | Floor Wire and Instrument Panel J/B (Lower Finish Panel) |
| 1B | 24 | Engine Room Main Wire and Instrument Panel J/B (Lower Finish Panel) |
| 1C | 24 | Instrument Panel Wire and Instrument Panel J/B (Lower Finish Panel) |
| 1E | | |
| 1G | 24 | Engine Room Main Wire and Instrument Panel J/B (Lower Finish Panel) |
| 1M | 25 | Instrument Panel Wire and Instrument Panel J/B (Lower Finish Panel) |
| 1P | | |
| 1S | | |

: Connector Joining Wire Harness and Wire Harness

| Code | See Page | Joining Wire Harness and Wire Harness (Connector Location) |
|------|----------|--|
| IH1 | 43 | Engine Wire and Instrument Panel Wire (Cowl Side Panel RH) |

: Ground Points

| Code | See Page | Ground Points Location |
|------|----------|--------------------------------------|
| ED | 40 | Front Left Side of the Cylinder Head |
| IF | 42 | Cowl Brace LH |
| IH | 42 | Cowl Brace RH |

Seat Belt Warning

* 1 : w/ Cruise Control
 * 2 : w/o Cruise Control

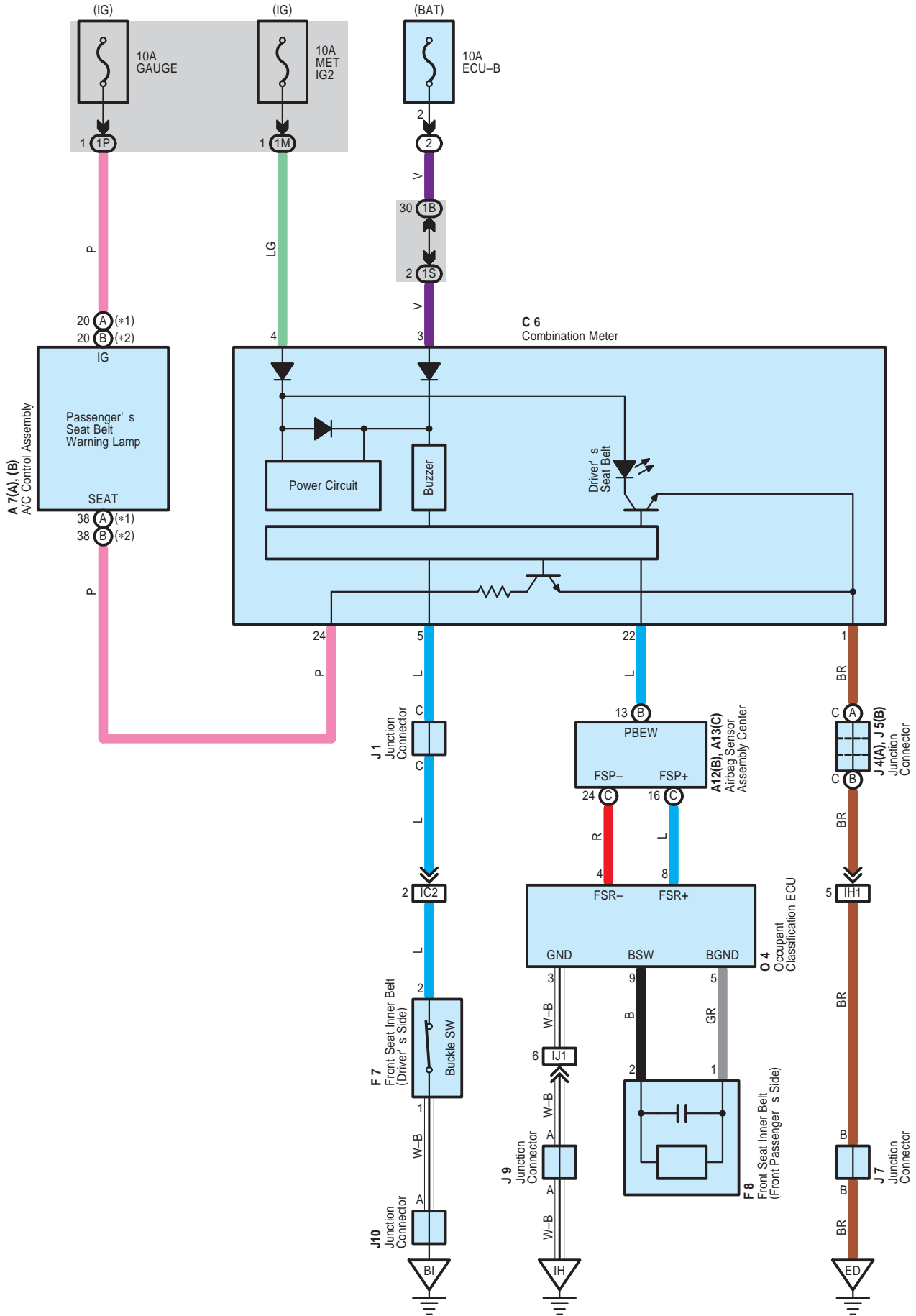

System Outline

Current is always applied from the ECU-B fuse to TERMINAL 3 of the combination meter. When the ignition SW is turned to ON position, the current from the MET IG2 fuse flows to TERMINAL 4 of the combination meter.

Seat Belt Warning System

When the ignition SW turned on, a signal is input to the combination meter. To determine whether the driver has fastened the seat belt, a signal is input from the front seat inner belt (Driver's side) to TERMINAL 5 of the combination meter. When the seat belt is not fastened, the seat belt warning light in the combination meter blinks, and emits a warning sound.

In addition, the front passenger is recognized by a sensor (Occupant detection sensor) is installed in the front passenger seat, and determines whether the seat belt is fastened. When not fastened, the signals from the front seat inner belt (Front passenger's side) is input to TERMINAL 22 of the combination meter, and the passenger's seat belt warning lamp blinks.

○ : Parts Location

| Code | | See Page | Code | | See Page | Code | | See Page |
|------|---|----------|------|---|----------|------|--|----------|
| A7 | A | 36 | F7 | | 38 | J7 | | 37 |
| | B | 36 | F8 | | 38 | J9 | | 37 |
| A12 | B | 36 | J1 | | 37 | J10 | | 38 |
| A13 | C | 36 | J4 | A | 37 | O4 | | 39 |
| C6 | | 36 | J5 | B | 37 | | | |

○ : Relay Blocks

| Code | See Page | Relay Blocks (Relay Block Location) |
|------|----------|---|
| 2 | 22 | Engine Room R/B (Engine Compartment Left) |

○ : Junction Block and Wire Harness Connector

| Code | See Page | Junction Block and Wire Harness (Connector Location) |
|------|----------|---|
| 1B | 24 | Engine Room Main Wire and Instrument Panel J/B (Lower Finish Panel) |
| 1M | 25 | Instrument Panel Wire and Instrument Panel J/B (Lower Finish Panel) |
| 1P | | |
| 1S | | |

□ : Connector Joining Wire Harness and Wire Harness

| Code | See Page | Joining Wire Harness and Wire Harness (Connector Location) |
|------|----------|--|
| IC2 | 42 | Floor Wire and Instrument Panel Wire (Left Kick Panel) |
| IH1 | 43 | Engine Wire and Instrument Panel Wire (Cowl Side Panel RH) |
| IJ1 | 43 | Floor No.2 Wire and Instrument Panel Wire (Right Kick Panel) |

▽ : Ground Points

| Code | See Page | Ground Points Location |
|------|----------|--------------------------------------|
| ED | 40 | Front Left Side of the Cylinder Head |
| IH | 42 | Cowl Brace RH |
| BI | 44 | Quarter Panel LH |

Rear Window Defogger

* 1 : w/ Cruise Control
 * 2 : w/o Cruise Control

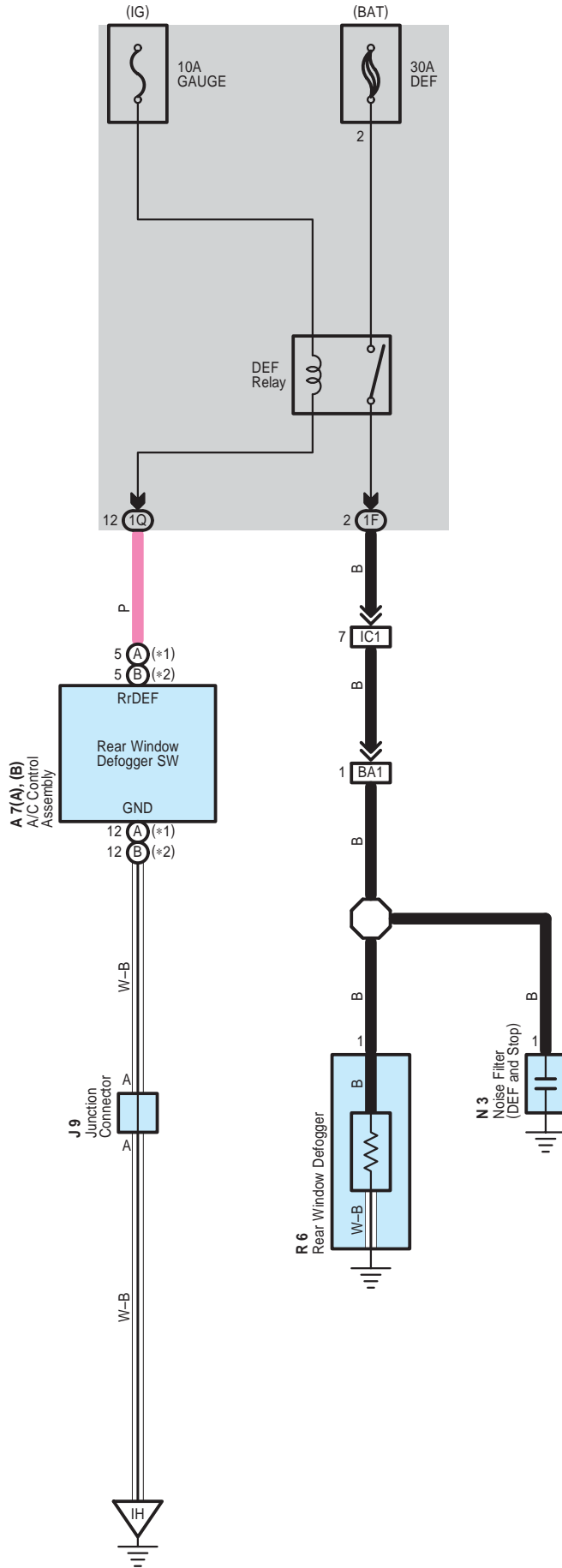

 : **Parts Location**

| Code | See Page | Code | See Page | Code | See Page | |
|------|----------|------|----------|------|----------|----|
| A7 | A | 36 | J9 | 37 | R6 | 39 |
| | B | 36 | N3 | 38 | | |

 : **Junction Block and Wire Harness Connector**

| Code | See Page | Junction Block and Wire Harness (Connector Location) |
|------|----------|---|
| 1F | 24 | Instrument Panel Wire and Instrument Panel J/B (Lower Finish Panel) |
| 1Q | 25 | |

 : **Connector Joining Wire Harness and Wire Harness**

| Code | See Page | Joining Wire Harness and Wire Harness (Connector Location) |
|------|----------|---|
| IC1 | 42 | Floor Wire and Instrument Panel Wire (Left Kick Panel) |
| BA1 | 44 | Back Door No.1 Wire and Floor Wire (Back Window Upper Frame LH) |

 : **Ground Points**

| Code | See Page | Ground Points Location |
|------|----------|------------------------|
| IH | 42 | Cowl Brace RH |

Audio System

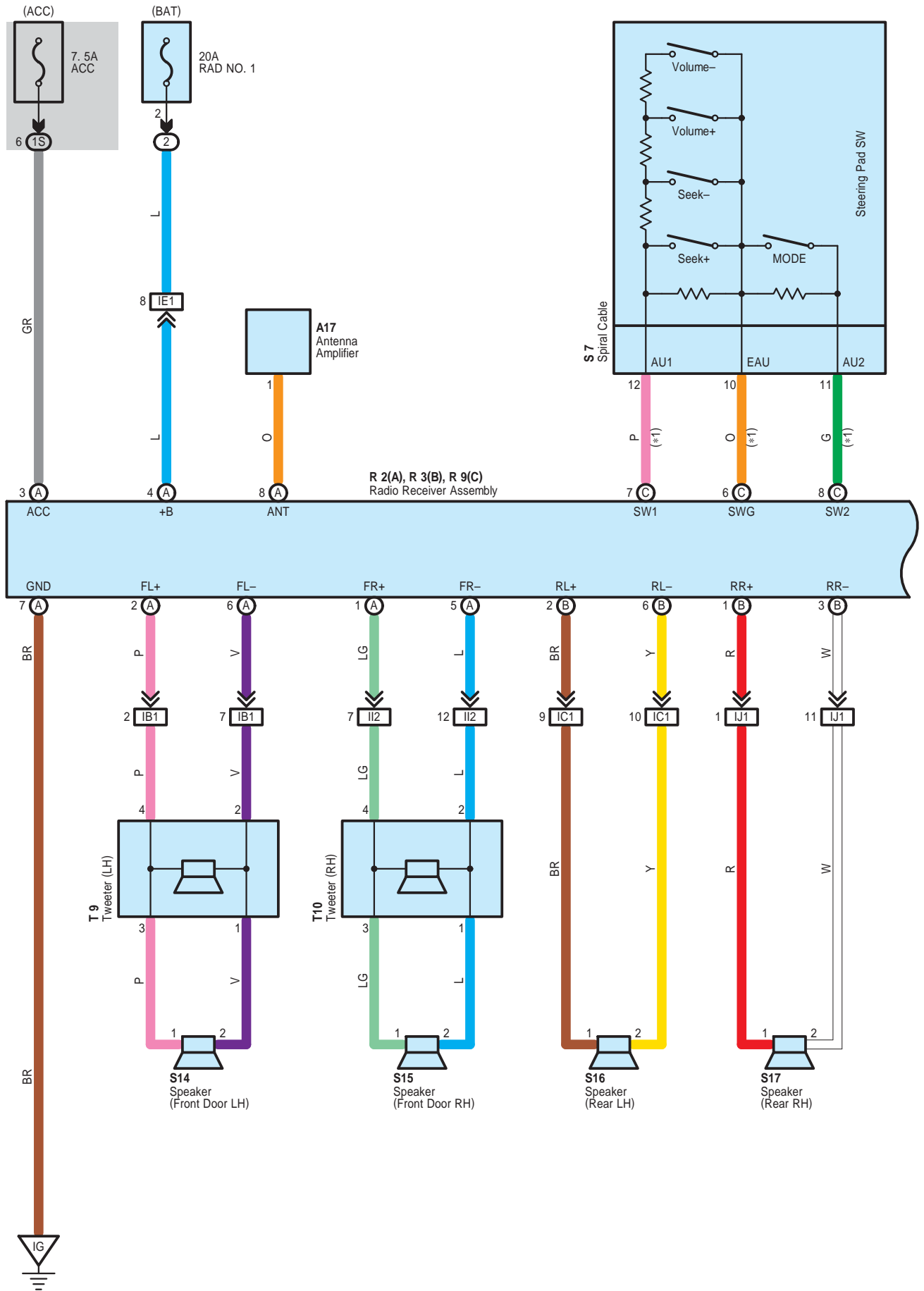

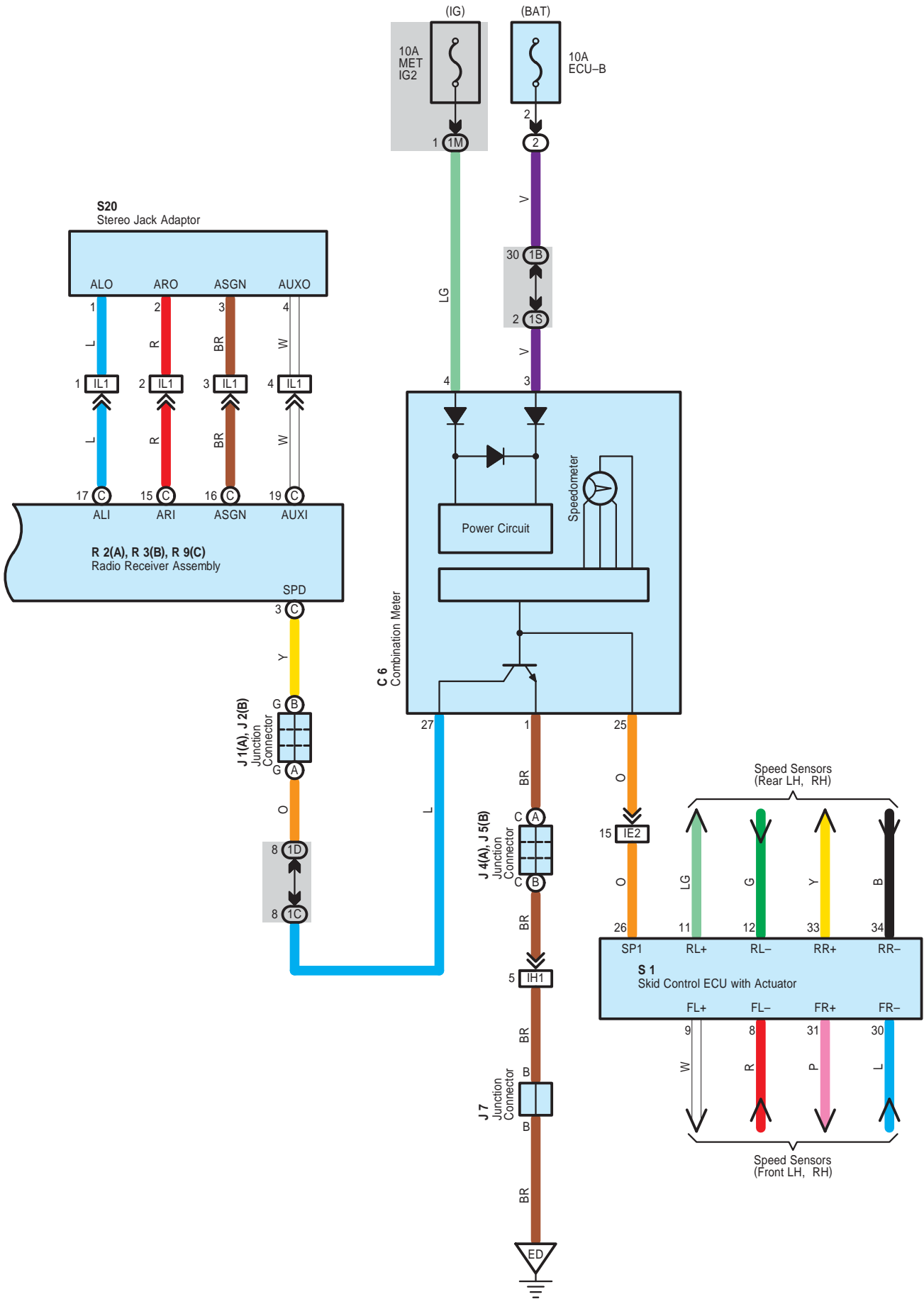

Audio System

: Parts Location

| Code | | See Page | Code | | See Page | Code | | See Page |
|------|---|----------|------|---|----------|------|--|----------|
| A17 | | 36 | R2 | A | 37 | S16 | | 39 |
| C6 | | 36 | R3 | B | 37 | S17 | | 39 |
| J1 | A | 37 | R9 | C | 37 | S20 | | 37 |
| J2 | B | 37 | S1 | | 35 | T9 | | 39 |
| J4 | A | 37 | S7 | | 37 | T10 | | 39 |
| J5 | B | 37 | S14 | | 39 | | | |
| J7 | | 37 | S15 | | 39 | | | |

: Relay Blocks

| Code | See Page | Relay Blocks (Relay Block Location) |
|------|----------|---|
| 2 | 22 | Engine Room R/B (Engine Compartment Left) |

: Junction Block and Wire Harness Connector

| Code | See Page | Junction Block and Wire Harness (Connector Location) |
|------|----------|---|
| 1B | 24 | Engine Room Main Wire and Instrument Panel J/B (Lower Finish Panel) |
| 1C | 24 | Instrument Panel Wire and Instrument Panel J/B (Lower Finish Panel) |
| 1D | | |
| 1M | 25 | |
| 1S | | |

: Connector Joining Wire Harness and Wire Harness

| Code | See Page | Joining Wire Harness and Wire Harness (Connector Location) |
|------|----------|---|
| IB1 | 42 | Front Door LH Wire and Instrument Panel Wire (Left Kick Panel) |
| IC1 | 42 | Floor Wire and Instrument Panel Wire (Left Kick Panel) |
| IE1 | 42 | Engine Room Main Wire and Instrument Panel Wire (Behind of the Combination Meter) |
| IE2 | | |
| IH1 | 43 | Engine Wire and Instrument Panel Wire (Cowl Side Panel RH) |
| II2 | 43 | Front Door RH Wire and Instrument Panel Wire (Right Kick Panel) |
| IJ1 | 43 | Floor No.2 Wire and Instrument Panel Wire (Right Kick Panel) |
| IL1 | 43 | Console Box Wire and Instrument Panel Wire (Under the Console Box) |

: Ground Points

| Code | See Page | Ground Points Location |
|------|----------|--------------------------------------|
| ED | 40 | Front Left Side of the Cylinder Head |
| IG | 42 | Instrument Panel Brace LH |

Combination Meter

* 1 : w/ Cruise Control
 * 2 : w/o Cruise Control

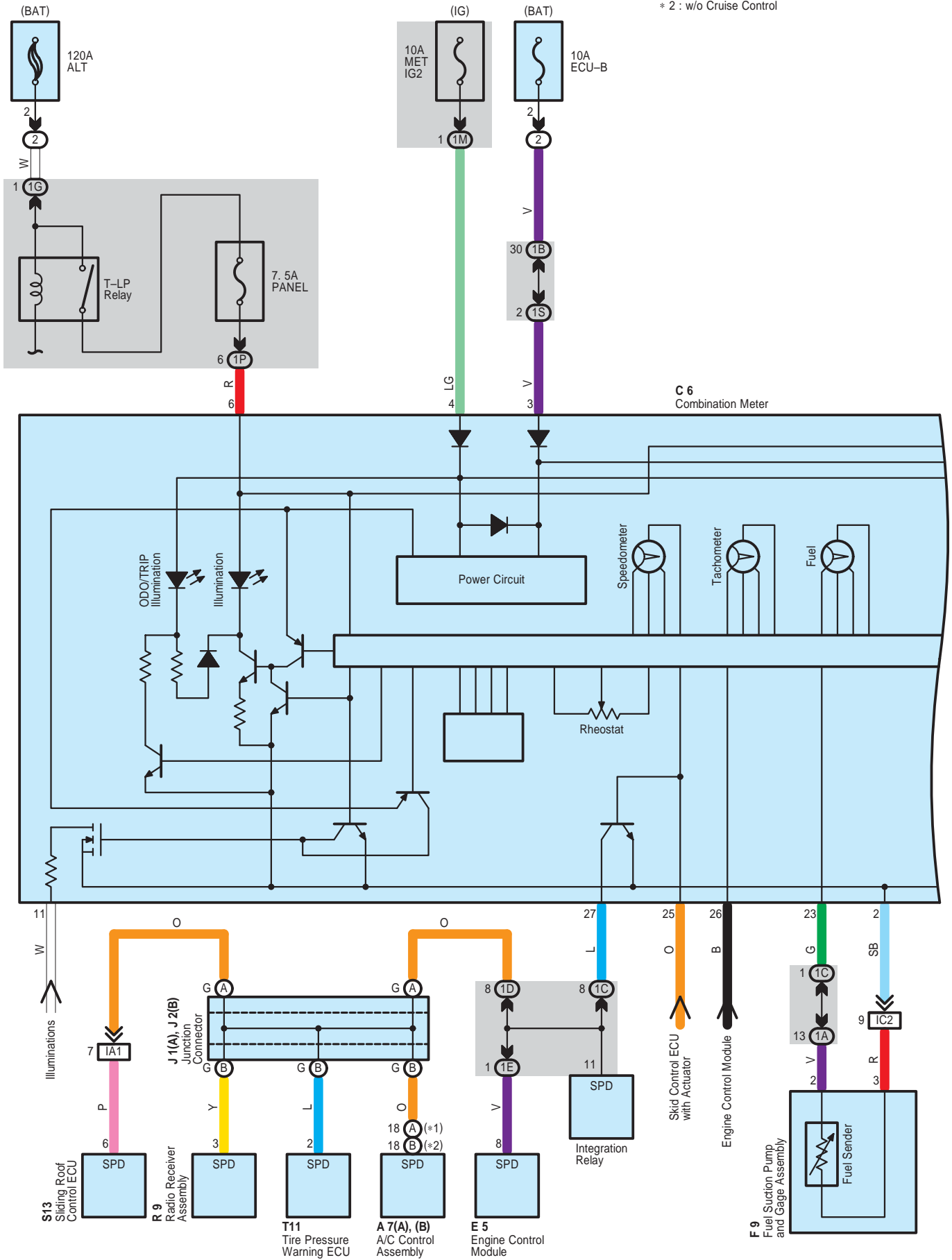

C 6
Combination Meter

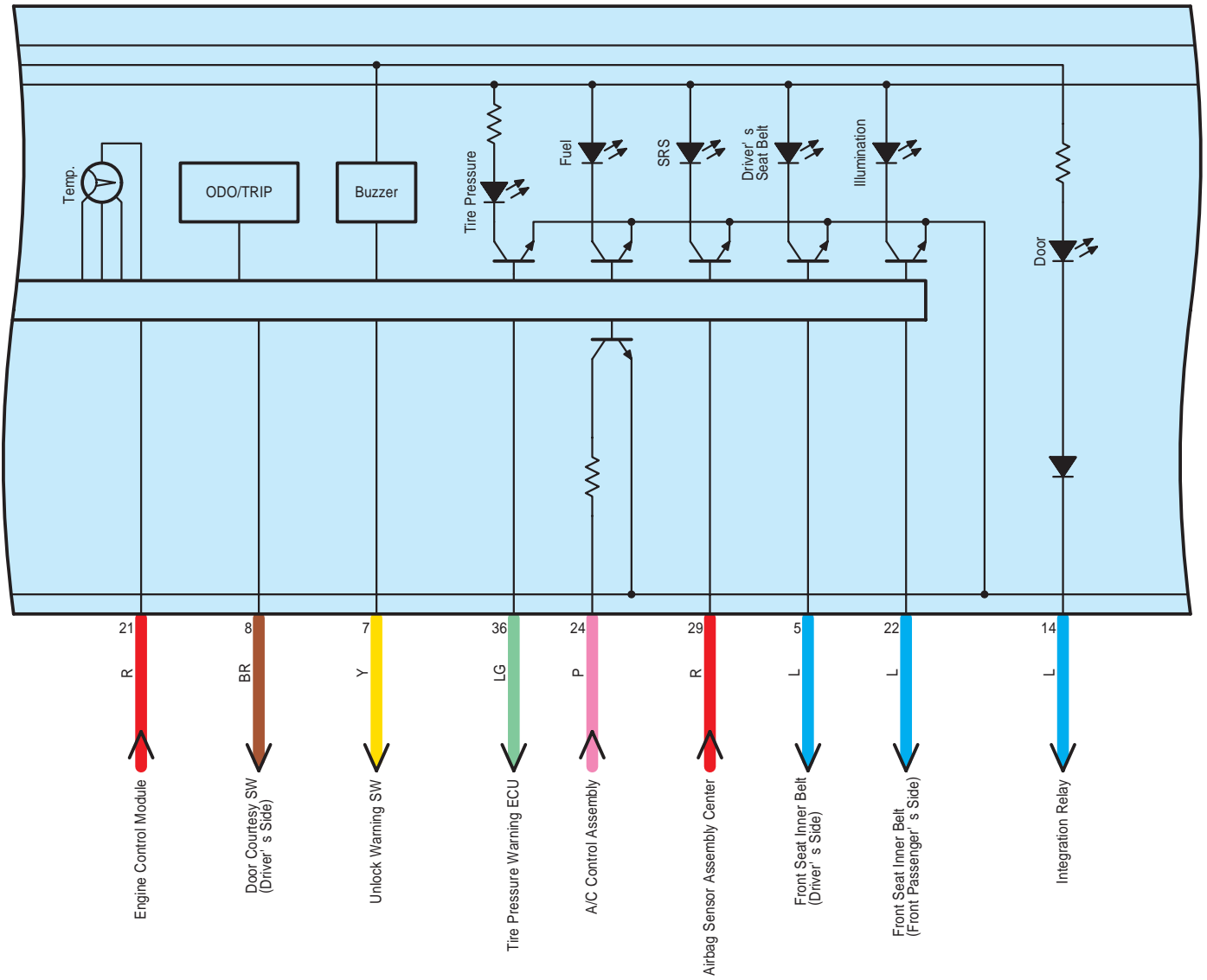

Combination Meter

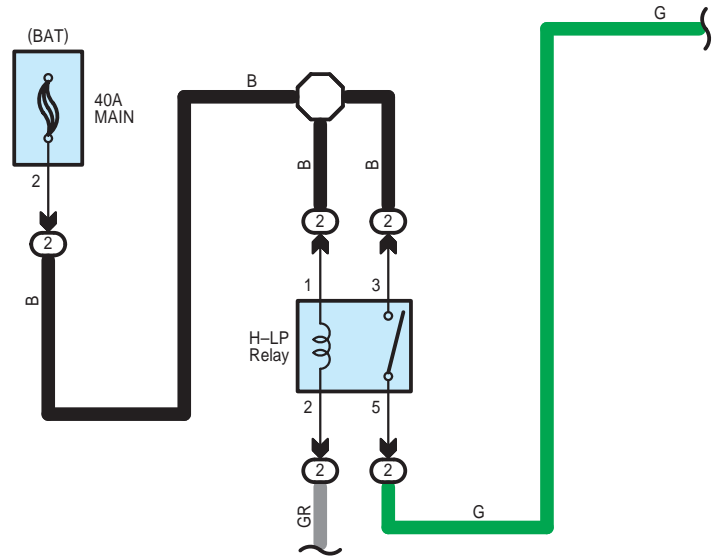

C 6
Combination Meter

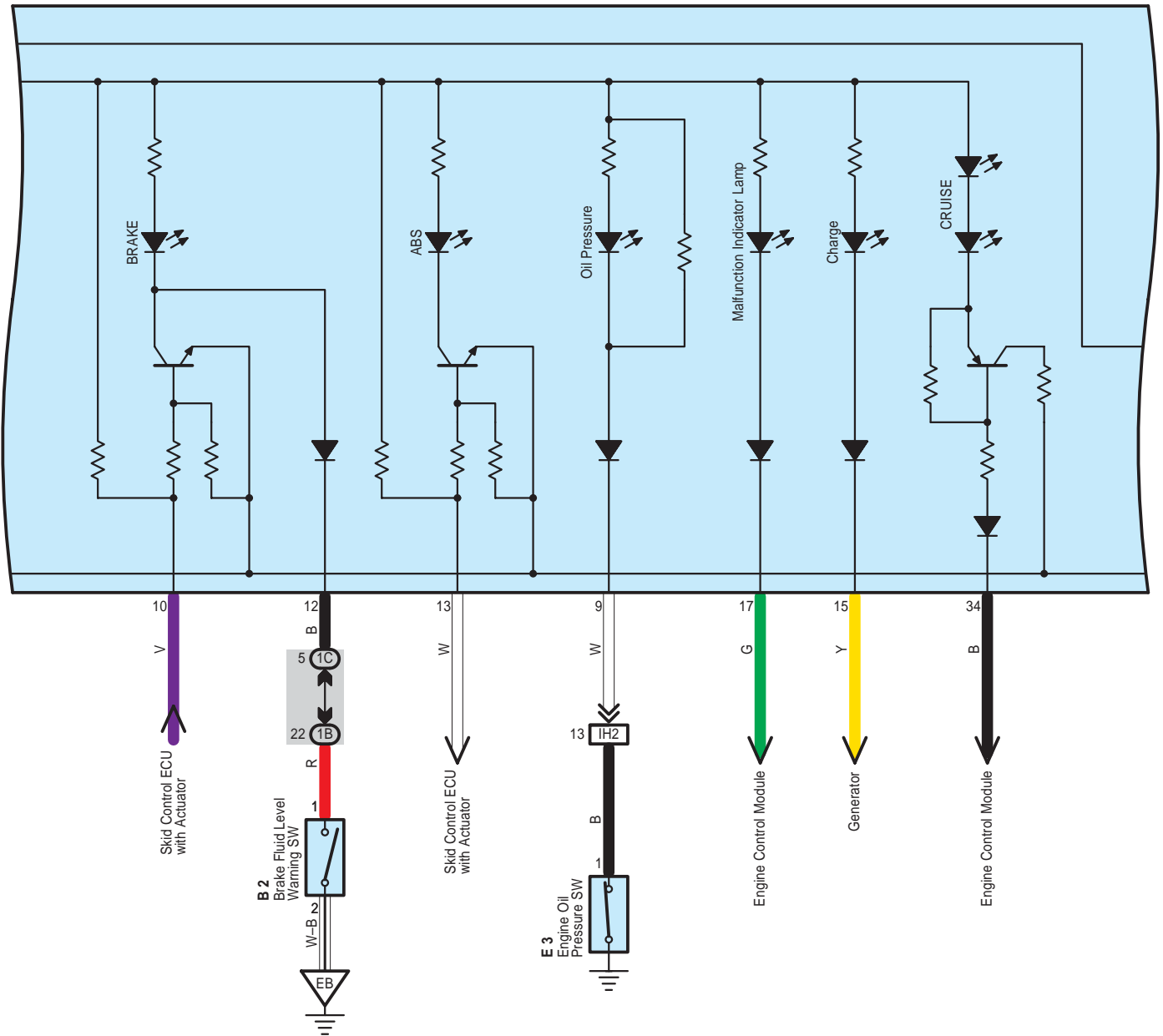

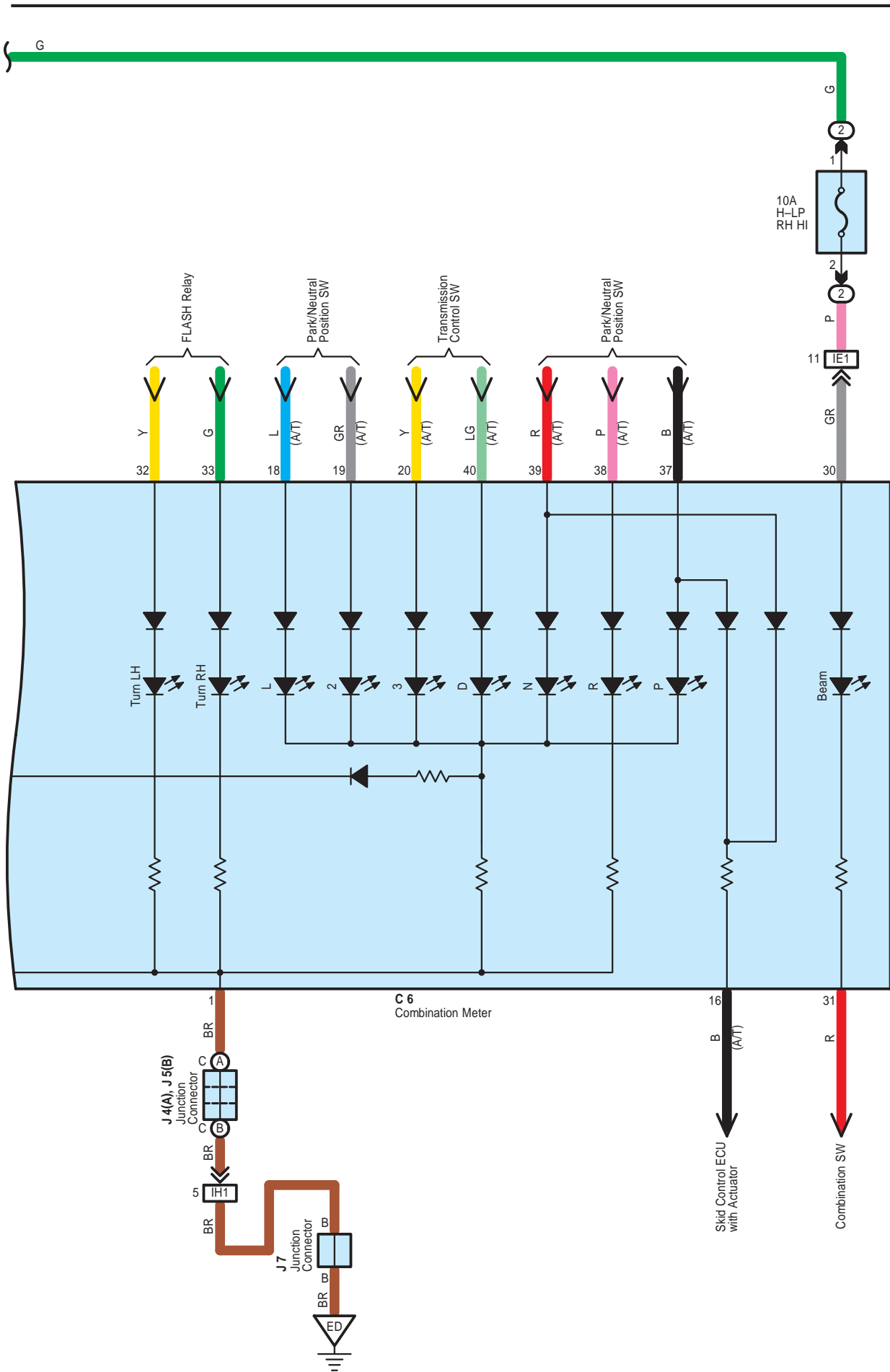

Combination Meter

: Parts Location

| Code | See Page | Code | See Page | Code | See Page | | |
|------|----------|------|----------|------|----------|---|----|
| A7 | A | 36 | E5 | 36 | J5 | B | 37 |
| | B | 36 | F9 | 38 | J7 | | 37 |
| B2 | 34 | J1 | A | 37 | R9 | | 37 |
| C6 | 36 | J2 | B | 37 | S13 | | 39 |
| E3 | 34 | J4 | A | 37 | T11 | | 37 |

: Relay Blocks

| Code | See Page | Relay Blocks (Relay Block Location) |
|------|----------|---|
| 2 | 22 | Engine Room R/B (Engine Compartment Left) |

: Junction Block and Wire Harness Connector

| Code | See Page | Junction Block and Wire Harness (Connector Location) |
|------|----------|---|
| 1A | 24 | Floor Wire and Instrument Panel J/B (Lower Finish Panel) |
| 1B | 24 | Engine Room Main Wire and Instrument Panel J/B (Lower Finish Panel) |
| 1C | 24 | Instrument Panel Wire and Instrument Panel J/B (Lower Finish Panel) |
| 1D | | |
| 1E | | |
| 1G | 24 | Engine Room Main Wire and Instrument Panel J/B (Lower Finish Panel) |
| 1M | 25 | Instrument Panel Wire and Instrument Panel J/B (Lower Finish Panel) |
| 1P | | |
| 1S | | |

: Connector Joining Wire Harness and Wire Harness

| Code | See Page | Joining Wire Harness and Wire Harness (Connector Location) |
|------|----------|---|
| IA1 | 42 | Roof Wire and Instrument Panel Wire (Cowl Top Side Panel LH) |
| IC2 | 42 | Floor Wire and Instrument Panel Wire (Left Kick Panel) |
| IE1 | 42 | Engine Room Main Wire and Instrument Panel Wire (Behind of the Combination Meter) |
| IH1 | 43 | Engine Wire and Instrument Panel Wire (Cowl Side Panel RH) |
| IH2 | | |

: Ground Points

| Code | See Page | Ground Points Location |
|------|----------|--------------------------------------|
| EB | 40 | Front Right Fender |
| ED | 40 | Front Left Side of the Cylinder Head |

Radiator Fan and Condenser Fan

* 1 : w/ Cruise Control
 * 2 : w/o Cruise Control

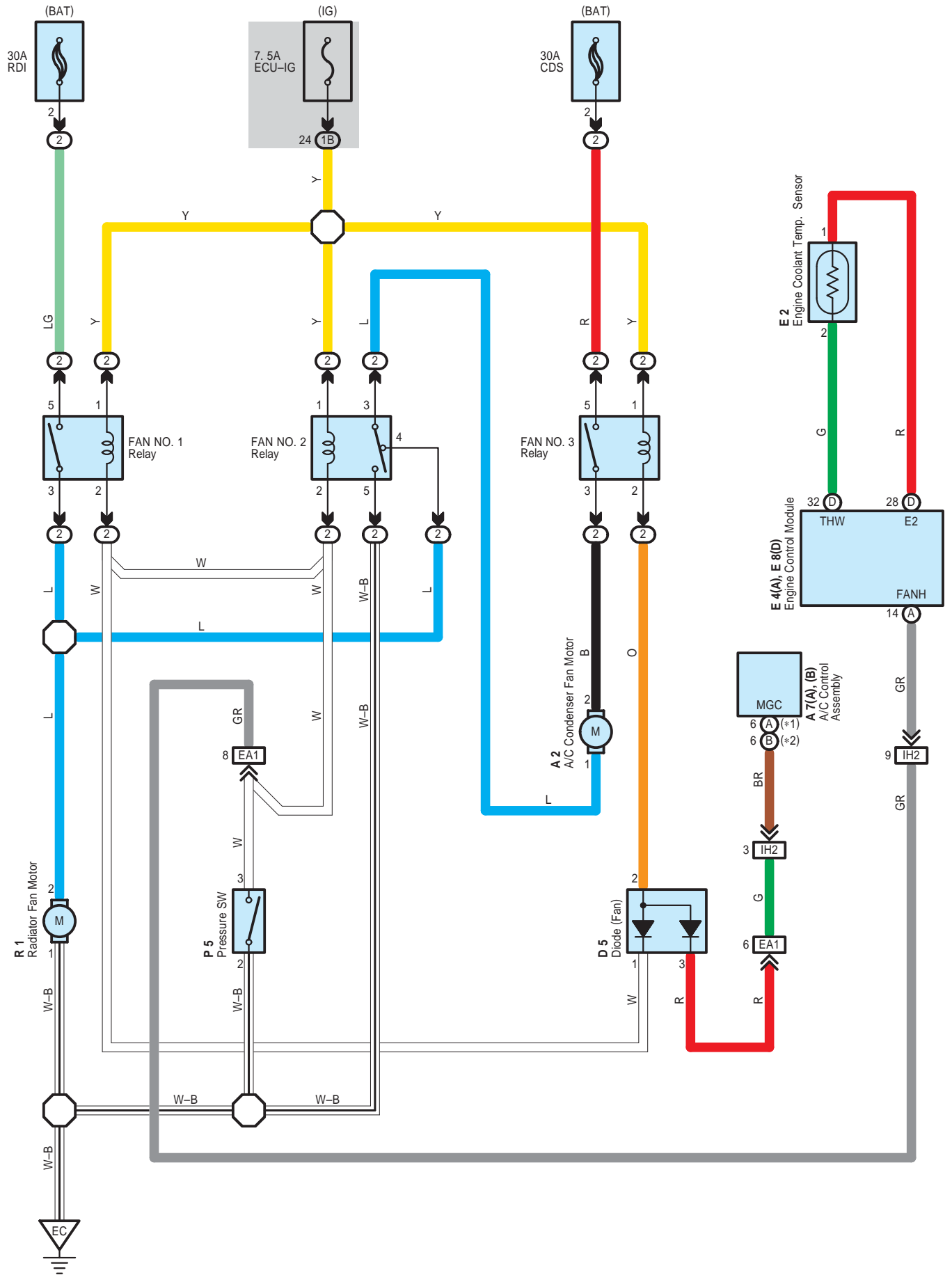

System Outline

Fan Motor Operation

With the ignition SW turned on, the current through the ECU-IG fuse flows to the FAN NO.1 relay (Coil side), FAN NO.2 relay (Coil side) and FAN NO.3 relay (Coil side).

1. Low Speed Operation

Only when the A/C system is activated, the A/C condenser fan motor and the radiator fan motor rotates at low speed.

When the A/C system is activated, the current from ECU-IG fuse flows to the FAN NO.3 relay (Coil side) to TERMINAL 2 of the diode (Fan) to TERMINAL 3 to TERMINAL (B) 2 of the engine control module causing the FAN NO.3 relay to turn on. As a result, the current through the CDS fuse flows to TERMINAL 5 of the FAN NO.3 relay to TERMINAL 3 to TERMINAL 2 of the A/C condenser fan motor to TERMINAL 1 to TERMINAL 3 of the FAN NO.2 relay to TERMINAL 4 to TERMINAL 2 of the radiator fan motor to TERMINAL 1 to GROUND. As this flowing in series for the motors, the motors rotate at low speed.

2. High Speed Operation

With the pressure SW is turned on and/or the engine control module activated, the A/C condenser fan motor and the radiator fan motor rotate at high speed.

When the pressure SW is turned on, the current through the ECU-IG fuse flows to the FAN NO.1 and NO.2 relay (Coil side) to TERMINAL 3 of the pressure SW to TERMINAL 2 to GROUND, and the current through the ECU-IG fuse flows to the FAN NO.3 relay (Coil side) to TERMINAL 2 of the diode (Fan) to TERMINAL 1 to TERMINAL 3 of the pressure SW to TERMINAL 2 to GROUND. As a result, FAN NO.1, NO.2. and NO.3 relay is turned on. At the same time, the current from the RDI fuse flows to FAN NO.1 relay (Point side) to TERMINAL 2 of the radiator fan motor to TERMINAL 1 to GROUND, and the current from the CDS fuse flows to FAN NO.3 relay (Point side) to TERMINAL 2 of the A/C condenser fan motor to TERMINAL 1 to TERMINAL 3 of the FAN NO.2 relay to TERMINAL 5 to GROUND.

As the current flowing in parallel for motors as above, the motors rotate at high speed.

When the engine control module activated, the current through the ECU-IG fuse flows to the FAN NO.1 and NO.2 relay (Coil side) to TERMINAL (E) 14 of the engine control module, and the current through the ECU-IG fuse flows to the FAN NO.3 relay (Coil side) to TERMINAL 2 of the diode (Fan) to TERMINAL 1 to TERMINAL (E) 14 of the engine control module. As a result, FAN NO.1, NO.2 and NO.3 relay is turned on. At the same time, the current from the RDI fuse flows to FAN NO.1 relay (Point side) to TERMINAL 2 of the radiator fan motor to TERMINAL 1 to GROUND, and the current from the CDS fuse flows to FAN NO.3 relay (Point side) to TERMINAL 2 of the A/C condenser fan motor to TERMINAL 1 to TERMINAL 3 of the FAN NO.2 relay to TERMINAL 5 to GROUND.

As the current flowing in parallel for motors as above, the motors rotate at high speed.

○ : Parts Location

| Code | See Page | Code | See Page | Code | See Page |
|------|----------|------|----------|------|----------|
| A2 | 34 | D5 | 36 | E8 | D 36 |
| A7 | A 36 | E2 | 34 | P5 | 35 |
| | B 36 | E4 | A 36 | R1 | 35 |

○ : Relay Blocks

| Code | See Page | Relay Blocks (Relay Block Location) |
|------|----------|---|
| 2 | 22 | Engine Room R/B (Engine Compartment Left) |

○ : Junction Block and Wire Harness Connector

| Code | See Page | Junction Block and Wire Harness (Connector Location) |
|------|----------|---|
| 1B | 24 | Engine Room Main Wire and Instrument Panel J/B (Lower Finish Panel) |

□ : Connector Joining Wire Harness and Wire Harness

| Code | See Page | Joining Wire Harness and Wire Harness (Connector Location) |
|------|----------|---|
| EA1 | 40 | Engine Wire and Engine Room Main Wire (Inside of the Engine Room R/B Box) |
| IH2 | 43 | Engine Wire and Instrument Panel Wire (Cowl Side Panel RH) |

▽ : Ground Points

| Code | See Page | Ground Points Location |
|------|----------|------------------------|
| EC | 40 | Front Left Fender |

Air Conditioning

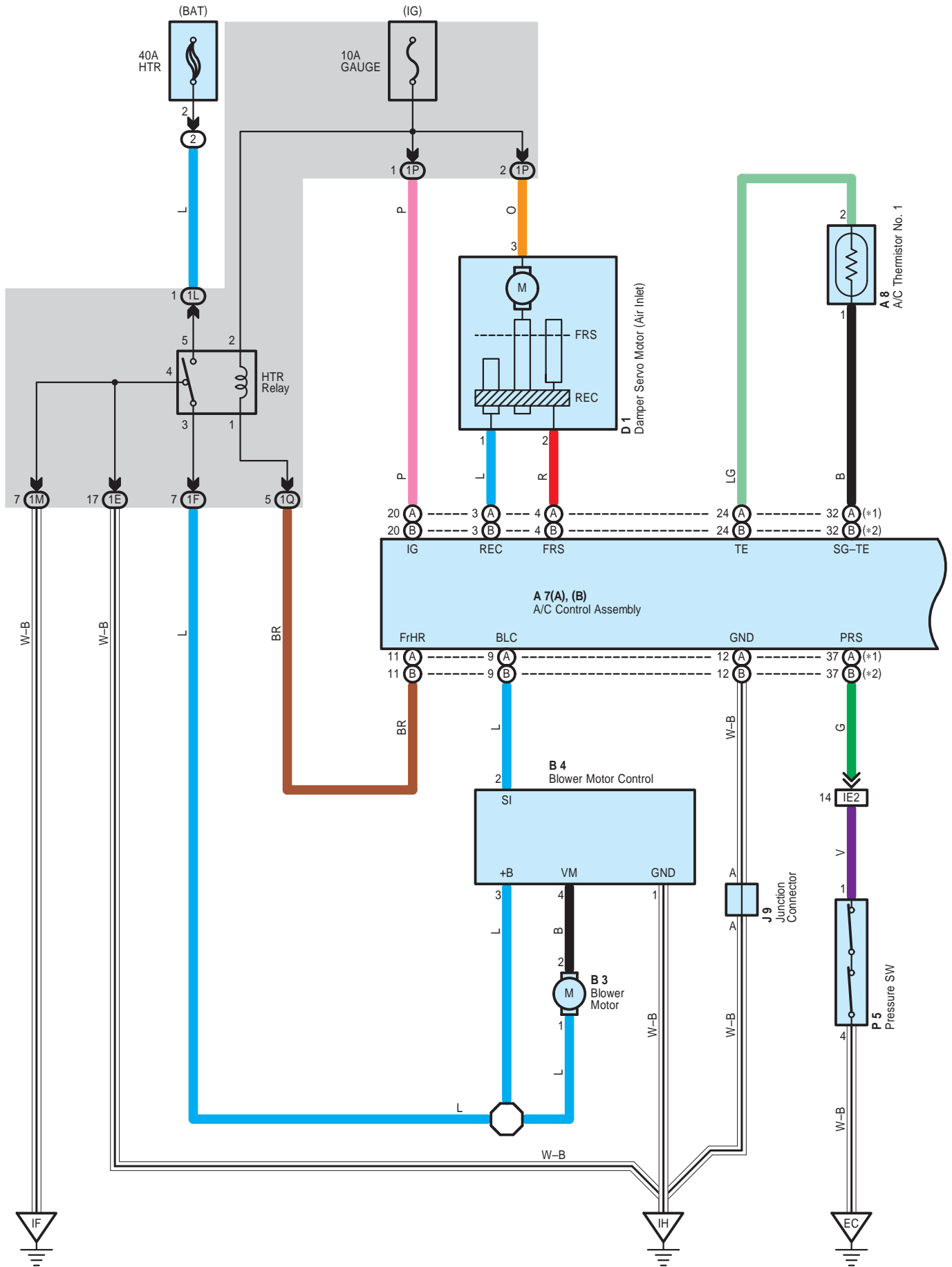

* 1 : w/ Cruise Control
 * 2 : w/o Cruise Control

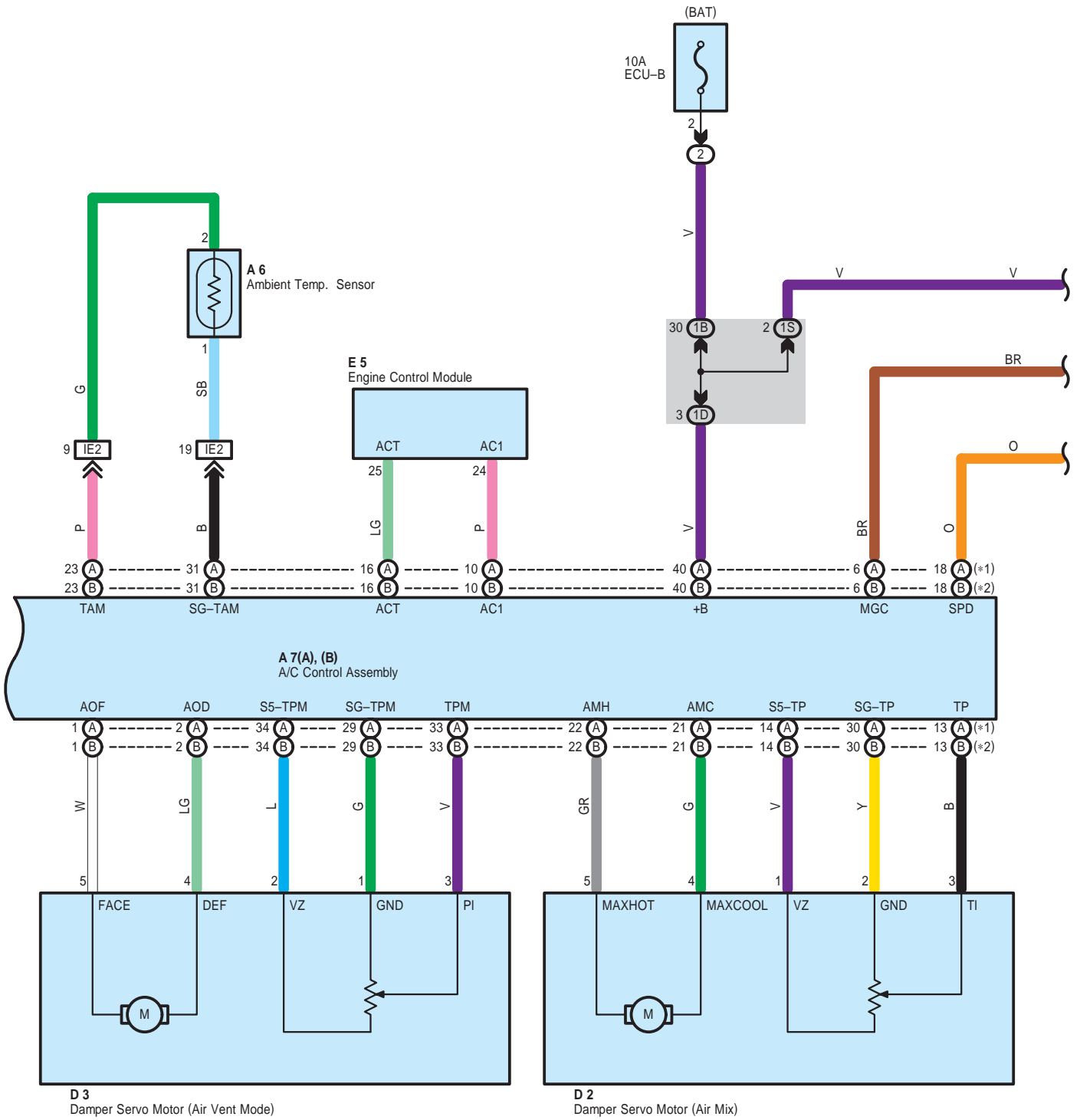

Air Conditioning

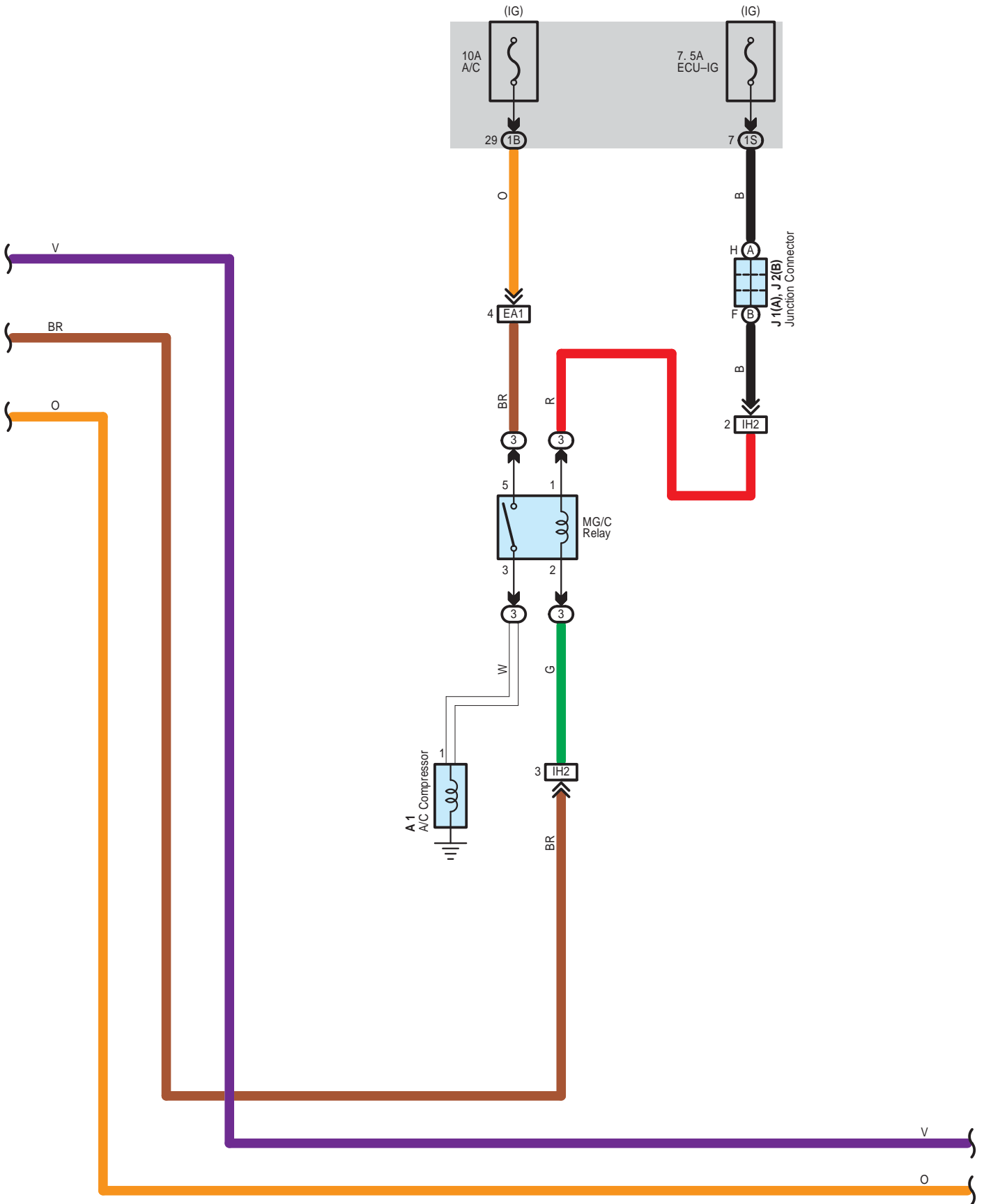

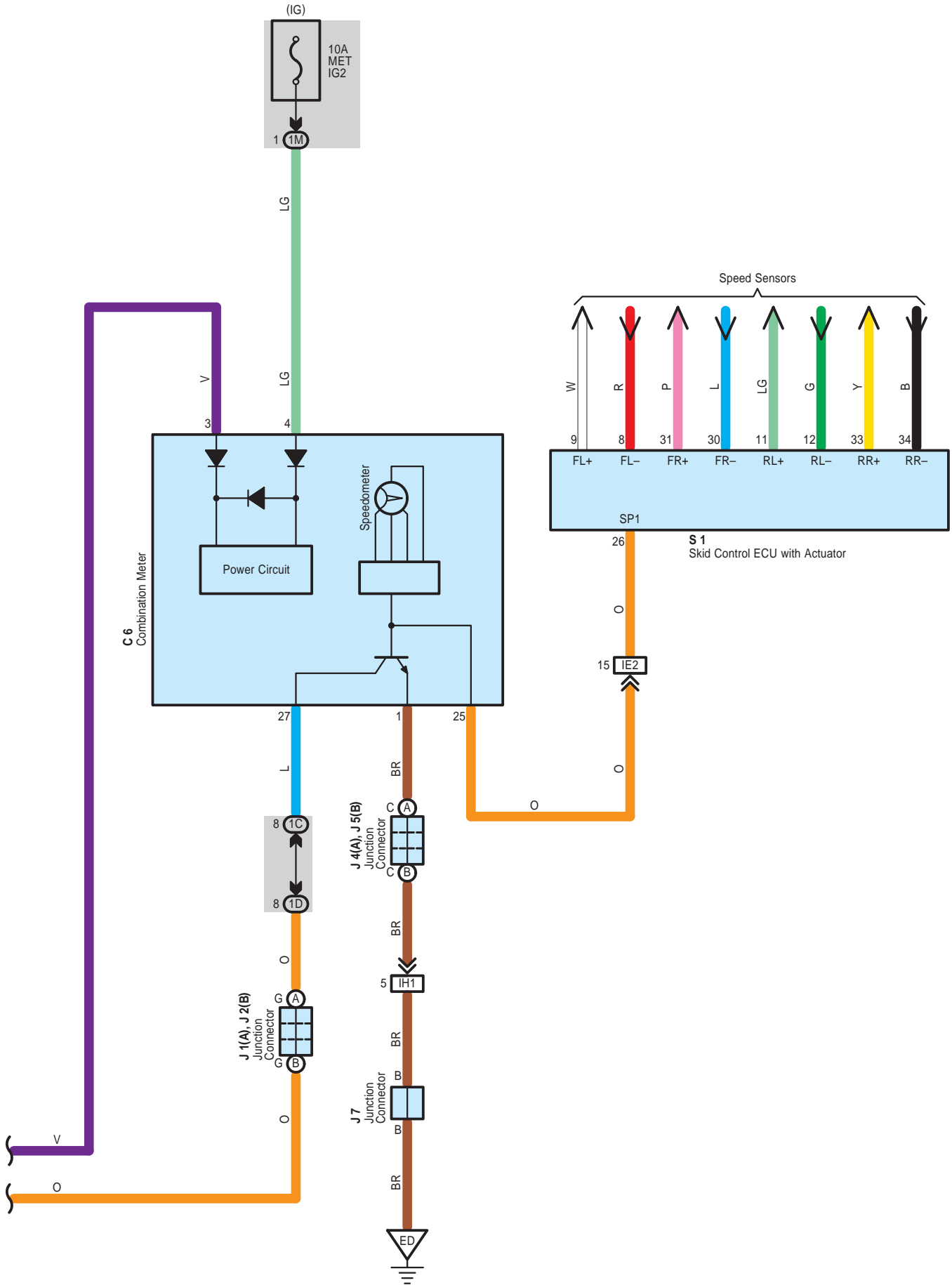

Air Conditioning

System Outline

1. Heater Blower Operation

When the blower speed is set to a certain level using the blower control SW, the A/C control assembly sends the signals to the blower control to control the blower motor speed.

2. Damper Servo Motor (Air Inlet) Control

When the FRESH/RECIRC select SW is set to RECIRC, the motor in the damper servo motor (Air inlet) starts rotating to move the damper toward the RECIRC side. Since the damper position is detected by the TERMINAL REC of the A/C control assembly, the motor is continuously rotated until the damper reaches its stop position. When the FRESH/RECIRC select SW is set to FRESH, the motor in the air inlet control servo motor starts rotating to move the damper toward the FRESH side. Since the damper position is detected by the TERMINAL FRS of the A/C control assembly, the motor is continuously rotated until the damper reaches its stop position.

3. Damper Servo Motor (Air Vent Mode) Control

When the mode select SW is pushed, the ECU in the A/C control assembly activates the damper servo motor (Air vent mode). This causes the servo motor to rotate to the position (FACE, BI-LEVEL, FOOT, FOOT/DEF, DEF) selected using the mode select SW, and moves the damper.

4. Damper Servo Motor (Air Mix) Control

When the temperature control SW is pressed, the ECU in the A/C control assembly sends a signal to the damper servo motor (Air mix). This signal drives the motor to reach the temperature set by the temperature control SW, and moves the damper.

5. Air Conditioning Operation

The A/C control assembly receives various signals, I.E., the engine RPM from the engine control module, outside air temperature signal from the ambient temp. sensor and coolant temperature from the engine control module, etc.

When the engine is started and the A/C SW (A/C control assembly) is on, a signal is input to the engine control module.

As a result, the ground circuit in engine control module is closed and current flows from ECU-IG fuse to TERMINAL 1 of the MG/C relay to TERMINAL 2 to TERMINAL ACMG of the engine control module, turning the MG/C relay on, so that the magnetic clutch is on and the A/C compressor operates.

At the same time, the A/C control assembly detects the magnetic clutch is on and the A/C compressor operates.

If the A/C control assembly detects the following conditions, it stops the air conditioning:

- * Evaporator outlet air is too low.
- * There is a marked difference between the compressor speed and the engine speed.
- * The refrigerant pressure is abnormally high or abnormally low.
- * The engine speed is too low.
- * Rapid acceleration occurs.

6. DEF Synchronized Control Function

When the blower SW is on and the air vent mode control SW turned to DEF or FOOT DEF position, it causes A/C to run whether A/C SW is on or not.

○ : Parts Location

| Code | See Page | Code | See Page | Code | See Page |
|------|----------|--------|----------|--------|----------|
| A1 | 34 | C6 | 36 | J4 A | 37 |
| A6 | 34 | D1 | 36 | J5 B | 37 |
| A7 | A 36 | D2 | 36 | J7 | 37 |
| | B 36 | D3 | 36 | J9 | 37 |
| A8 | 36 | E5 | 36 | P5 | 35 |
| B3 | 36 | J1 A | 37 | S1 | 35 |
| B4 | 36 | J2 B | 37 | | |

○ : Relay Blocks

| Code | See Page | Relay Blocks (Relay Block Location) |
|------|----------|--|
| 2 | 22 | Engine Room R/B (Engine Compartment Left) |
| 3 | 23 | Engine Room R/B No.2 (Inside of the Engine Room R/B Box) |

 : **Junction Block and Wire Harness Connector**

| Code | See Page | Junction Block and Wire Harness (Connector Location) |
|------|----------|---|
| 1B | 24 | Engine Room Main Wire and Instrument Panel J/B (Lower Finish Panel) |
| 1C | 24 | Instrument Panel Wire and Instrument Panel J/B (Lower Finish Panel) |
| 1D | | |
| 1E | | |
| 1F | | |
| 1L | | |
| 1M | 24 | Engine Room Main Wire and Instrument Panel J/B (Lower Finish Panel) |
| 1P | 25 | Instrument Panel Wire and Instrument Panel J/B (Lower Finish Panel) |
| 1Q | | |
| 1S | | |

 : **Connector Joining Wire Harness and Wire Harness**

| Code | See Page | Joining Wire Harness and Wire Harness (Connector Location) |
|------|----------|---|
| EA1 | 40 | Engine Wire and Engine Room Main Wire (Inside of the Engine Room R/B Box) |
| IE2 | 42 | Engine Room Main Wire and Instrument Panel Wire (Behind of the Combination Meter) |
| IH1 | 43 | Engine Wire and Instrument Panel Wire (Cowl Side Panel RH) |
| IH2 | | |

 : **Ground Points**

| Code | See Page | Ground Points Location |
|------|----------|--------------------------------------|
| EC | 40 | Front Left Fender |
| ED | 40 | Front Left Side of the Cylinder Head |
| IF | 42 | Cowl Brace LH |
| IH | 42 | Cowl Brace RH |

I GROUND POINT

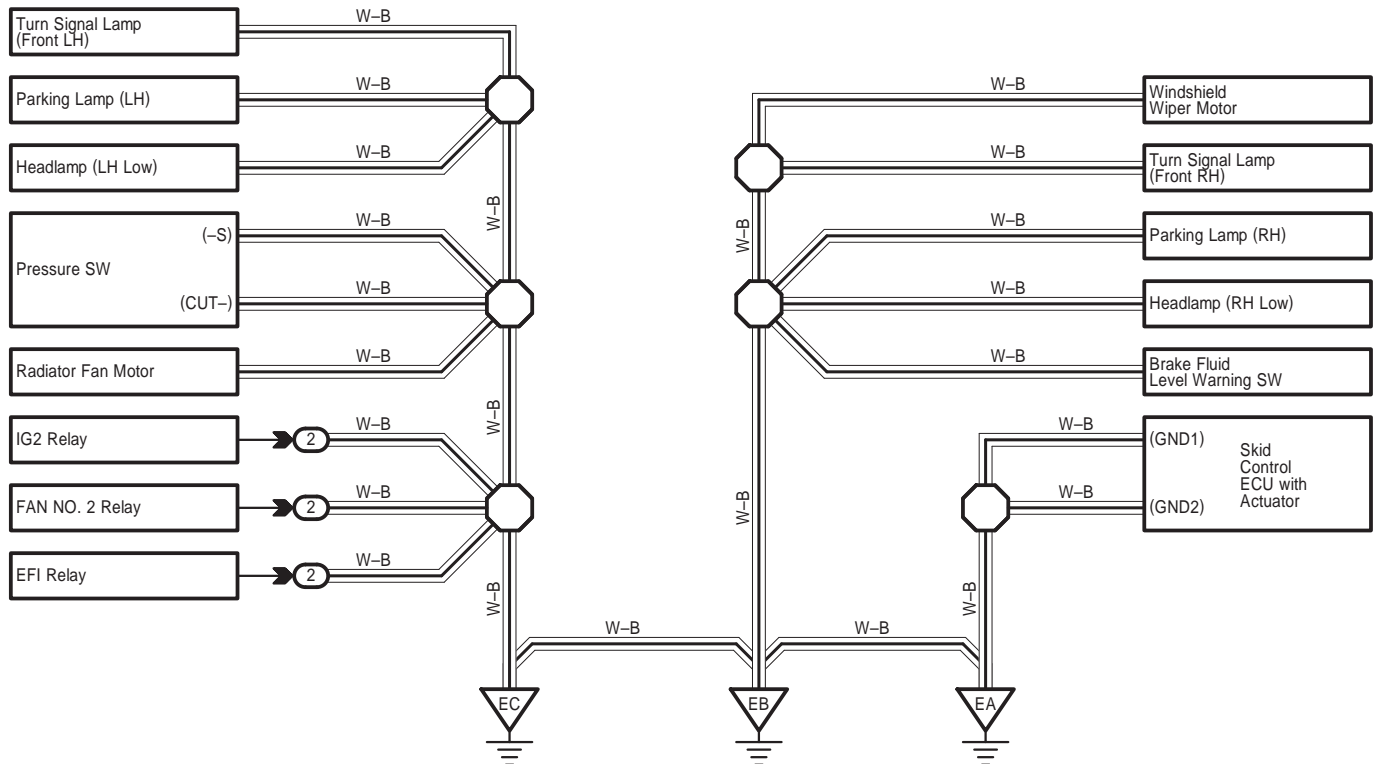
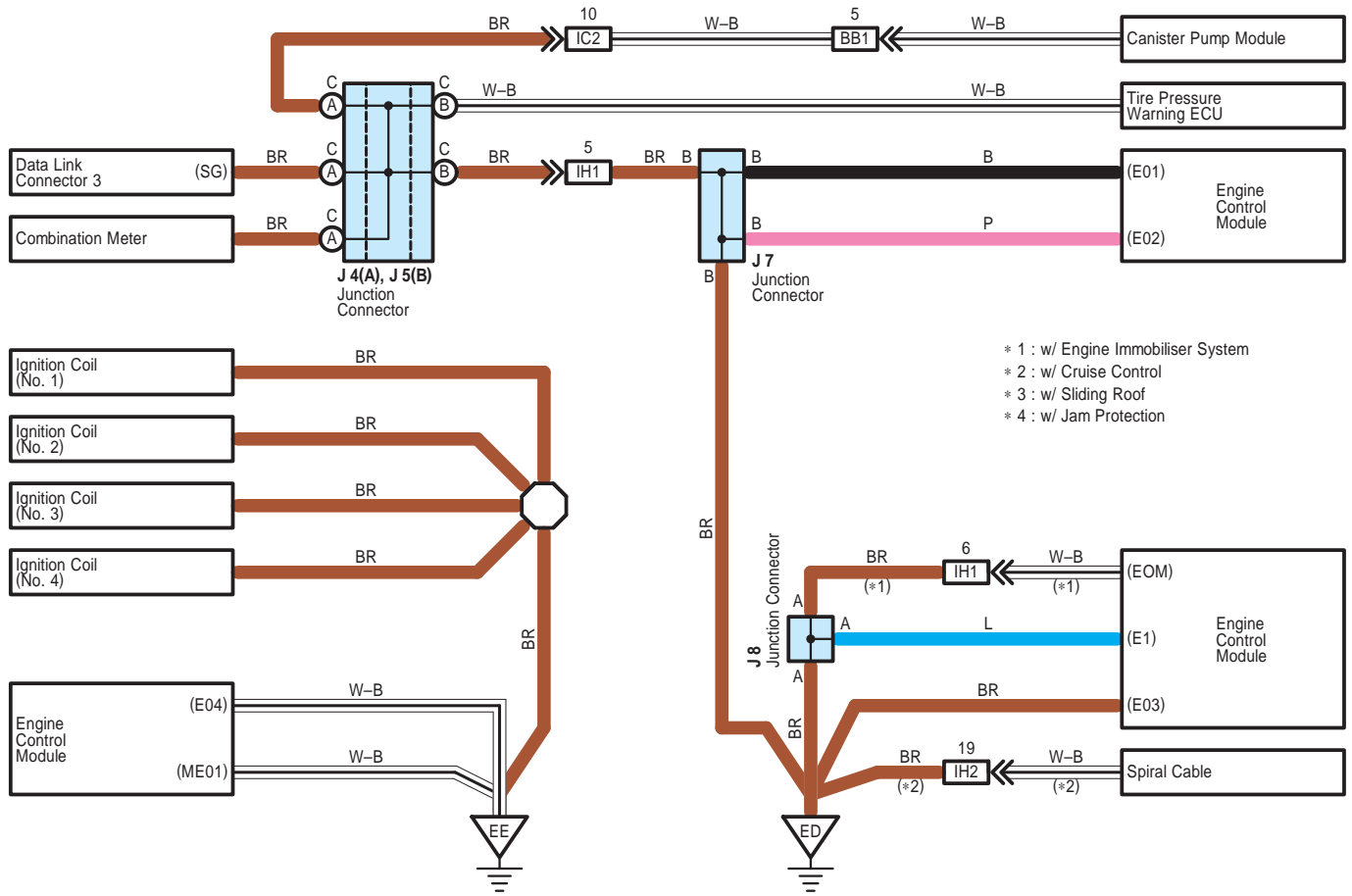

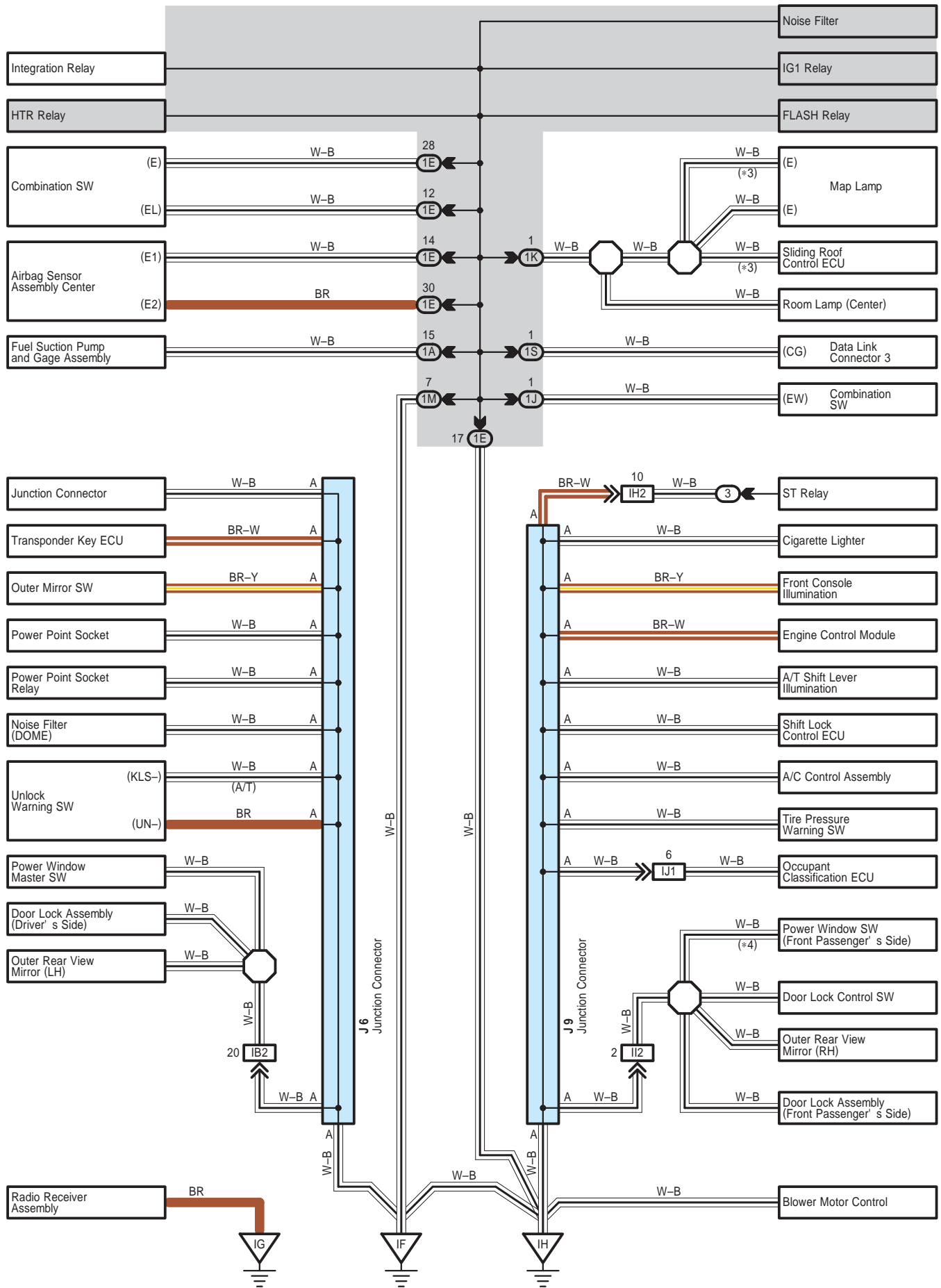

SCION tC (EM0300U)

I GROUND POINT

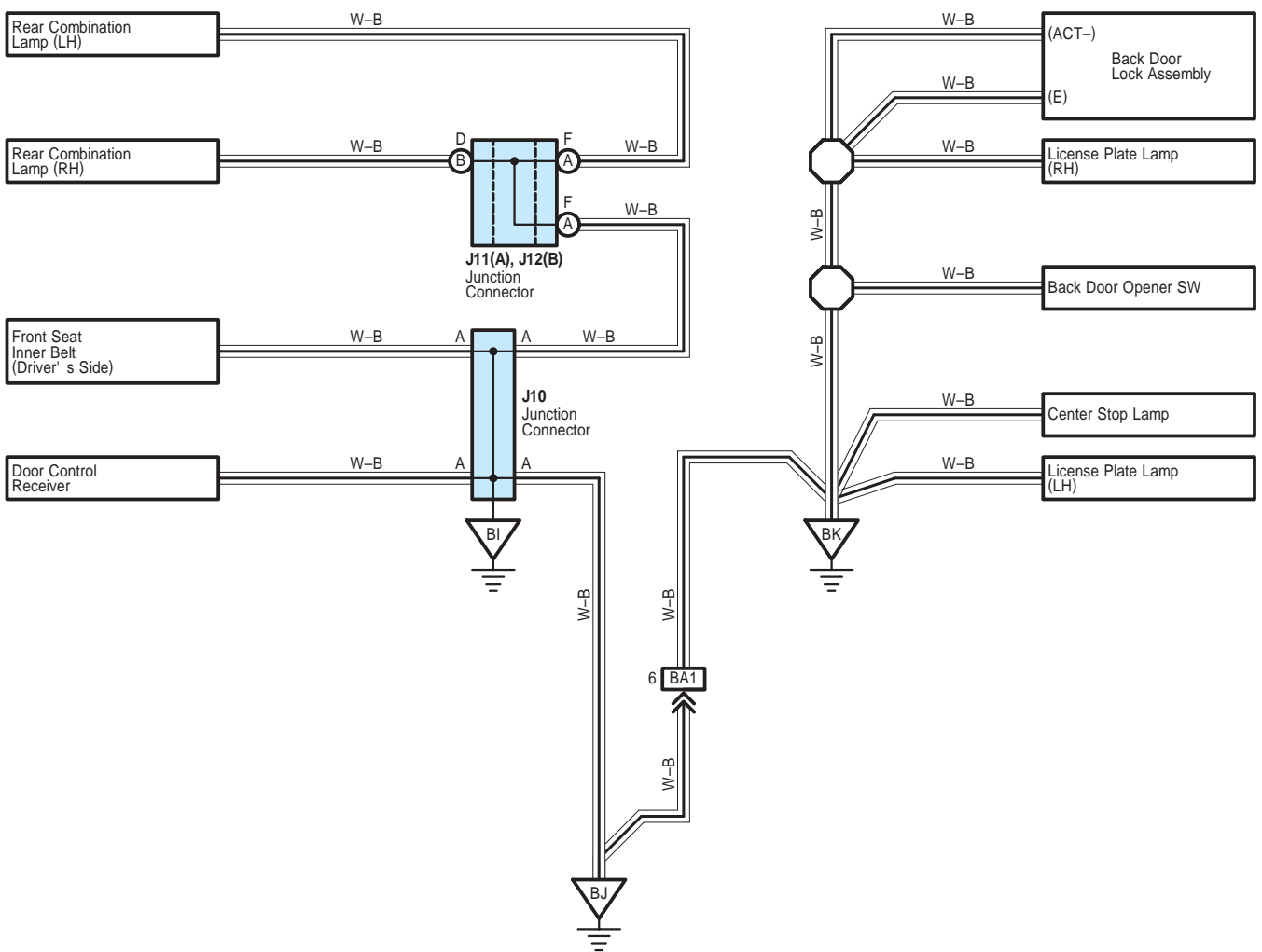

○ : Parts Location

| Code | | See Page | Code | | See Page | Code | | See Page |
|------|---|----------|------|----|----------|------|----|----------|
| J4 | A | 37 | J7 | 37 | J10 | | 38 | |
| J5 | B | 37 | J8 | 37 | J11 | A | 38 | |
| J6 | | 37 | J9 | 37 | J12 | B | 38 | |

○ : Relay Blocks

| Code | See Page | Relay Blocks (Relay Block Location) |
|------|----------|--|
| 2 | 22 | Engine Room R/B (Engine Compartment Left) |
| 3 | 23 | Engine Room R/B No.2 (Inside of the Engine Room R/B Box) |

○ : Junction Block and Wire Harness Connector

| Code | See Page | Junction Block and Wire Harness (Connector Location) |
|------|----------|---|
| 1A | 24 | Floor Wire and Instrument Panel J/B (Lower Finish Panel) |
| 1E | 24 | Instrument Panel Wire and Instrument Panel J/B (Lower Finish Panel) |
| 1J | | |
| 1K | 24 | Roof Wire and Instrument Panel J/B (Lower Finish Panel) |
| 1M | 25 | Instrument Panel Wire and Instrument Panel J/B (Lower Finish Panel) |
| 1S | | |

□ : Connector Joining Wire Harness and Wire Harness

| Code | See Page | Joining Wire Harness and Wire Harness (Connector Location) |
|------|----------|---|
| IB2 | 42 | Front Door LH Wire and Instrument Panel Wire (Left Kick Panel) |
| IC2 | 42 | Floor Wire and Instrument Panel Wire (Left Kick Panel) |
| IH1 | 43 | Engine Wire and Instrument Panel Wire (Cowl Side Panel RH) |
| IH2 | | |
| II2 | 43 | Front Door RH Wire and Instrument Panel Wire (Right Kick Panel) |
| IJ1 | 43 | Floor No.2 Wire and Instrument Panel Wire (Right Kick Panel) |
| BA1 | 44 | Back Door No.1 Wire and Floor Wire (Back Window Upper Frame LH) |
| BB1 | 44 | Floor Wire and Floor No.3 Wire (Center Floor Pan Center) |

▽ : Ground Points

| Code | See Page | Ground Points Location |
|------|----------|--------------------------------------|
| EA | 40 | Front Right Fender |
| EB | | |
| EC | 40 | Front Left Fender |
| ED | 40 | Front Left Side of the Cylinder Head |
| EE | 40 | Left Side of the Cylinder Head |
| IF | 42 | Cowl Brace LH |
| IG | 42 | Instrument Panel Brace LH |
| IH | 42 | Cowl Brace RH |
| BI | 44 | Quarter Panel LH |
| BJ | | |
| BK | 44 | Left Side of the Back Door Panel |

J POWER SOURCE (Current Flow Chart)

The chart below shows the route by which current flows from the battery to each electrical source (Fusible Link, Circuit Breaker, Fuse, etc.) and other Parts.

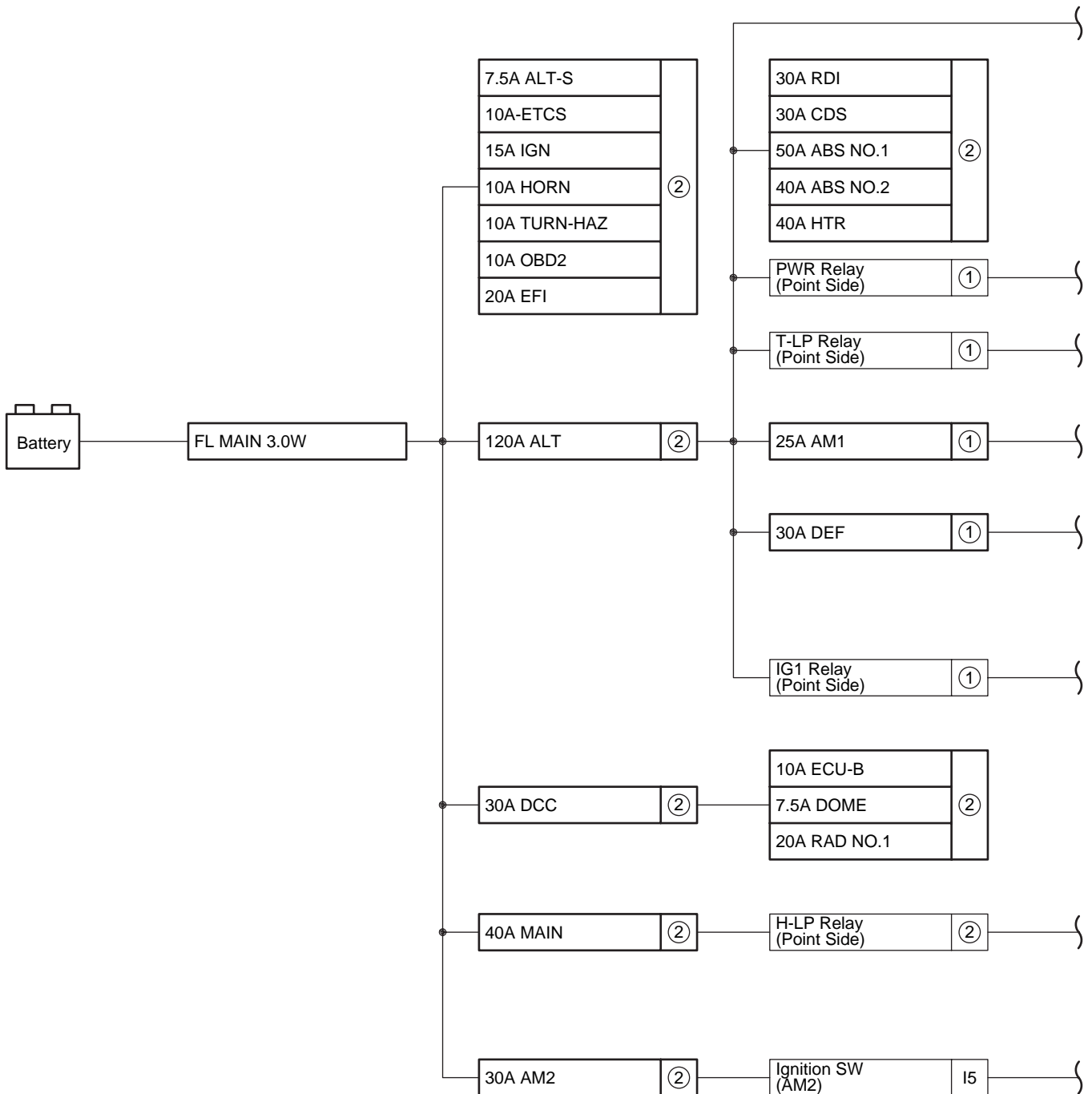

[LOCATION]

- ① : Instrument Panel J/B (See Page 24)
- ② : Engine Room R/B and Engine Room J/B (See Page 22)
- ③ : Engine Room R/B No.2 (See Page 23)

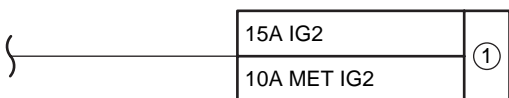
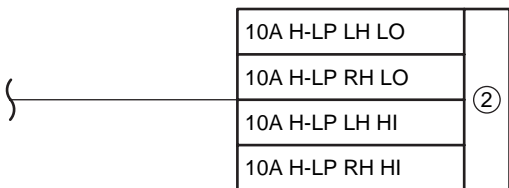
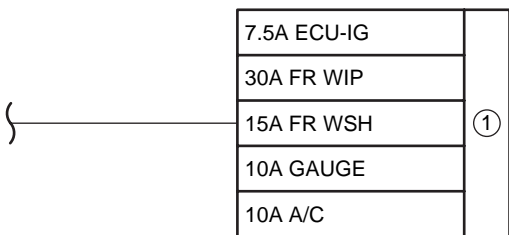
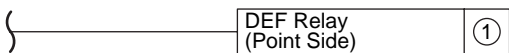
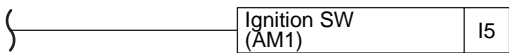
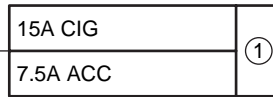
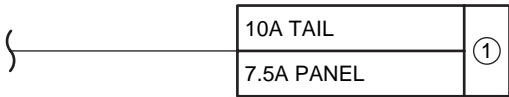
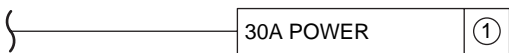
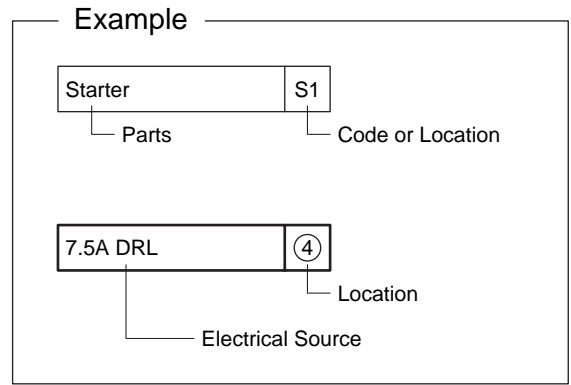
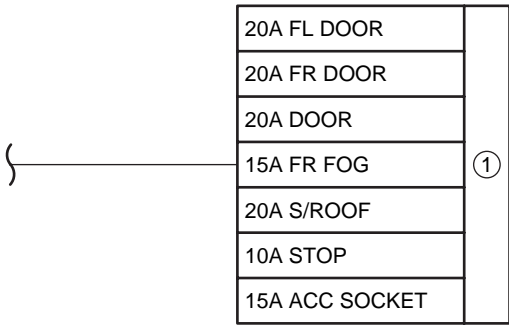

J POWER SOURCE (Current Flow Chart)

Instrument Panel J/B (See Page 24)

| Fuse | | System | Page |
|--------------------------------------|-------------|--|------|
| 7.5A | ACC | Audio System | 166 |
| | | Power Outlet | 156 |
| | | Remote Control Mirror | 94 |
| | | Shift Lock | 122 |
| 7.5A | ECU-IG | ABS | 136 |
| | | Air Conditioning | 178 |
| | | Back Door Opener | 114 |
| | | Charging | 54 |
| | | Cruise Control | 130 |
| | | Door Lock Control | 104 |
| | | Interior Light | 78 |
| | | Power Window (w/ Jam Protection) | 96 |
| | | Radiator Fan and Condenser Fan | 176 |
| | | Shift Lock | 122 |
| | | Sliding Roof | 118 |
| | | Tire Pressure Warning System | 142 |
| Wireless Door Lock Control | 108 | | |
| 7.5A | PANEL | Combination Meter | 170 |
| | | Illumination | 82 |
| | | Light Reminder | 160 |
| 7.5A | RR DEF I/UP | Engine Control | 56 |
| 10A | A/C | Air Conditioning | 178 |
| 10A | GAUGE | ABS | 136 |
| | | Air Conditioning | 178 |
| | | Back-Up Light | 90 |
| | | Cruise Control | 130 |
| | | Electronically Controlled Transmission and A/T Indicator | 124 |
| | | Engine Control | 56 |
| | | Illumination | 82 |
| | | Power Window (w/ Jam Protection) | 96 |
| | | Rear Window Defogger | 164 |
| | | Seat Belt Warning | 162 |
| | | SRS | 145 |
| Turn Signal and Hazard Warning Light | 74 | | |
| 10A | MET IG2 | ABS | 136 |
| | | Air Conditioning | 178 |
| | | Audio System | 166 |
| | | Back Door Opener | 114 |
| | | Charging | 54 |
| | | Combination Meter | 170 |
| | | Cruise Control | 130 |
| | | Electronically Controlled Transmission and A/T Indicator | 124 |

* These are the page numbers of the first page on which the related system is shown.

| Fuse | | System | Page |
|------|------------|--|------|
| 10A | MET IG2 | Engine Control | 56 |
| | | Illumination | 82 |
| | | Key Reminder | 158 |
| | | Light Reminder | 160 |
| | | Seat Belt Warning | 162 |
| | | Sliding Roof | 118 |
| | | SRS | 145 |
| | | Tire Pressure Warning System | 142 |
| 10A | STOP | ABS | 136 |
| | | Cruise Control | 130 |
| | | Electronically Controlled Transmission and A/T Indicator | 124 |
| | | Engine Control | 56 |
| | | Shift Lock | 122 |
| | | Stop Light | 88 |
| 10A | TAIL | Engine Control | 56 |
| | | Taillight | 86 |
| 15A | ACC SOCKET | Power Outlet | 156 |
| 15A | CIG | Cigarette Lighter | 154 |
| 15A | FR WSH | Front Wiper and Washer | 92 |
| 15A | IG2 | Cruise Control | 130 |
| | | Electronically Controlled Transmission and A/T Indicator | 124 |
| | | Engine Control | 56 |
| | | Engine Immobiliser System | 66 |
| | | Ignition | 52 |
| | | SRS | 145 |
| 20A | DOOR | Back Door Opener | 114 |
| | | Door Lock Control | 104 |
| | | Power Window (w/ Jam Protection) | 96 |
| | | Sliding Roof | 118 |
| | | Wireless Door Lock Control | 108 |
| 20A | FL DOOR | Power Window (w/ Jam Protection) | 96 |
| 20A | FR DOOR | Power Window (w/ Jam Protection) | 96 |
| 20A | S/ROOF | Sliding Roof | 118 |
| 25A | AM1 | Starting | 50 |
| 30A | DEF | Engine Control | 56 |
| | | Rear Window Defogger | 164 |
| 30A | FR WIP | Front Wiper and Washer | 92 |
| 30A | POWER | Power Window (w/o Jam Protection) | 102 |

Engine Room R/B and Engine Room J/B (See Page 22)

| Fuse | | System | Page |
|------|-------|----------|------|
| 7.5A | ALT-S | Charging | 54 |

* These are the page numbers of the first page on which the related system is shown.

J POWER SOURCE (Current Flow Chart)

| Fuse | | System | Page |
|------------------------------|------------|--|------|
| 7.5A | DOME | Interior Light | 78 |
| | | Wireless Door Lock Control | 108 |
| 10A | ECU-B | ABS | 136 |
| | | Air Conditioning | 178 |
| | | Audio System | 166 |
| | | Back Door Opener | 114 |
| | | Combination Meter | 170 |
| | | Cruise Control | 130 |
| | | Door Lock Control | 104 |
| | | Electronically Controlled Transmission and A/T Indicator | 124 |
| | | Engine Control | 56 |
| | | Engine Immobiliser System | 66 |
| | | Illumination | 82 |
| | | Interior Light | 78 |
| | | Key Reminder | 158 |
| | | Light Reminder | 160 |
| | | Power Window (w/ Jam Protection) | 96 |
| | | Seat Belt Warning | 162 |
| Sliding Roof | 118 | | |
| SRS | 145 | | |
| Tire Pressure Warning System | 142 | | |
| Wireless Door Lock Control | 108 | | |
| 10A | ETCS | Cruise Control | 130 |
| | | Electronically Controlled Transmission and A/T Indicator | 124 |
| | | Engine Control | 56 |
| 10A | H-LP LH HI | Headlight | 72 |
| 10A | H-LP LH LO | Headlight | 72 |
| 10A | H-LP RH HI | Combination Meter | 170 |
| | | Headlight | 72 |
| 10A | H-LP RH LO | Headlight | 72 |
| 10A | HORN | Horn | 152 |
| | | Wireless Door Lock Control | 108 |
| 10A | OBD2 | Engine Control | 56 |
| 10A | TURN-HAZ | Turn Signal and Hazard Warning Light | 74 |
| 15A | IGN | Engine Control | 56 |
| | | Ignition | 52 |
| 20A | EFI | Cruise Control | 130 |
| | | Electronically Controlled Transmission and A/T Indicator | 124 |
| | | Engine Control | 56 |
| | | Engine Immobiliser System | 66 |
| 20A | RAD NO.1 | Audio System | 166 |
| 30A | AM2 | Starting | 50 |
| 30A | CDS | Radiator Fan and Condenser Fan | 176 |

* These are the page numbers of the first page on which the related system is shown.

| Fuse | | System | Page |
|----------------------------|----------|--------------------------------|------|
| 30A | RDI | Radiator Fan and Condenser Fan | 176 |
| 40A | ABS NO.2 | ABS | 136 |
| 40A | HTR | Air Conditioning | 178 |
| 40A | MAIN | Combination Meter | 170 |
| | | Headlight | 72 |
| | | Wireless Door Lock Control | 108 |
| 50A | ABS NO.1 | ABS | 136 |
| 120A | ALT | Charging | 54 |
| | | Combination Meter | 170 |
| | | Engine Control | 56 |
| | | Illumination | 82 |
| | | Light Reminder | 160 |
| | | Starting | 50 |
| | | Taillight | 86 |
| Wireless Door Lock Control | 108 | | |

Engine Room R/B No.2 (See Page 23)

| Fuse | | System | Page |
|------|----|--|------|
| 7.5A | ST | Electronically Controlled Transmission and A/T Indicator | 124 |
| | | Engine Control | 56 |
| | | Starting | 50 |

* These are the page numbers of the first page on which the related system is shown.

K CONNECTOR LIST

*1 : w/ Cruise Control

*2 : w/o Cruise Control

A 1
Gray



A 2
Black



A 3
Dark Gray



A 4
Yellow



A 5
Yellow



A 6
Black



A 7
(*1)

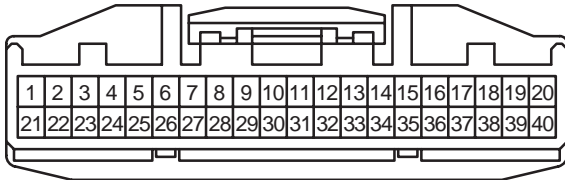

A 7
(*2) Black

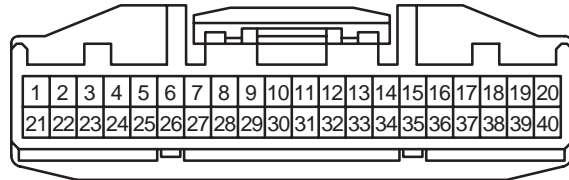

A 8



A 9



A 10
Black



A 11
Yellow

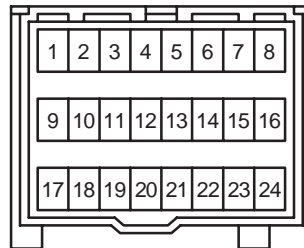

A 12
Yellow

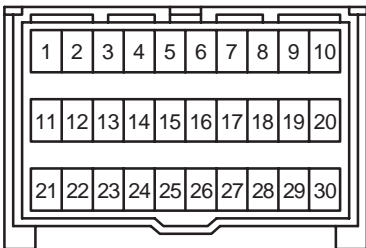

A 13
Yellow

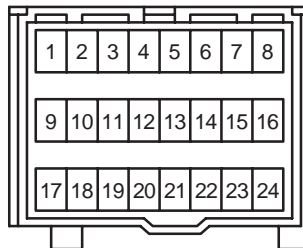

A 14
Orange

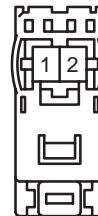

A 15
Black

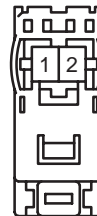

A 16
Yellow

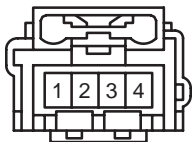

A 17



A 18
Yellow

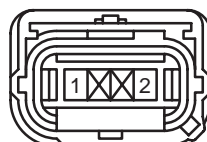

A 19
Yellow

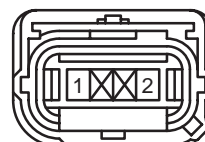

B 1
Gray



B 2
Gray



B 3



B 4
Black

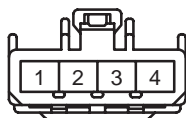

B 5

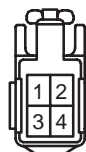

B 6

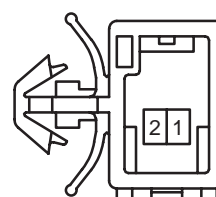

C 1
Black



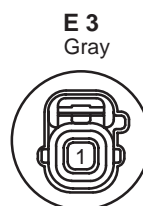
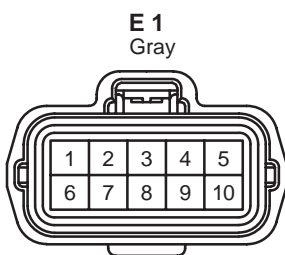
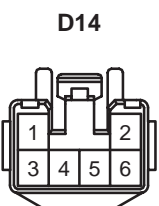
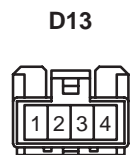
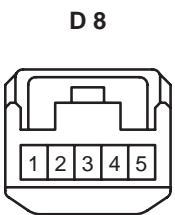
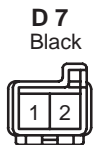
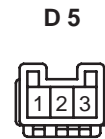
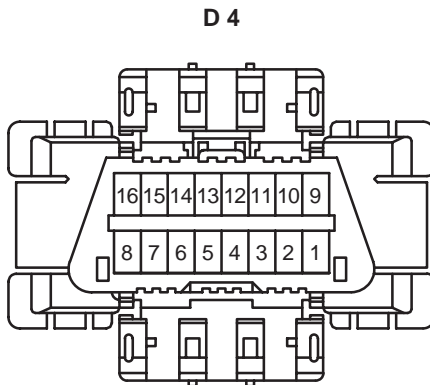
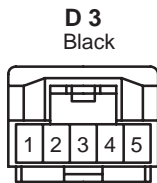
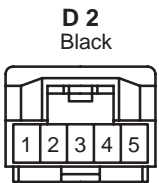
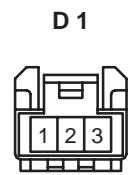
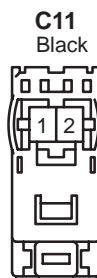
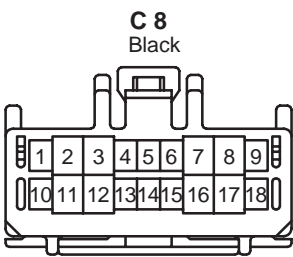
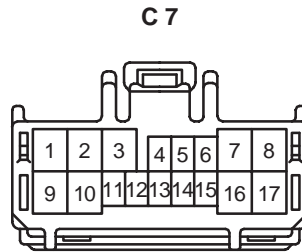
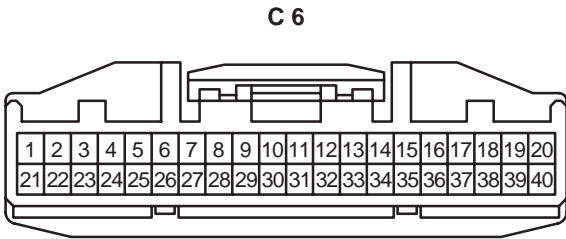

K CONNECTOR LIST

E 4

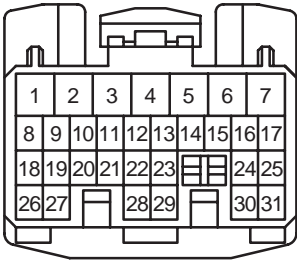

E 5

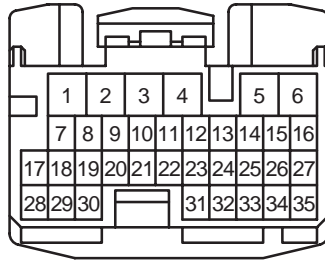

E 7

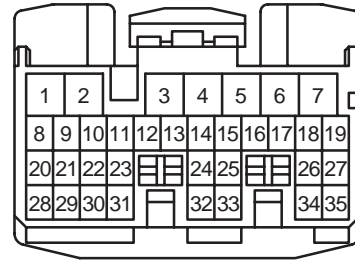

E 8

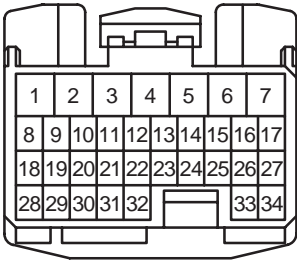

F 1
Brown

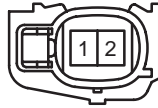

F 2
Brown

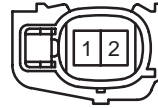

F 3
Brown

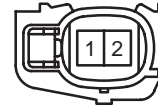

F 4
Brown

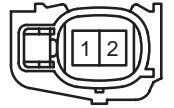

F 5



F 6



F 7



F 8

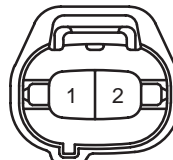

F 9
Gray



G 1
Black



G 2

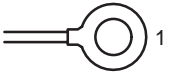

H 1
Black

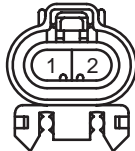

H 2
Brown



H 3
Black

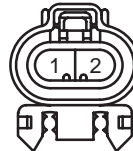

H 4
Brown



H 5
Dark Gray



H 6
Black



H 7
Black



I 1
Black



I 2
Black



I 3
Black

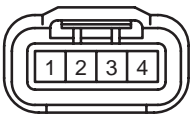

I 4
Black

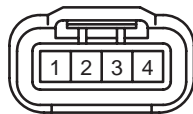

I 5

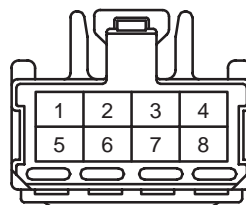

I6

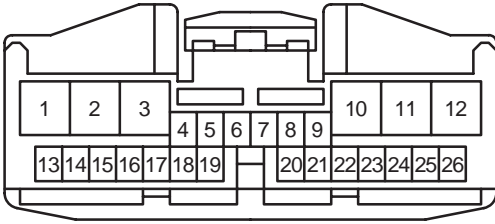

I7
Black



J1

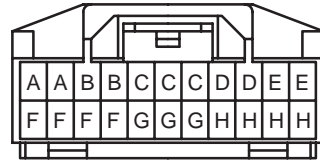

J2

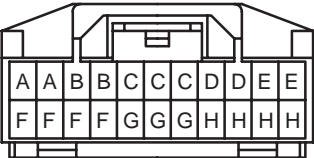

J3

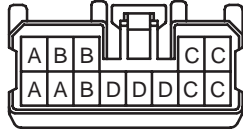

J4

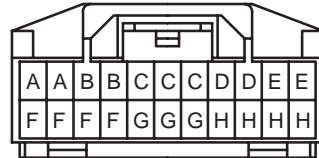

J5

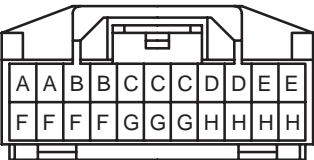

J6
Dark Gray

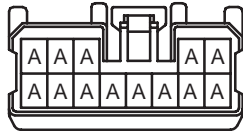

J7

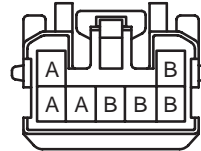

J8
Black

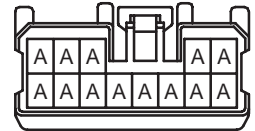

J9
Dark Gray

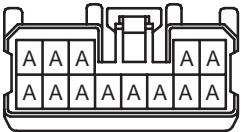

J10

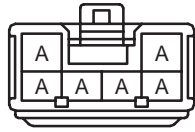

J11

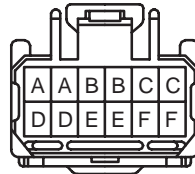

J12

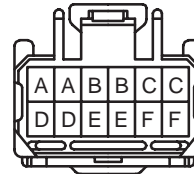

J13

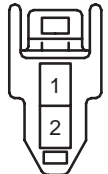

J14

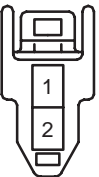

J15



K1
Black

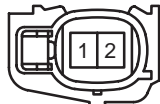

K2
Yellow

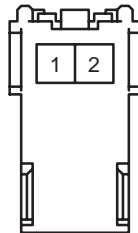

L1
Black

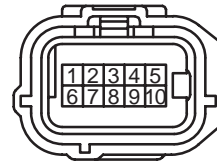

L2
Gray



L3
Gray



M1
Black



M2

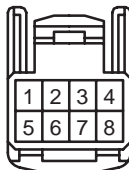

M3
Gray

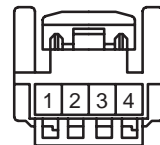

N1
Gray



N2

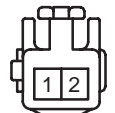

K CONNECTOR LIST

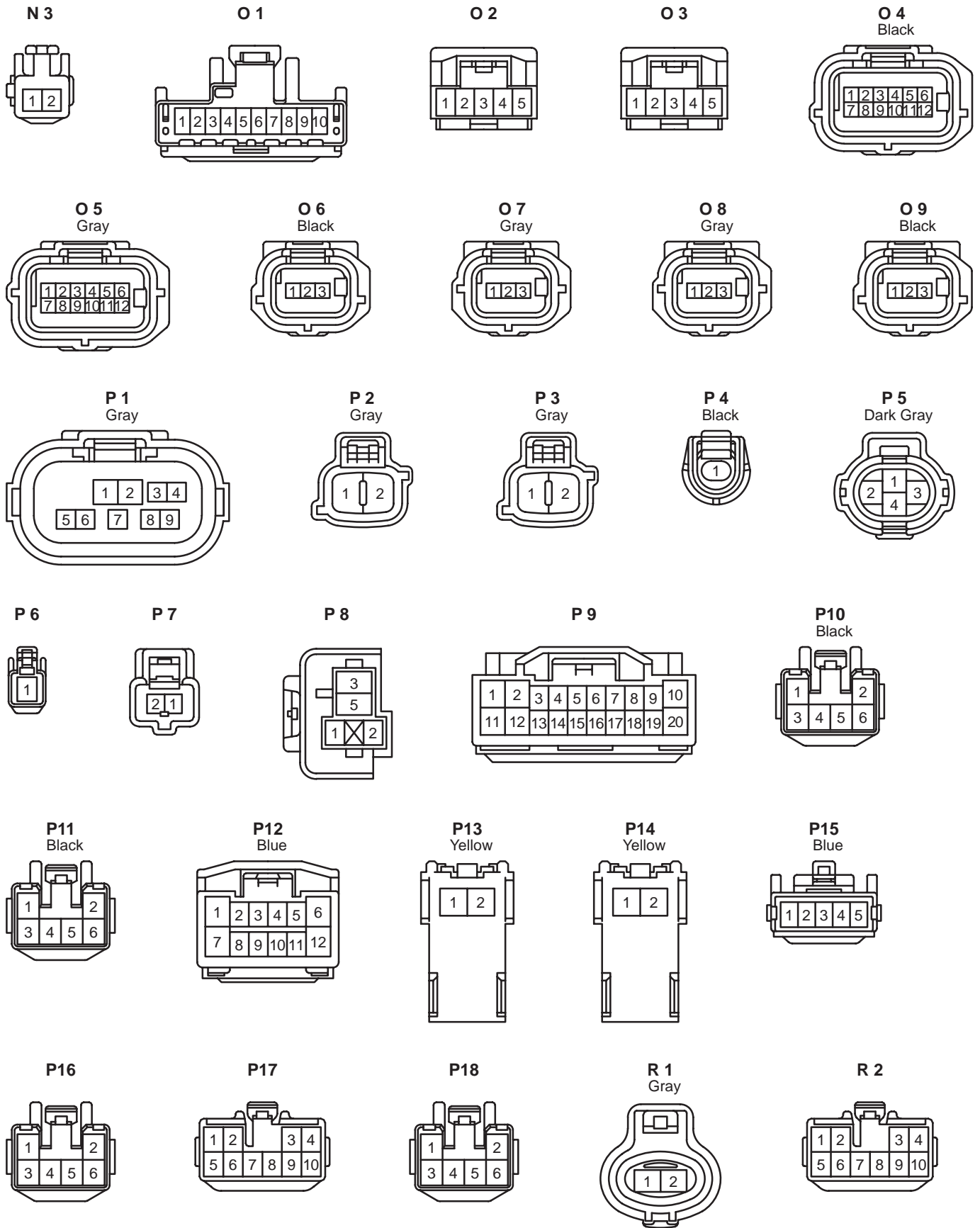

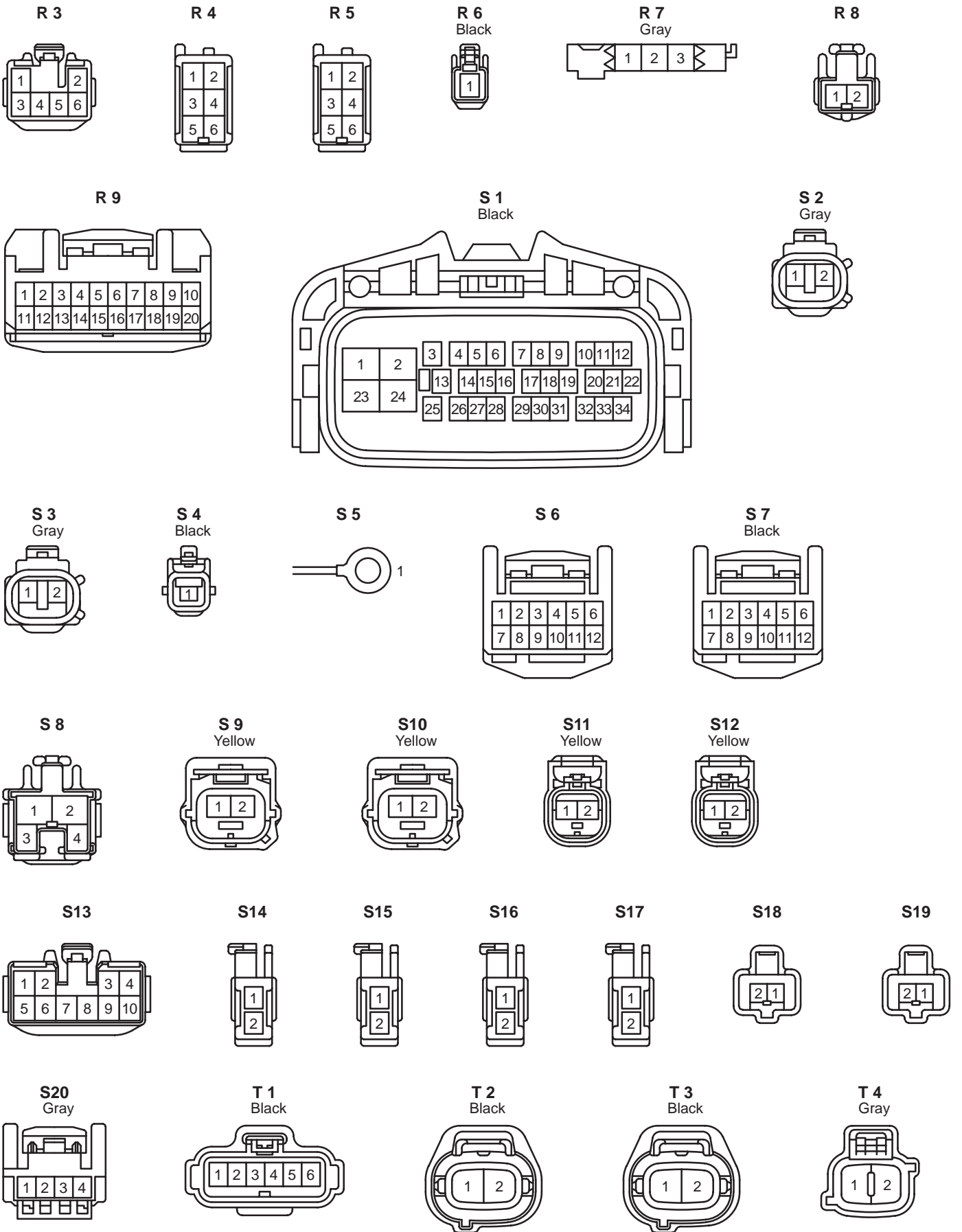

K CONNECTOR LIST

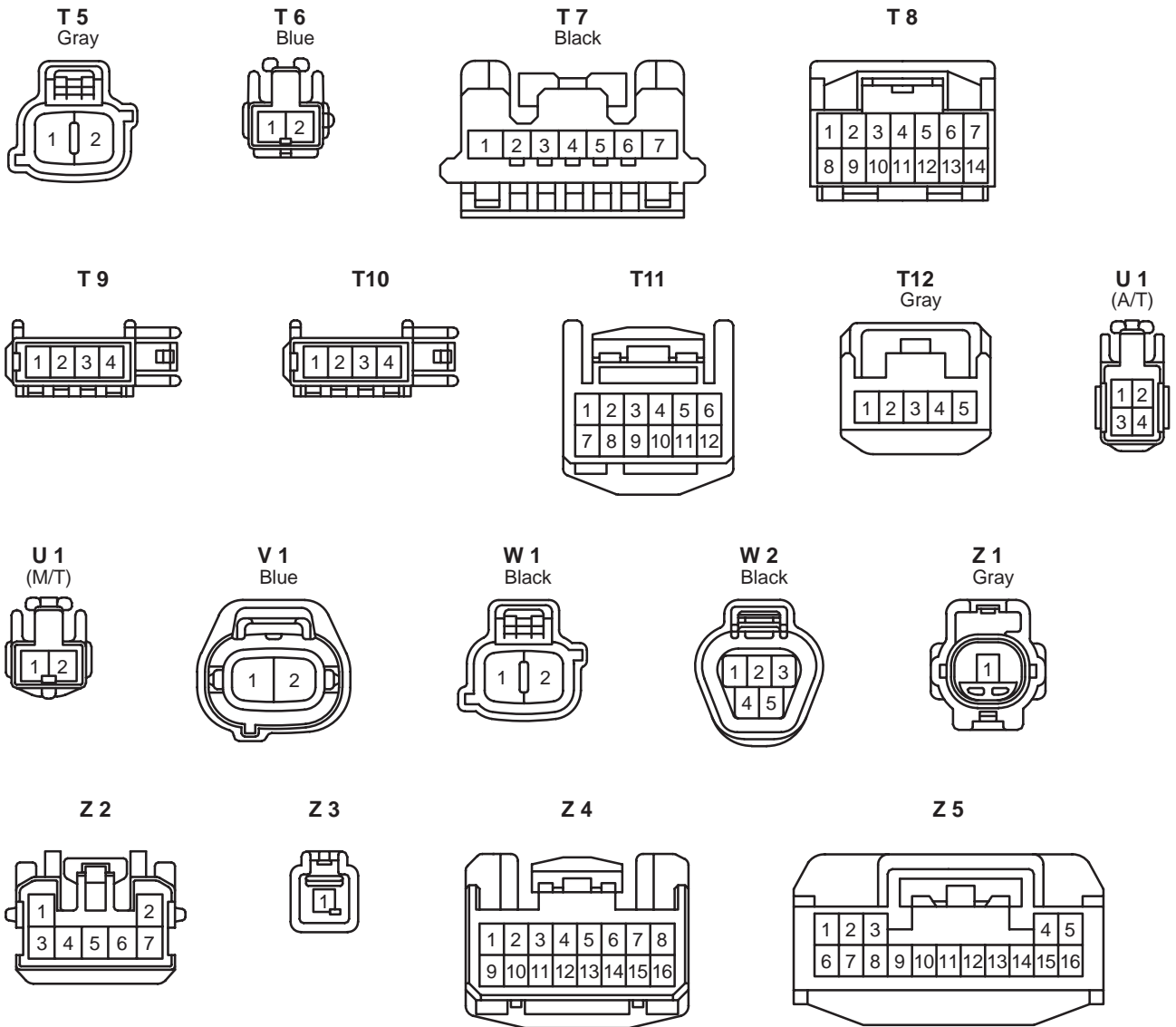

K CONNECTOR LIST

EA1

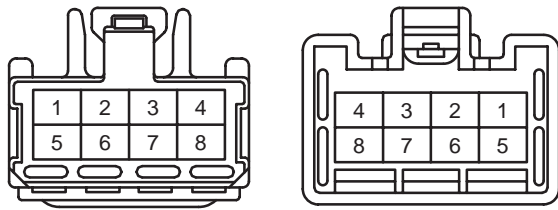

IA1

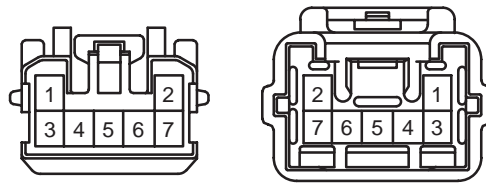

IB1 Gray

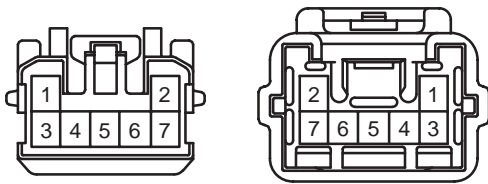

IB2

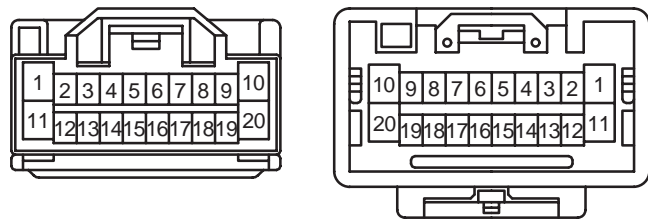

IC1 Gray

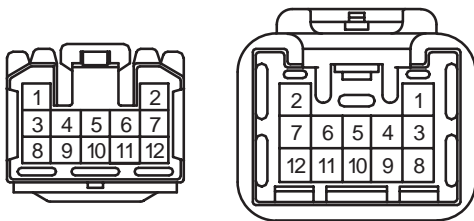

IC2 Blue

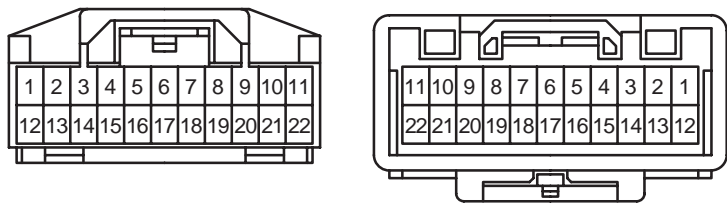

ID1 Yellow

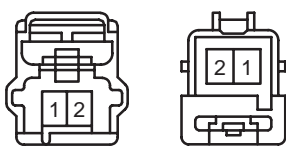

IE1 Black

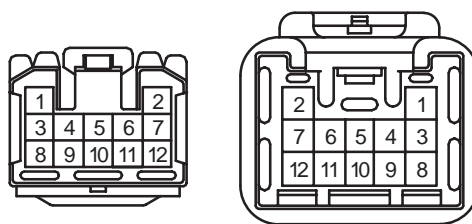

IE2

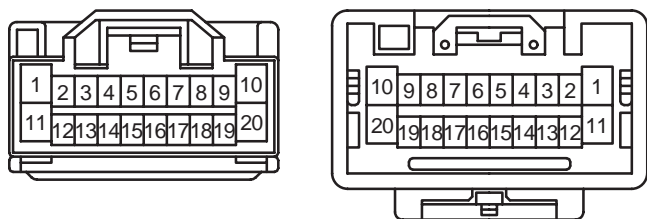

IE3 Yellow

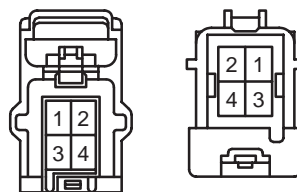

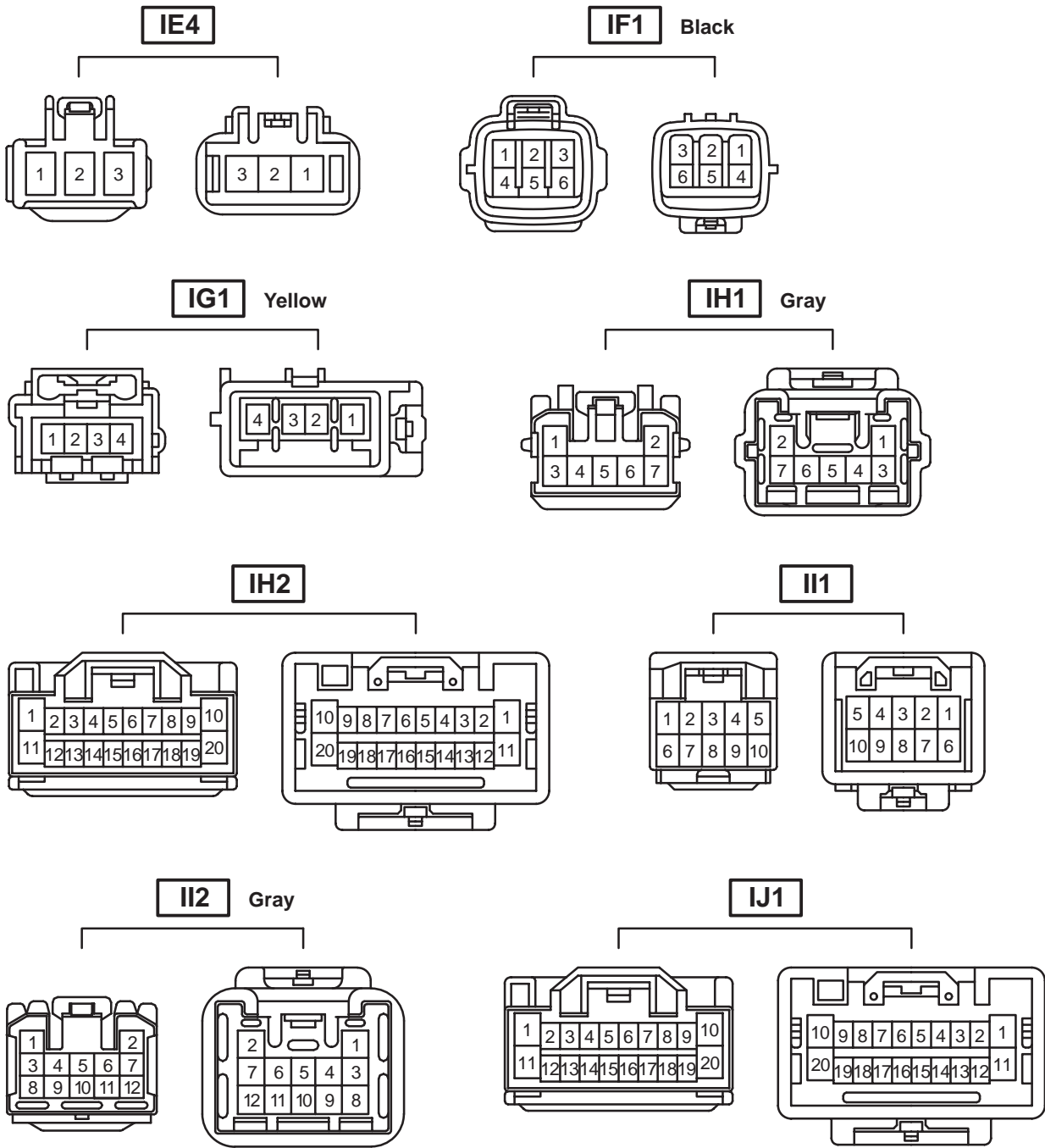

K CONNECTOR LIST

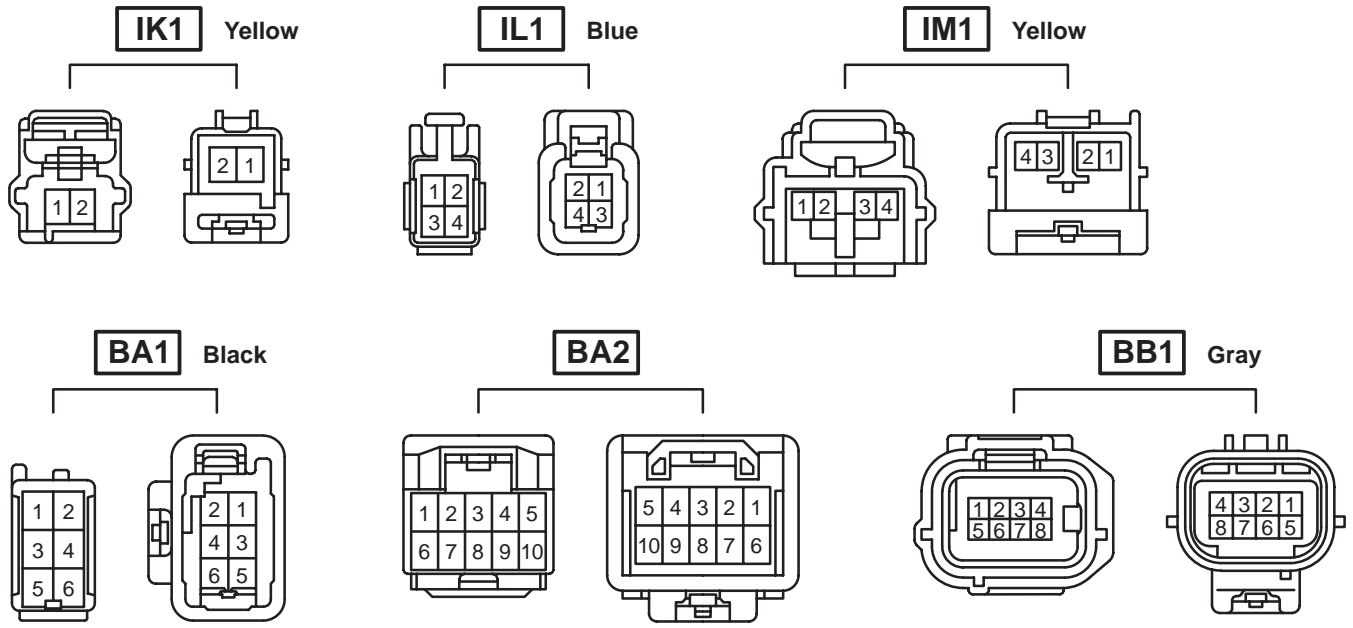

L PART NUMBER OF CONNECTORS

| Code | Part Name | Part Number | Code | Part Name | Part Number |
|------|--|-------------|------|---|-------------|
| A 1 | A/C Compressor | 90980-11271 | D 9 | Door Courtesy SW (Driver's Side) | 90980-12340 |
| A 2 | A/C Condenser Fan Motor | 90980-11410 | D10 | Door Courtesy SW (Front Passenger's Side) | |
| A 3 | Air Fuel Ratio Sensor (Bank 1 Sensor 1) | 90980-11178 | D11 | Door Lock Assembly (Driver's Side) | |
| A 4 | Airbag Sensor (Front LH) | 90980-11856 | D12 | Door Lock Assembly (Front Passenger's Side) | 90980-12226 |
| A 5 | Airbag Sensor (Front RH) | | | | |
| A 6 | Ambient Temp. Sensor | 90980-11070 | D13 | Door Lock Control SW | 90980-11950 |
| A 7 | A/C Control Assembly | 90980-12169 | D14 | Door Lock Control SW | 90980-12344 |
| A 8 | A/C Thermistor No.1 | 90980-11918 | E 1 | Electronically Controlled Transmission Solenoid | 90980-11658 |
| A 9 | A/T Shift Lever Illumination | 90980-12063 | E 2 | Engine Coolant Temp. Sensor | 90980-10735 |
| A10 | Accelerator Position Sensor | 90980-11144 | E 3 | Engine Oil Pressure SW | 90980-11363 |
| A11 | Airbag Sensor Assembly Center | 90980-12392 | E 4 | Engine Control Module | 90980-12142 |
| A12 | Airbag Sensor Assembly Center | 90980-12391 | E 5 | Engine Control Module | 90980-12146 |
| A13 | Airbag Sensor Assembly Center | 90980-12390 | E 7 | Engine Control Module | 90980-12145 |
| A14 | Airbag Squib (Front Passenger's Airbag Assembly) | 90980-12219 | E 8 | Engine Control Module | 90980-12144 |
| A15 | Airbag Squib (Front Passenger's Airbag Assembly) | | | | |
| A16 | Airbag Squib (Steering Wheel Pad) | 90980-12160 | F 1 | Fuel Injector (No.1) | 90980-11875 |
| A17 | Antenna Amplifier | 90980-10870 | F 2 | Fuel Injector (No.2) | |
| A18 | Airbag Sensor (Rear LH) | 90980-12241 | F 3 | Fuel Injector (No.3) | |
| A19 | Airbag Sensor (Rear RH) | | | | |
| B 1 | Back-Up Lamp SW | 90980-11250 | F 4 | Fuel Injector (No.4) | 90980-10355 |
| B 2 | Brake Fluid Level Warning SW | 90980-11207 | F 5 | Front Console Illumination | 90980-10942 |
| B 3 | Blower Motor | 90980-10214 | F 6 | Front Seat Inner Belt (Driver's Side) | 90980-11918 |
| B 4 | Blower Motor Control | 90980-11676 | F 7 | Front Seat Inner Belt (Driver's Side) | 90980-11156 |
| B 5 | Back Door Lock Assembly | 90980-12334 | F 8 | Front Seat Inner Belt (Front Passenger's Side) | 90980-11077 |
| B 6 | Back Door Opener SW | 90980-11967 | F 9 | Fuel Suction Pump and Gage Assembly | 90980-11964 |
| C 1 | Camshaft Position Sensor | 90980-10947 | G 1 | Generator | 90980-09213 |
| C 2 | Camshaft Timing Oil Control Valve | 90980-11162 | G 2 | Generator | 90980-11659 |
| C 3 | Crankshaft Position Sensor | 90980-10947 | H 1 | Headlamp (LH High) | 90980-11096 |
| C 4 | Cigarette Lighter | 90980-10760 | H 2 | Headlamp (LH Low) | 90980-11659 |
| C 5 | Clutch Start SW | 90980-12341 | H 3 | Headlamp (RH High) | 90980-11096 |
| C 6 | Combination Meter | 90980-12169 | H 4 | Headlamp (RH Low) | 90980-11930 |
| C 7 | Combination SW | 90980-11672 | H 5 | Heated Oxygen Sensor (Bank 1 Sensor 2) | 90980-10619 |
| C 8 | Combination SW | 90980-11594 | H 6 | Horn (Low) | |
| C 9 | Cruise Control Clutch SW | 90980-12341 | H 7 | Horn (High) | 90980-11885 |
| C10 | Center Stop Lamp | 90980-11918 | I 1 | Ignition Coil (No.1) | |
| C11 | Curtain Shield Airbag Squib (LH) | 90980-12219 | I 2 | Ignition Coil (No.2) | |
| C12 | Curtain Shield Airbag Squib (RH) | | | | |
| D 1 | Damper Servo Motor (Air Inlet) | 90980-11987 | I 3 | Ignition Coil (No.3) | 90980-11615 |
| D 2 | Damper Servo Motor (Air Mix) | 90980-11909 | I 4 | Ignition Coil (No.4) | 90980-12203 |
| D 3 | Damper Servo Motor (Air Vent Mode) | | | | |
| D 4 | Data Link Connector 3 | 90980-11978 | I 5 | Ignition SW | 90980-11148 |
| D 5 | Diode (Fan) | 90980-11251 | I 6 | Integration Relay | 90980-11915 |
| D 7 | Diode (Room Lamp) | 90980-10962 | I 7 | Ignition Cylinder Lamp | |
| D 8 | Door Control Receiver | 90980-12366 | J 1 | Junction Connector | |
| | | | J 2 | Junction Connector | 90980-12346 |
| | | | J 3 | Junction Connector | |

Note: Not all of the above part numbers of the connector are established for the supply.

| Code | Part Name | Part Number | Code | Part Name | Part Number |
|------|--|-------------|------|---|-------------|
| J 4 | Junction Connector | 90980-11915 | P13 | Pretensioner (LH) | 90980-12253 |
| J 5 | Junction Connector | | P14 | Pretensioner (RH) | |
| J 6 | Junction Connector | 90980-12346 | P15 | Power Window SW (Front Passenger's Side) | 90980-10789 |
| J 7 | Junction Connector | 90980-12336 | P16 | Power Window Regulator Motor (Front RH) | 90980-12344 |
| J 8 | Junction Connector | 90980-12346 | P17 | Power Window Master SW | 90980-12540 |
| J 9 | Junction Connector | | | | |
| J10 | Junction Connector | 90980-10976 | P18 | Power Window Regulator Motor (Front LH) | 90980-12344 |
| J11 | Junction Connector | 90980-11661 | R 1 | Radiator Fan Motor | 90980-10928 |
| J12 | Junction Connector | | | | |
| J13 | Junction Connector | 90980-12355 | R 2 | Radio Receiver Assembly | 90980-12540 |
| J14 | Junction Connector | | | | |
| J15 | Junction Connector | 90980-12340 | R 3 | Radio Receiver Assembly | 90980-12539 |
| K 1 | Knock Control Sensor (Bank 1) | 90980-11875 | R 4 | Rear Combination Lamp (LH) | 90980-11011 |
| K 2 | Knee Airbag Squib | 90980-12253 | R 5 | Rear Combination Lamp (RH) | |
| L 1 | Canister Pump Module | 90980-12380 | R 6 | Rear Window Defogger | 90980-12340 |
| L 2 | License Plate Lamp (LH) | 90980-11148 | R 7 | Room Lamp (Center) | 81366-68010 |
| L 3 | License Plate Lamp (RH) | | | | |
| M 1 | Mass Air Flow Meter | 90980-12292 | R 8 | Room Lamp (Left Quarter) | 90980-12342 |
| M 2 | Map Lamp | 90980-12221 | R 9 | Radio Receiver Assembly | 90980-12259 |
| M 3 | Map Lamp | 82824-21030 | S 1 | Skid Control ECU with Actuator | 90980-12020 |
| N 1 | Noise Filter (Ignition) | 90980-10843 | S 2 | Speed Sensor (Front LH) | 90980-11003 |
| N 2 | Noise Filter (DOME) | 90980-12341 | S 3 | Speed Sensor (Front RH) | |
| N 3 | Noise Filter (DEF and Stop) | | | | |
| O 1 | Outer Mirror SW | 90980-11657 | S 4 | Starter | 90980-11400 |
| O 2 | Outer Rear View Mirror (LH) | 90980-11909 | S 5 | Starter | 90980-09506 |
| O 3 | Outer Rear View Mirror (RH) | | | | |
| O 4 | Occupant Classification ECU | 90980-12356 | S 6 | Shift Lock Control ECU | 90980-12183 |
| O 5 | Occupant Classification ECU | 90980-12357 | S 7 | Spiral Cable | |
| O 6 | Occupant Classification Sensor Front LH | 90980-12353 | S 8 | Stop Lamp SW | 90980-11118 |
| O 7 | Occupant Classification Sensor Rear LH | 90980-12354 | S 9 | Side Airbag Sensor (LH) | 90980-11856 |
| O 8 | Occupant Classification Sensor Front RH | | | | |
| O 9 | Occupant Classification Sensor Rear RH | 90980-12353 | S10 | Side Airbag Sensor (RH) | 90980-12343 |
| P 1 | Park/Neutral Position SW | 90980-12362 | S11 | Side Airbag Squib (LH) | |
| P 2 | Parking Lamp (LH) | 90980-11019 | S12 | Side Airbag Squib (RH) | |
| P 3 | Parking Lamp (RH) | | | | |
| P 4 | Power Steering Oil Pressure SW | 90980-11428 | S13 | Sliding Roof Control ECU | 90980-10801 |
| P 5 | Pressure SW | 90980-10943 | S14 | Speaker (Front Door LH) | 90980-12343 |
| P 6 | Parking Brake SW | 90980-12340 | S15 | Speaker (Front Door RH) | |
| P 7 | Power Point Socket | 90980-10859 | S16 | Speaker (Rear LH) | |
| P 8 | Power Point Socket Relay | 82660-20340 | S17 | Speaker (Rear RH) | |
| P 9 | Power Window Master SW | 90980-12166 | S18 | Speed Sensor (Rear LH) | 90980-11060 |
| P10 | Power Window Regulator Motor (Front LH) | 90980-12344 | S19 | Speed Sensor (Rear RH) | |
| P11 | Power Window Regulator Motor (Front RH) | | | | |
| P12 | Power Window SW (Front Passenger's Side) | 90980-11947 | S20 | Stereo Jack Adapter | 82824-21030 |
| | | | T 1 | Throttle Body Assembly | 90980-11858 |
| | | | T 2 | Transmission Revolution Sensor (Counter Gear) | 90980-12634 |
| | | | T 3 | Transmission Revolution Sensor (Turbine) | |
| | | | T 4 | Turn Signal Lamp (Front LH) | 90980-11019 |
| | | | T 5 | Turn Signal Lamp (Front RH) | |
| | | | T 6 | Tire Pressure Warning Reset SW | 90980-10906 |
| | | | T 7 | Transponder Key Amplifier | 90980-12092 |
| | | | T 8 | Transponder Key ECU | 90980-11911 |

L PART NUMBER OF CONNECTORS

| Code | Part Name | Part Number | Code | Part Name | Part Number |
|------|--|-------------|------|--|-------------|
| T 9 | Tweeter (LH) | 90980-12304 | W 1 | Windshield Washer Motor | 90980-11019 |
| T10 | Tweeter (RH) | | W 2 | Windshield Wiper Motor | 90980-11599 |
| T11 | Tire Pressure Warning ECU | 90980-12183 | Z 1 | Option Connector (Front Fog Lamp) | 90980-11007 |
| T12 | Tire Pressure Warning Antenna and Receiver | 90980-12366 | Z 2 | Option Connector (Front Fog Lamp SW) | 90980-12336 |
| U 1 | Unlock Warning SW (A/T) | 90980-12334 | Z 3 | Option Connector (TVIP) | 90980-10870 |
| | Unlock Warning SW (M/T) | 90980-12342 | Z 4 | Option Connector (IPOD Unit) | 90980-12155 |
| V 1 | VSV (Purge) | 90980-12634 | Z 5 | Option Connector (Radio Receiver Assembly) | 90980-12423 |

Note: Not all of the above part numbers of the connector are established for the supply.

* The system shown here is an EXAMPLE ONLY. It is different to the actual circuit shown in the wiring diagram section.

M OVERALL ELECTRICAL WIRING DIAGRAM

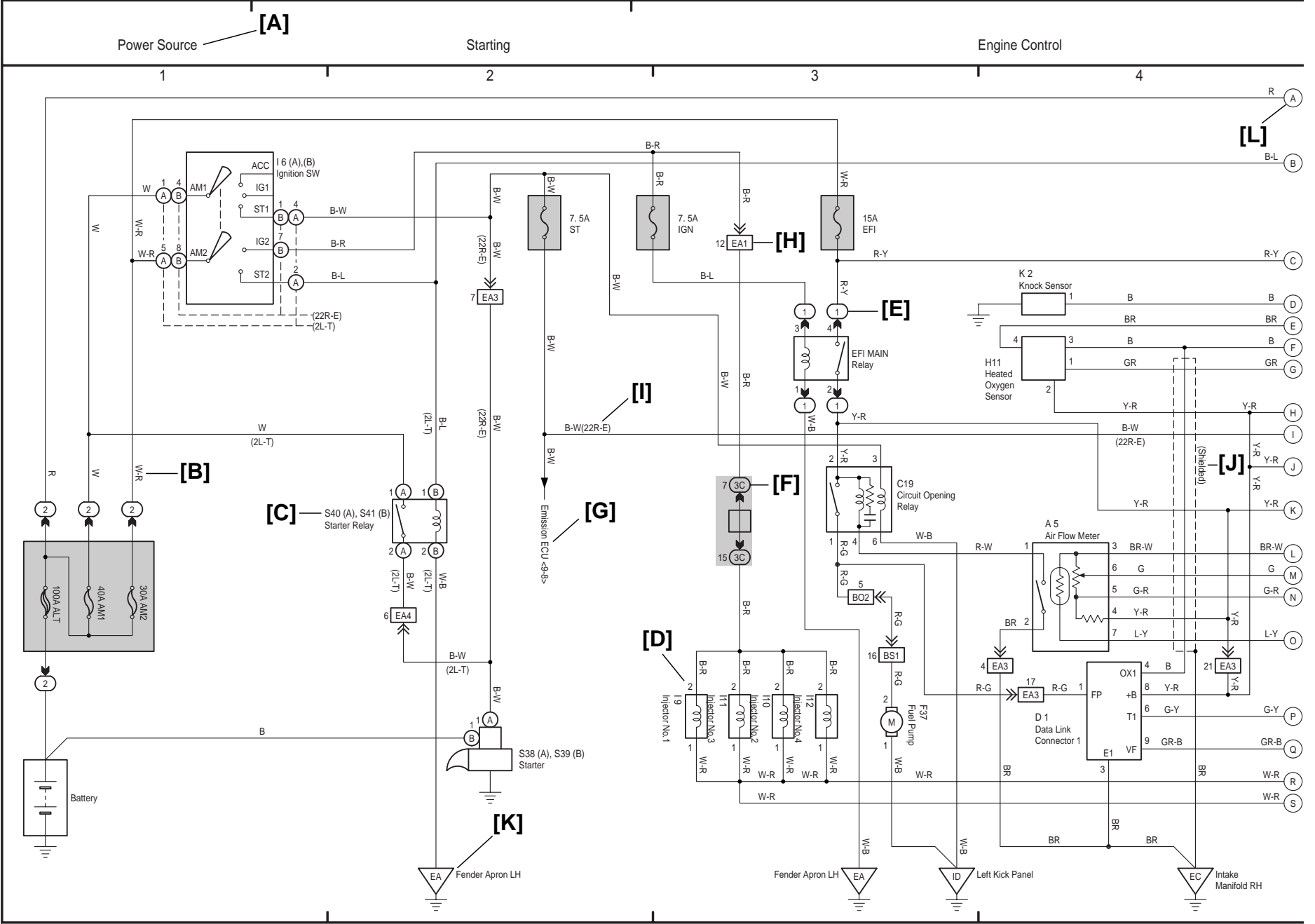

HOW TO READ THIS SECTION

[A] : System Title

[B] : Indicates the wiring color.

Wire colors are indicated by an alphabetical code.

- | | | |
|------------|------------|------------------|
| B = Black | W = White | BR = Brown |
| L = Blue | V = Violet | SB = Sky Blue |
| R = Red | G = Green | LG = Light Green |
| P = Pink | Y = Yellow | GR = Gray |
| O = Orange | | |

The first letter indicates the basic wire color and the second letter indicates the color of the stripe.

Example: L – Y

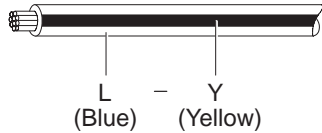

[C] : The position of the parts is the same as shown in the wiring diagram and wire routing.

[D] : Indicates the pin number of the connector. The numbering system is different for female and male connectors.

Example : Numbered in order from upper left to lower right

Numbered in order from upper right to lower left

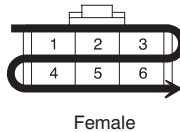

Female

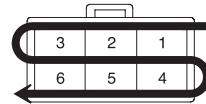

Male

The numbering system for the overall wiring diagram is the same as above

[E] : Indicates a Relay Block. No shading is used and only the Relay Block No. is shown to distinguish it from the J/B.

Example : Indicates Relay Block No.1

[F] : Junction Block (The number in the circle is the J/B No. and the connector code is shown beside it). Junction Blocks are shaded to clearly separate them from other parts.

Example:

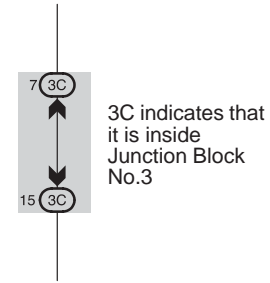

[G] : Indicates related system.

[H] : Indicates the wiring harness and wiring harness connector. The wiring harness with male terminal is shown with arrows (↘). Outside numerals are pin numbers.

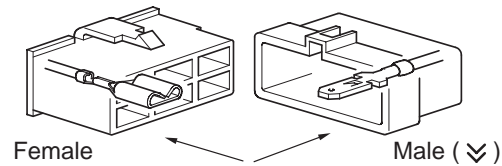

[I] : () is used to indicate different wiring and connector, etc. when the vehicle model, engine type, or specification is different.

[J] : Indicates a shielded cable.



[K] : Indicates and located on ground point.

[L] : The same code occurring on the next page indicates that the wire harness is continuous.

SYSTEM INDEX

| SYSTEMS | LOCATION | SYSTEMS | LOCATION |
|--|----------|--|----------|
| ABS | 16-2 | Multiplex Communication System (CAN) | 3-15 |
| Air Conditioning | 25-2 | Option Connector (Front Fog Light) | 6-4 |
| Audio System | 22-3 | Option Connector (TVIP) | 15-7 |
| Back Door Opener | 15-6 | Power Outlet | 22-2 |
| Back-Up Light | 11-3 | Power Source | 1-25-1 |
| Charging | 2-3 | Power Window (w/ Jam Protection) | 13-2 |
| Cigarette Lighter | 21-4 | Power Window (w/o Jam Protection) | 14-2 |
| Combination Meter | 23-2 | Radiator Fan and Condenser Fan | 24-3 |
| Cruise Control | 5-2 | Rear Window Defogger | 21-2 |
| Door Lock Control | 15-2 | Remote Control Mirror | 21-3 |
| Electronically Controlled Transmission and A/T Indicator | 4-2 | Seat Belt Warning | 19-2 |
| Engine Control | 3-5 | Shift Lock | 20-2 |
| Engine Immobiliser System | 3-2 | Sliding Roof | 20-4 |
| Front Wiper and Washer | 12-2 | SRS | 18-2 |
| Headlight | 6-2 | Starting | 1-2 |
| Horn | 2-4 | Stop Light | 11-4 |
| Ignition | 1-3 | Taillight | 8-2 |
| Illumination | 9-2 | Tire Pressure Warning System | 17-3 |
| Interior Light | 10-2 | Turn Signal and Hazard Warning Light | 7-2 |
| Key Reminder | 19-4 | Wireless Door Lock Control | 15-8 |
| Light Reminder | 19-4 | | |

Power Source

Starting

Ignition

1 2 3 4

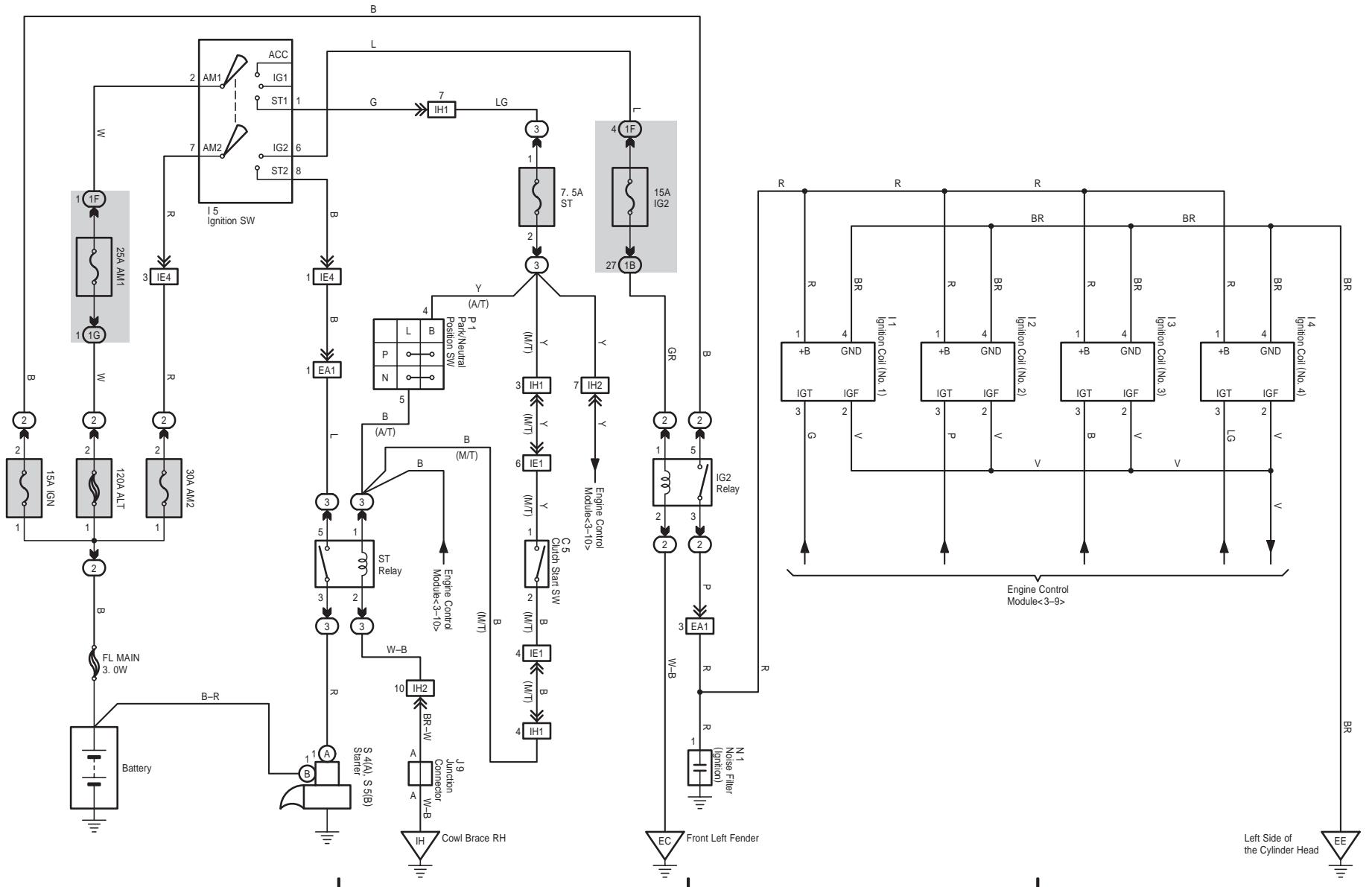

Left Side of the Cylinder Head



M OVERALL ELECTRICAL WIRING DIAGRAM

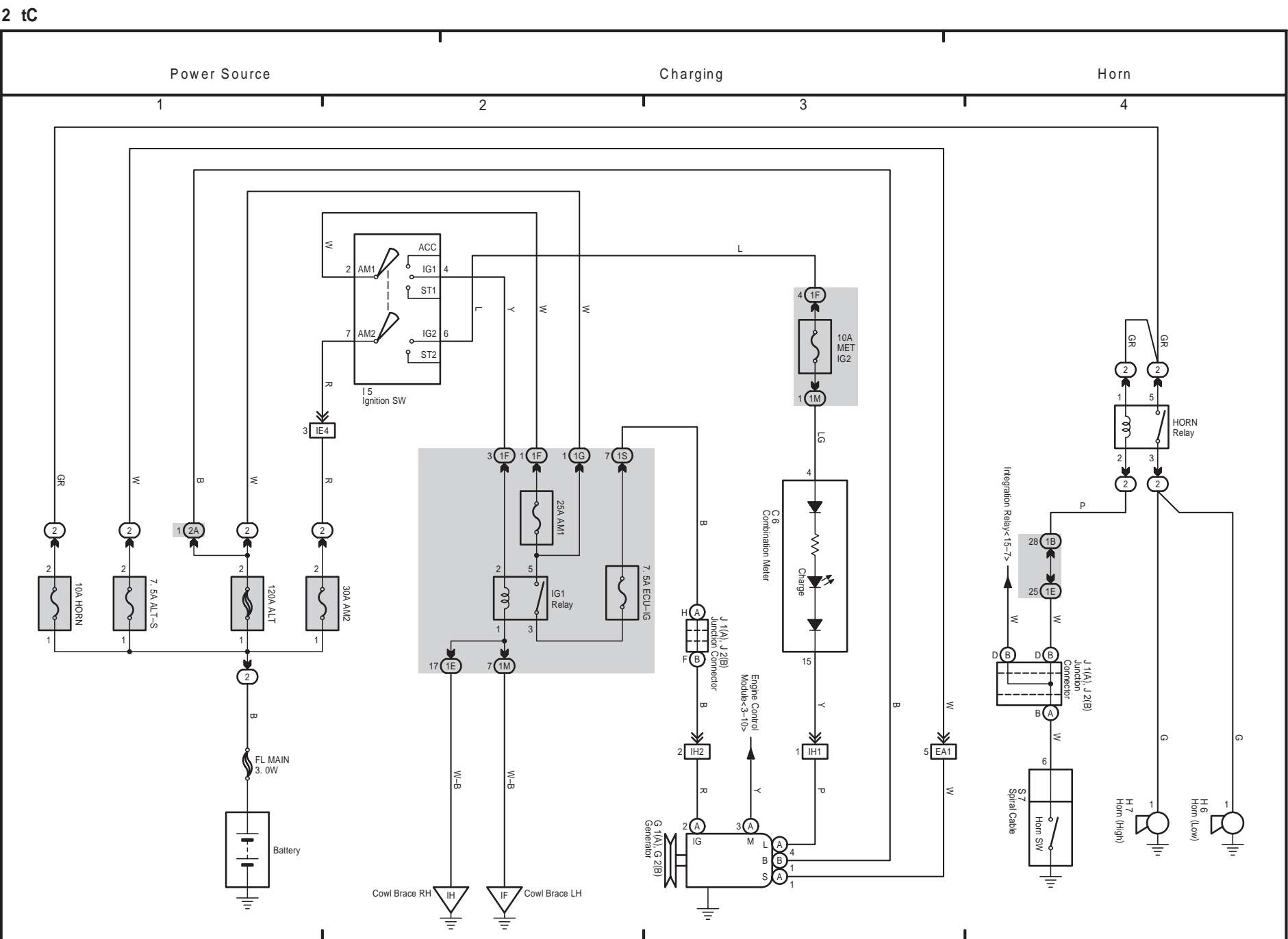

2 tC

214

SCION tC (EM0300U)

(Cont. next page)

3 tC

216

SCION tC (EM0300U)

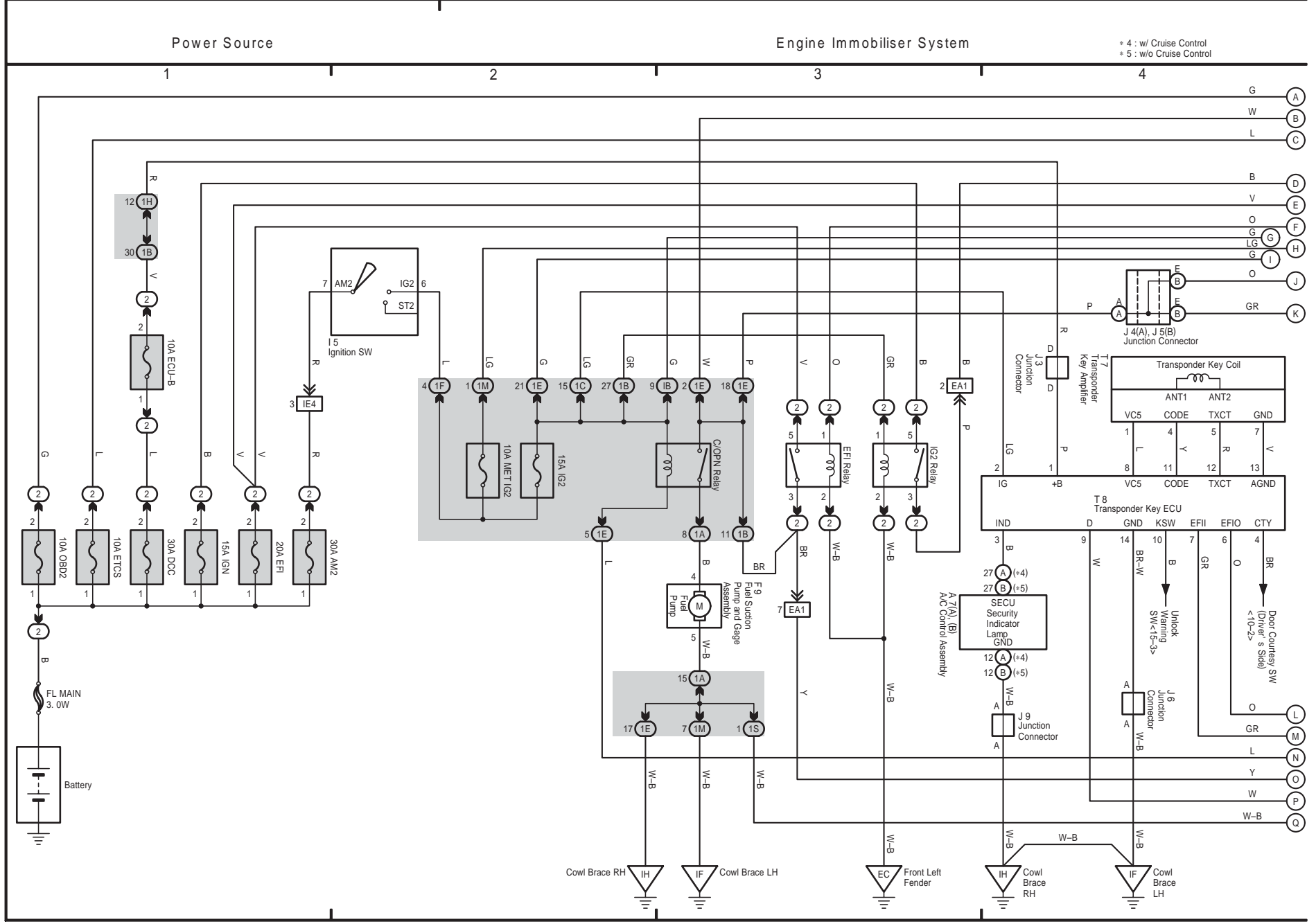

Engine Control

- * 1 : Malfunction Indicator Lamp
- * 2 : Shielded
- * 3 : w/ Engine Immobiliser System

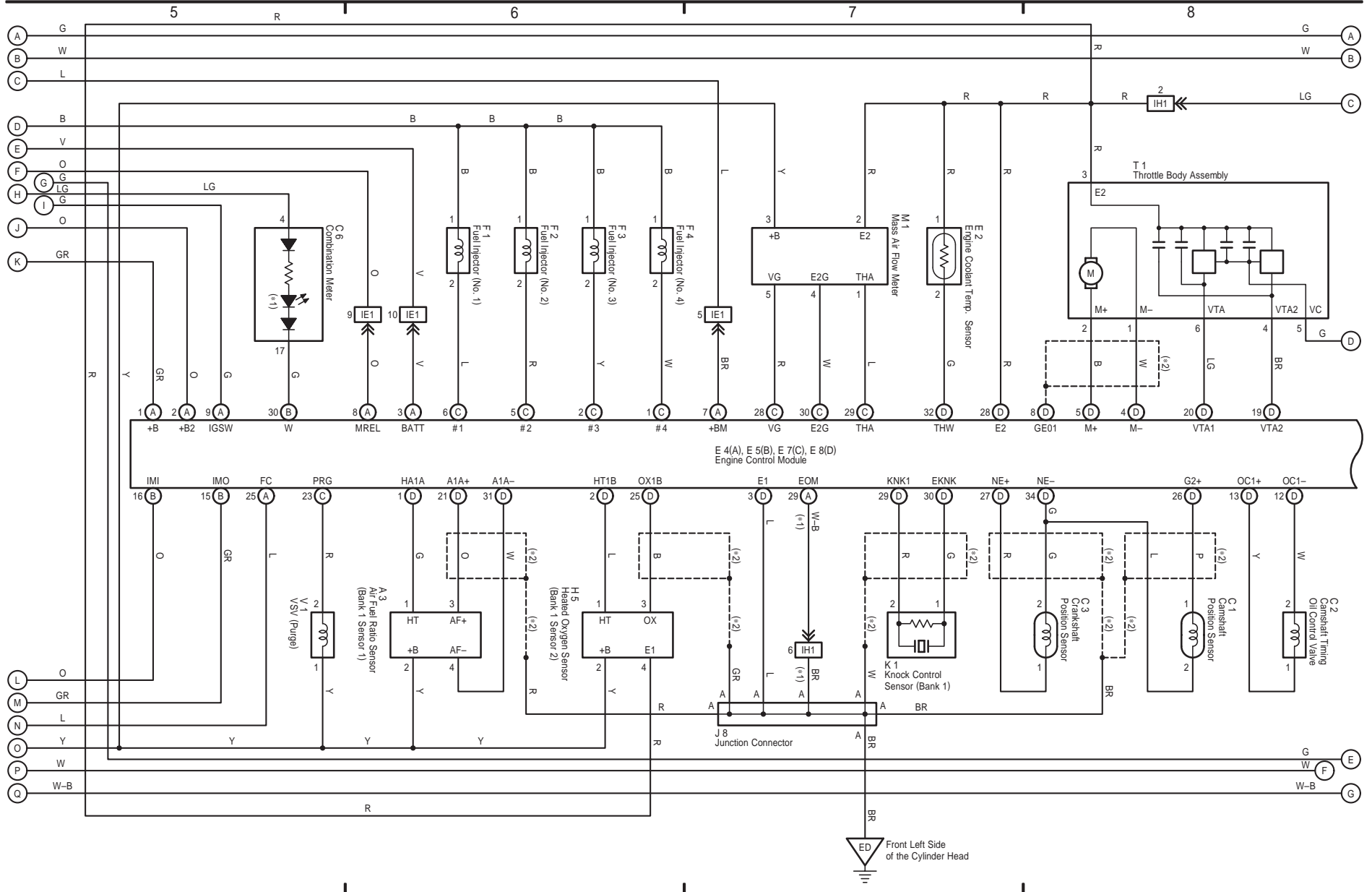

SCION tC (EM0300U)



Engine Control

Multiplex Communication System (CAN)

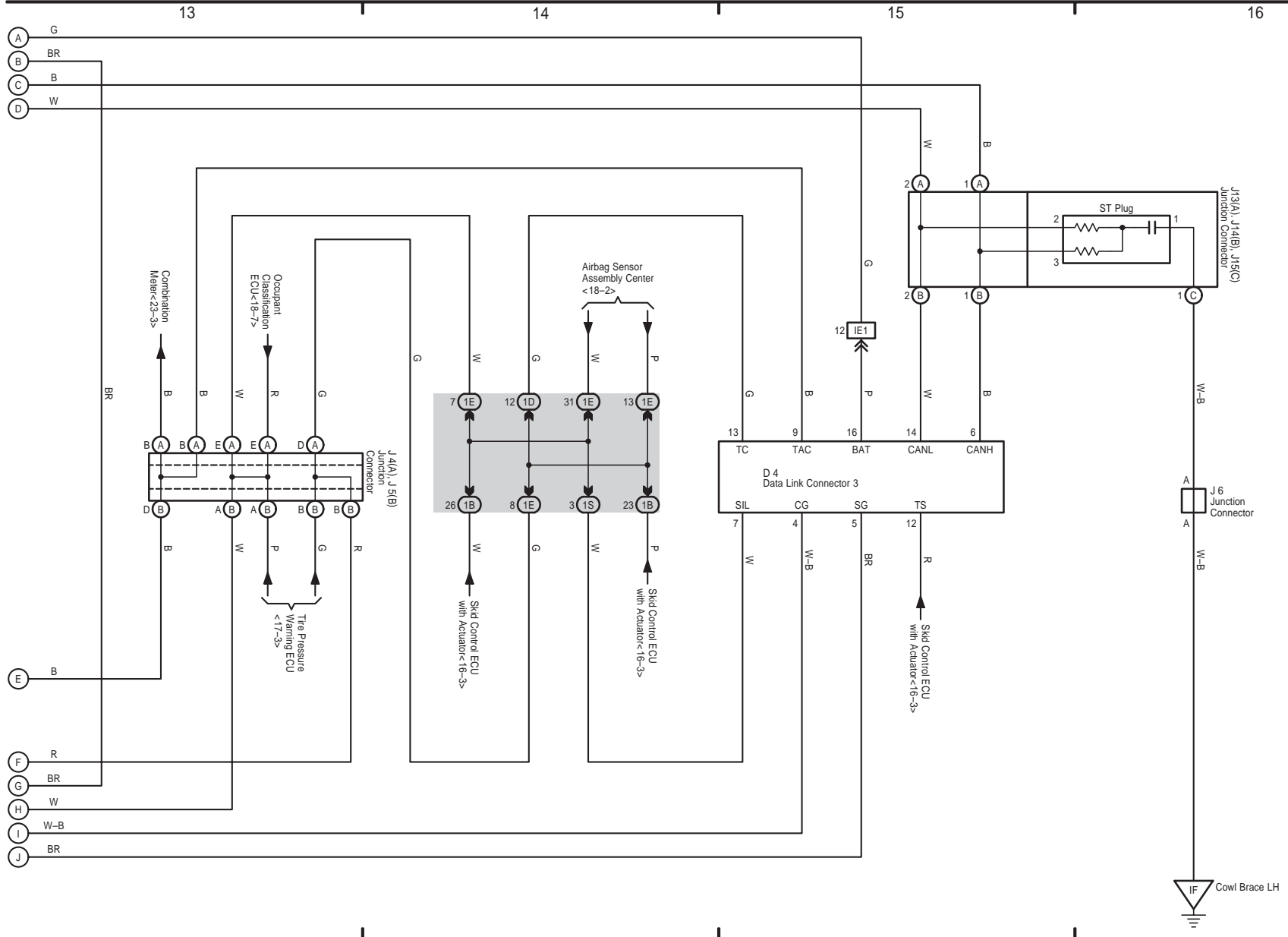

SCION tC (EM0300U)



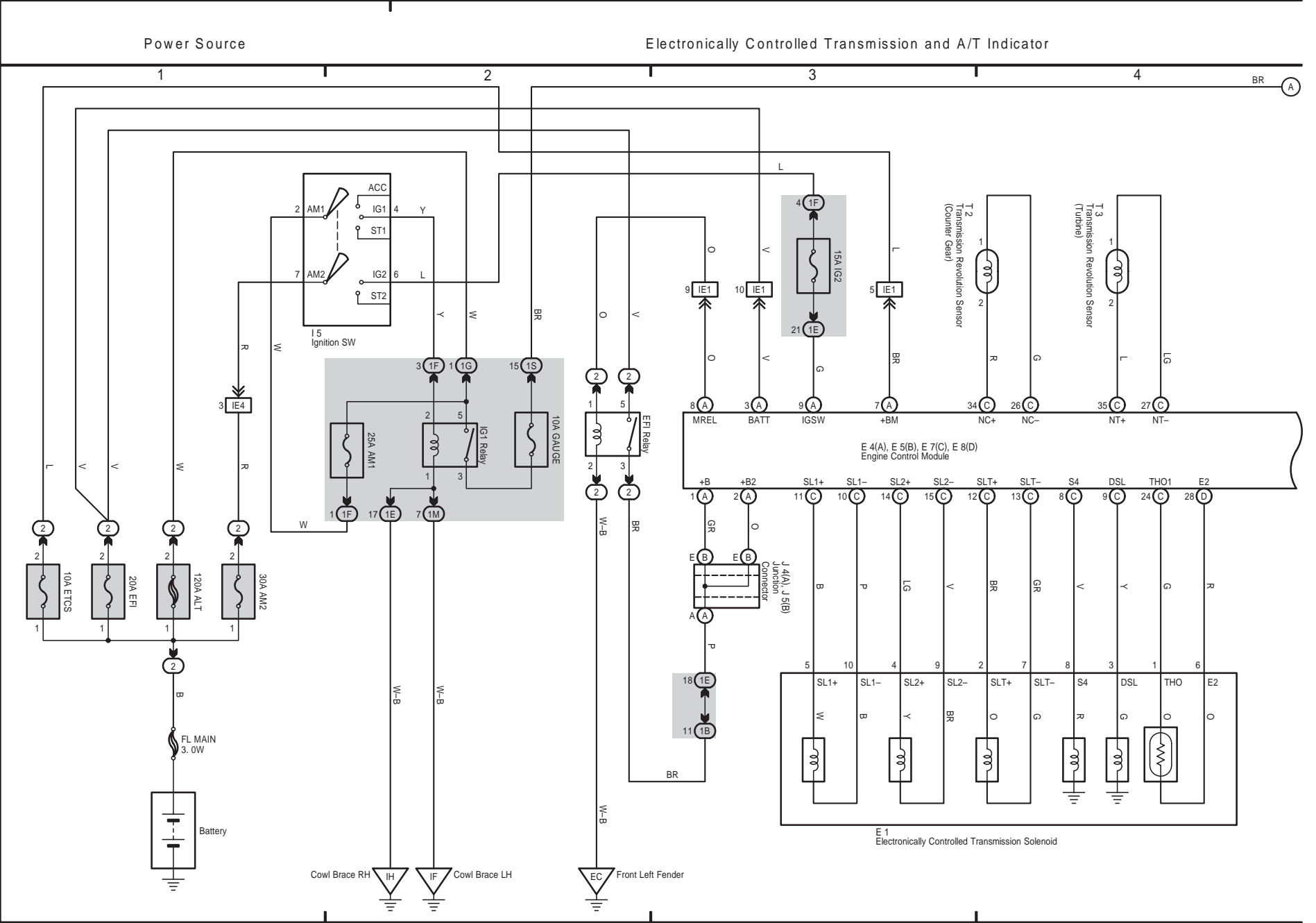

OVERALL ELECTRICAL WIRING DIAGRAM

Electronically Controlled Transmission and A/T Indicator



* 1 : w/ Engine Immobiliser System

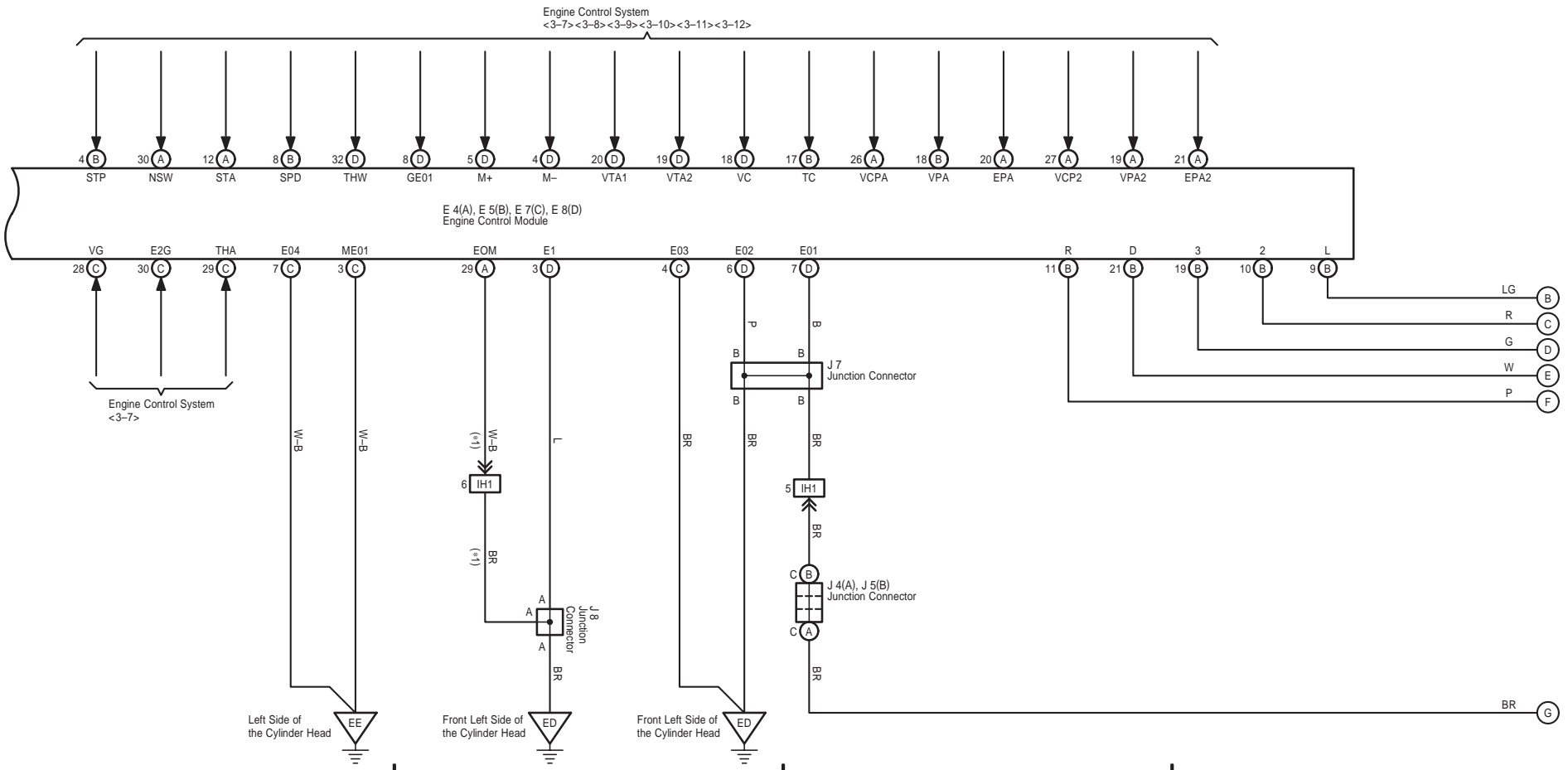

SCION tC (EM0300U)



Electronically Controlled Transmission and A/T Indicator

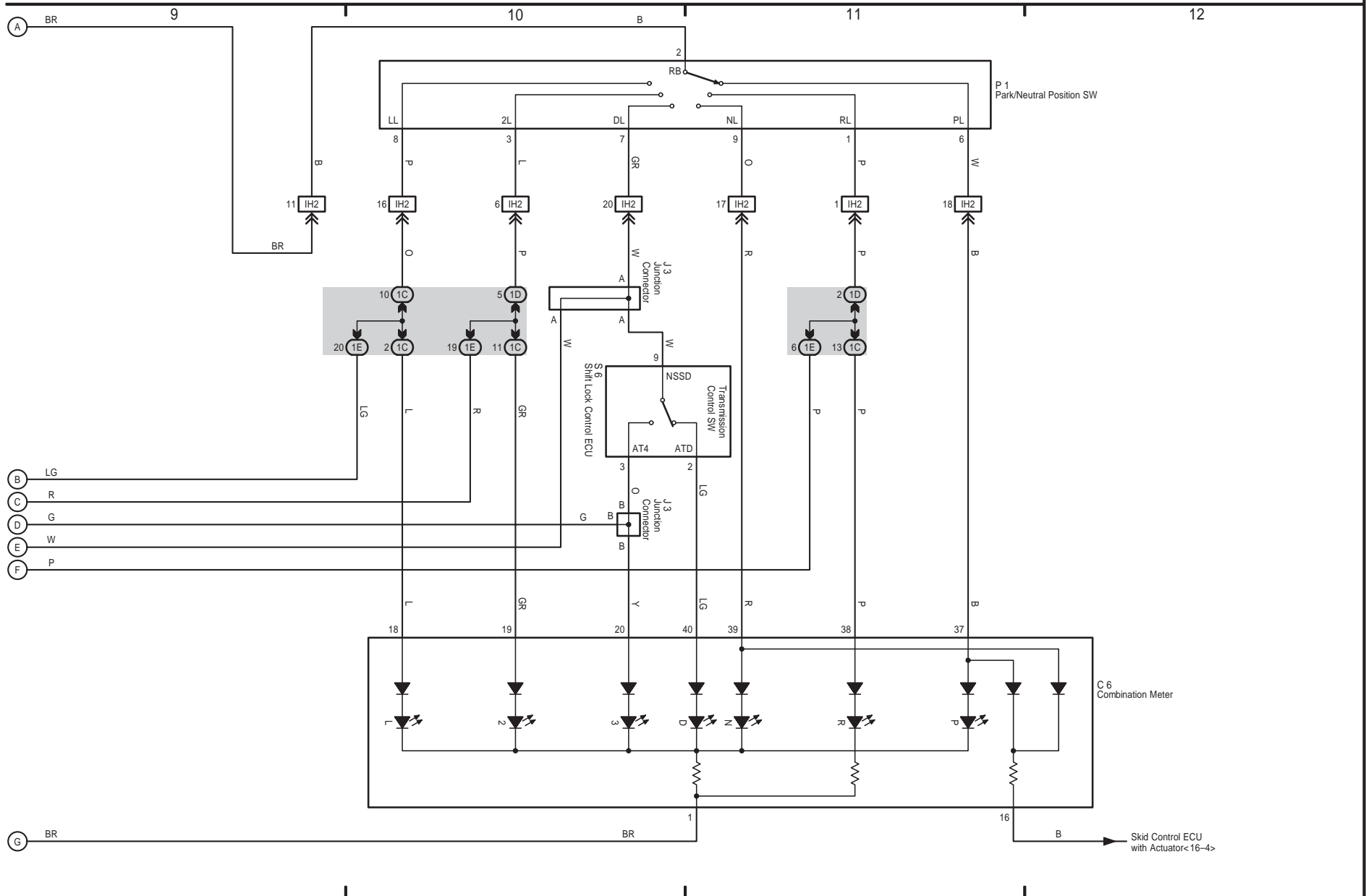

Cruise Control

5

6

7

8

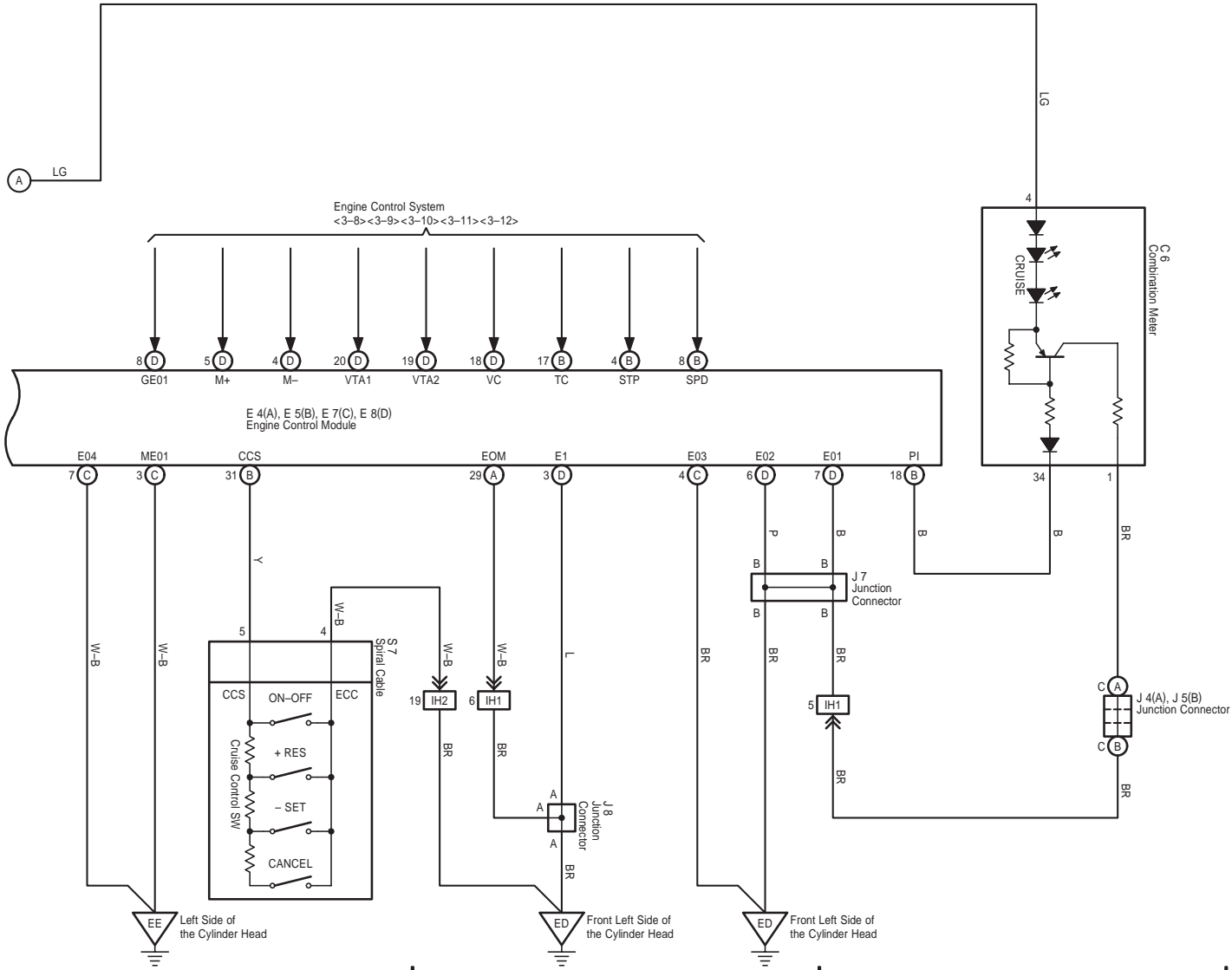

SCION tC (EM0300U)

M OVERALL ELECTRICAL WIRING DIAGRAM

6 tC

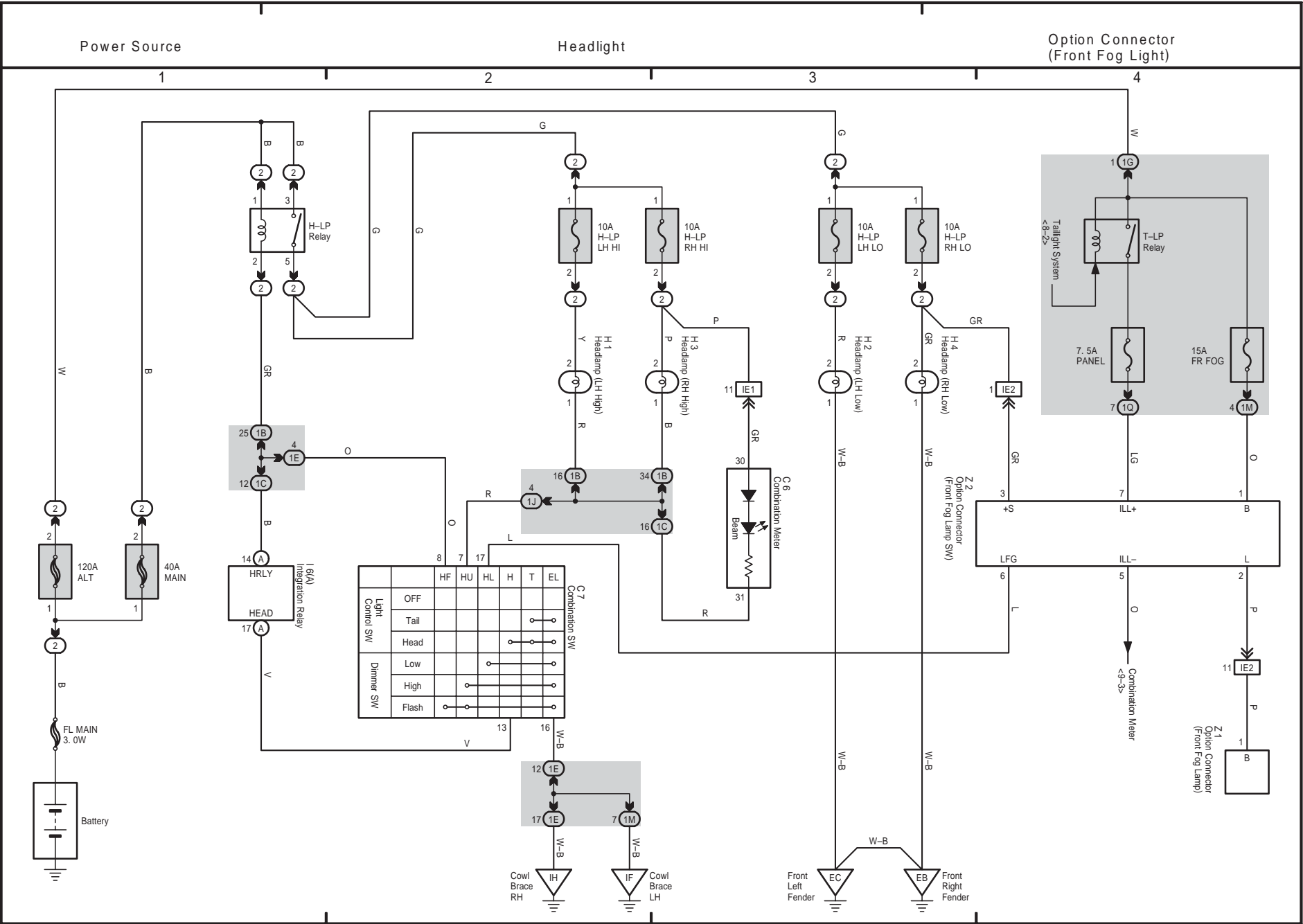

SCION tC (EM0300U)

226

Power Source

Turn Signal and Hazard Warning Light

* 1 : w/ Cruise Control
 * 2 : w/o Cruise Control

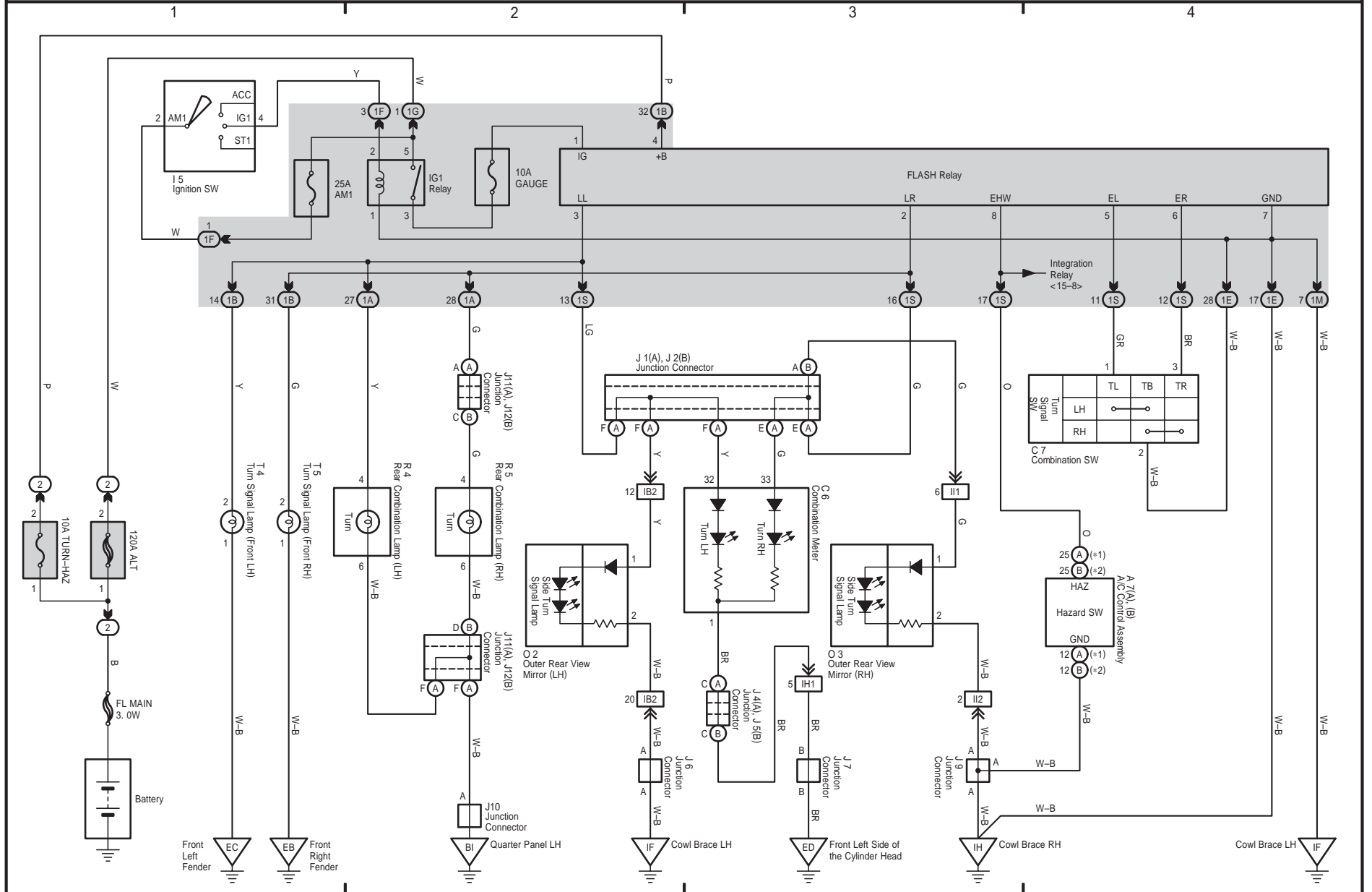

Power Source

Illumination

- * 1 : w/ Front Console Illumination
- * 2 : w/ Audio Steering Pad SW
- * 3 : w/ Cruise Control
- * 4 : w/o Cruise Control

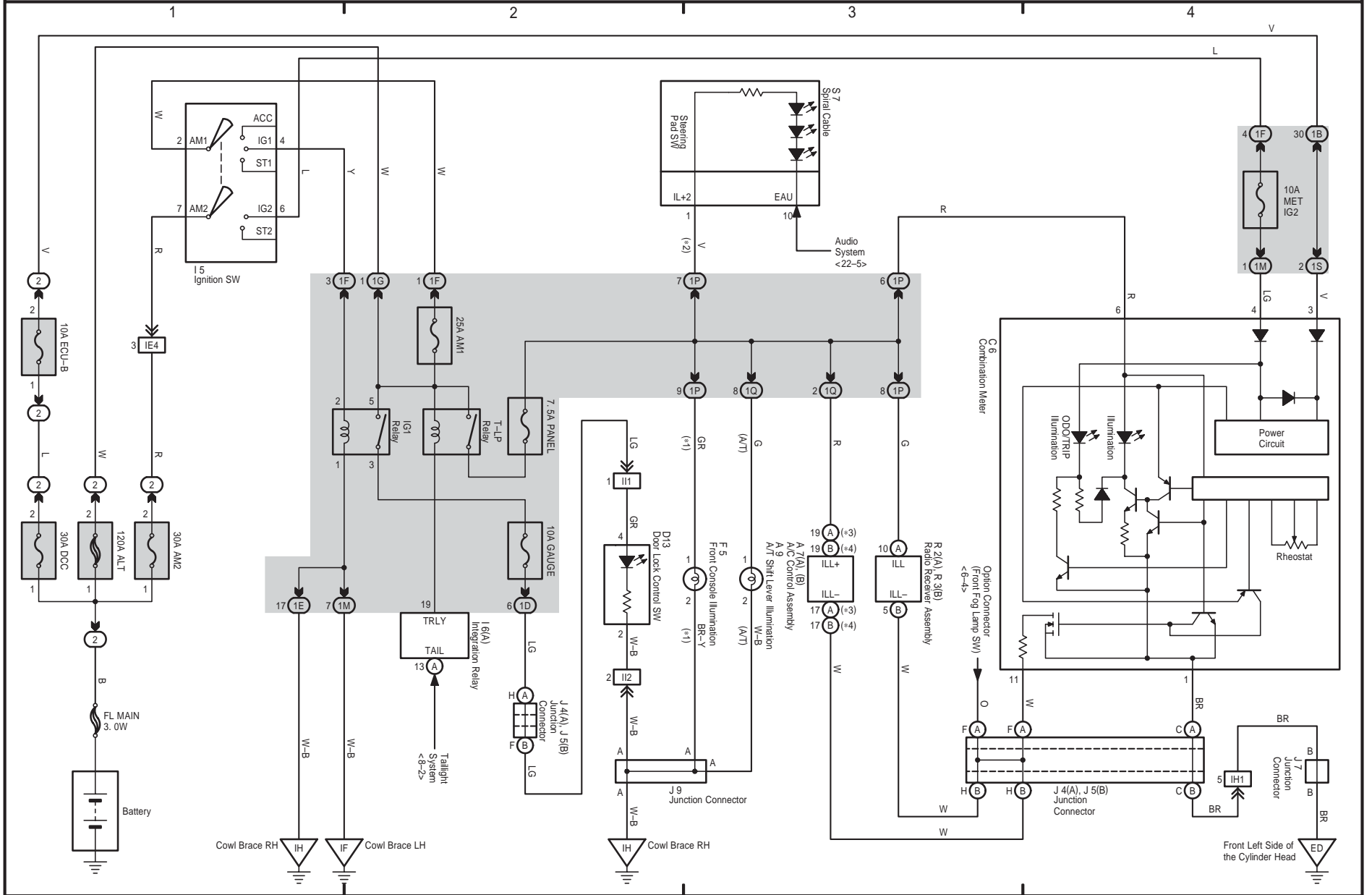

OVERALL ELECTRICAL WIRING DIAGRAM

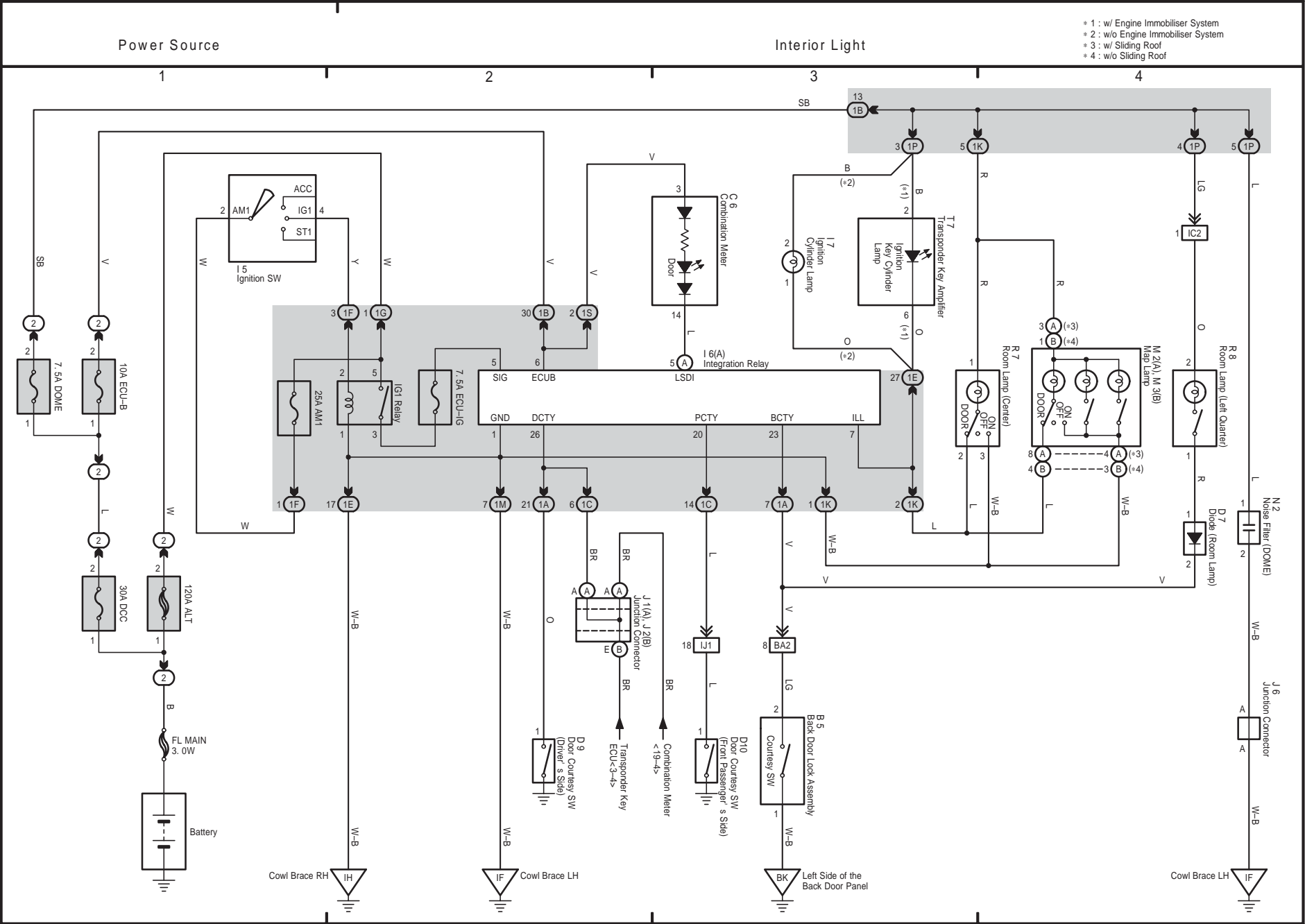

10 tC

230

SCION tC (EM0300U)

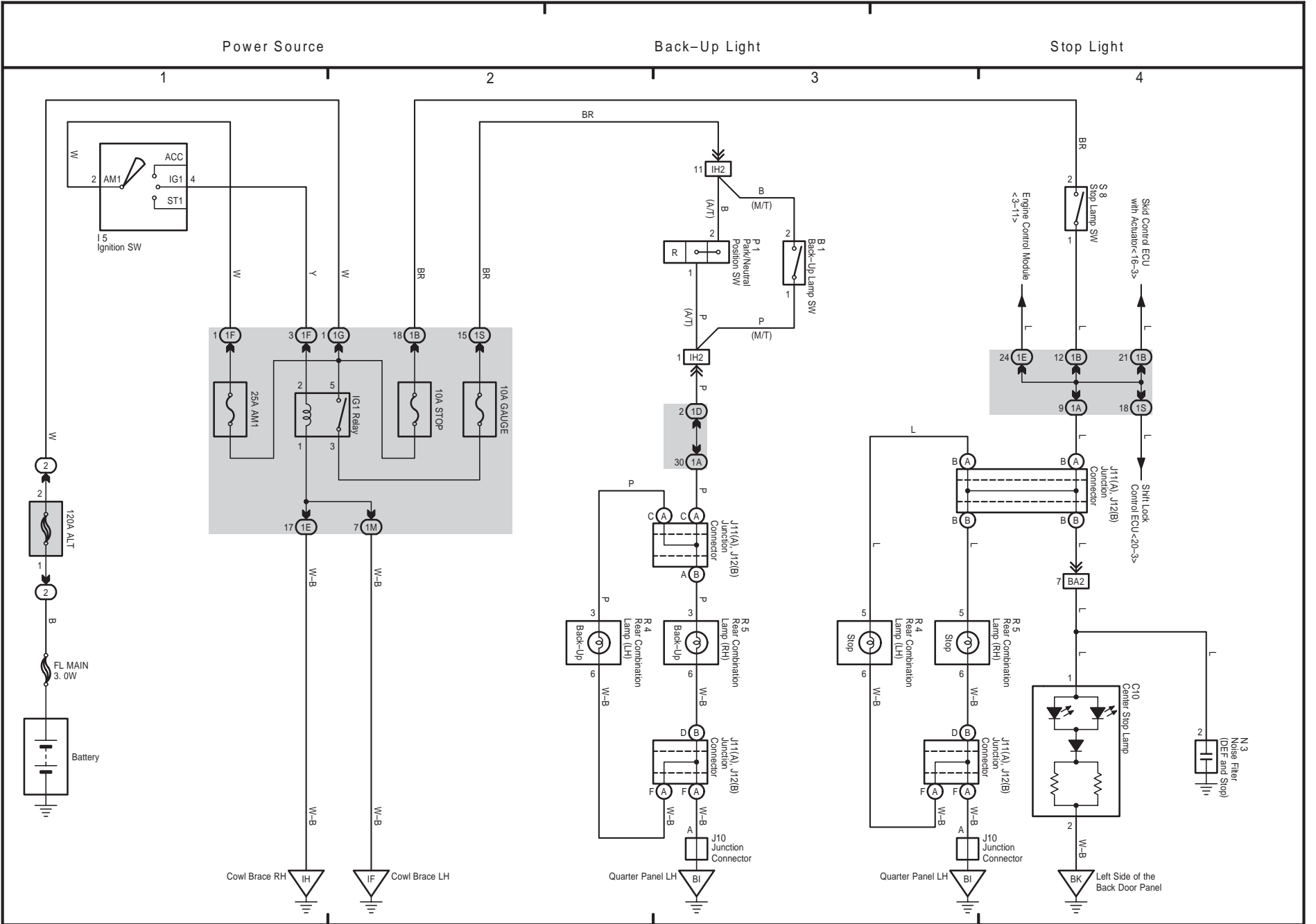

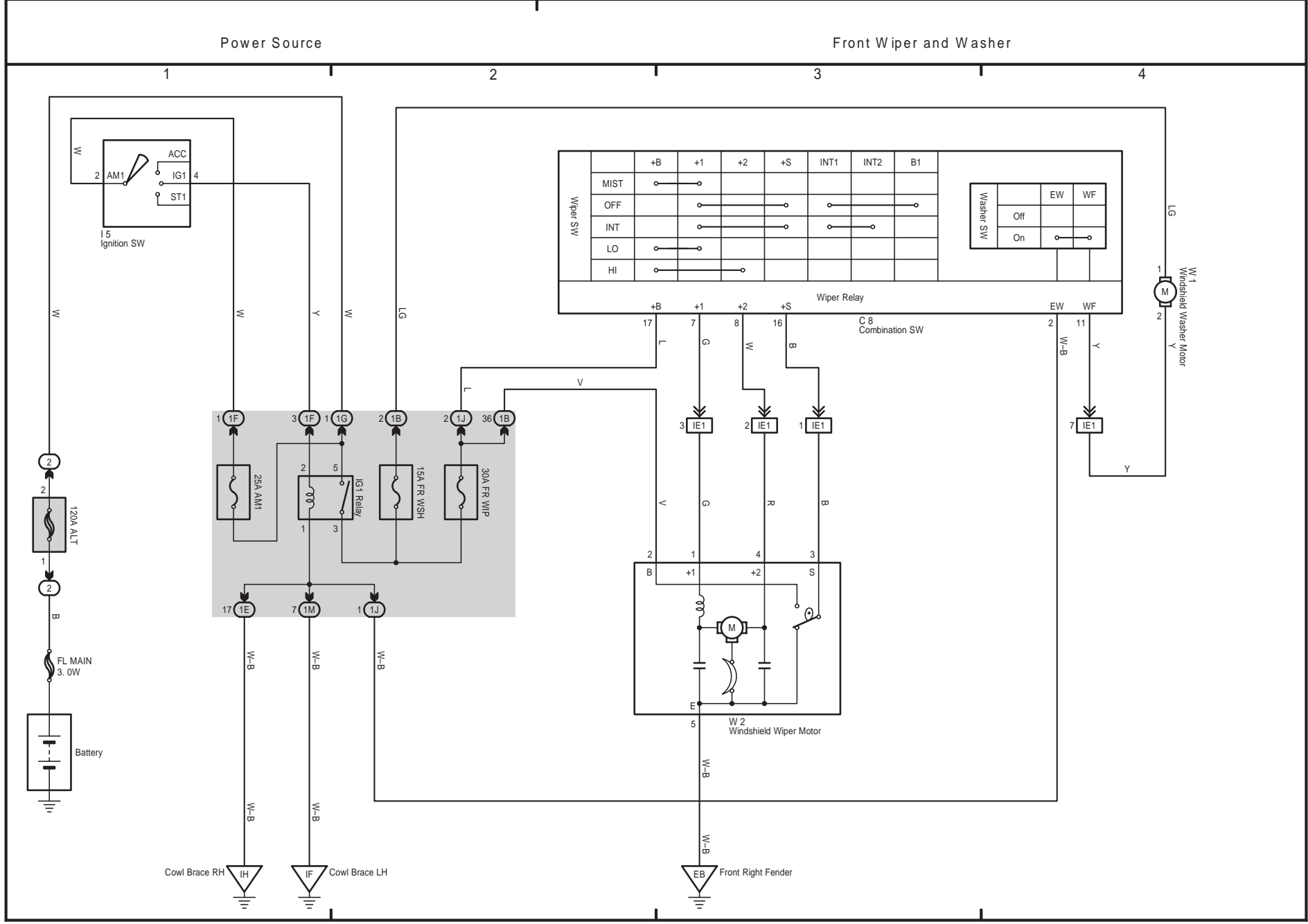

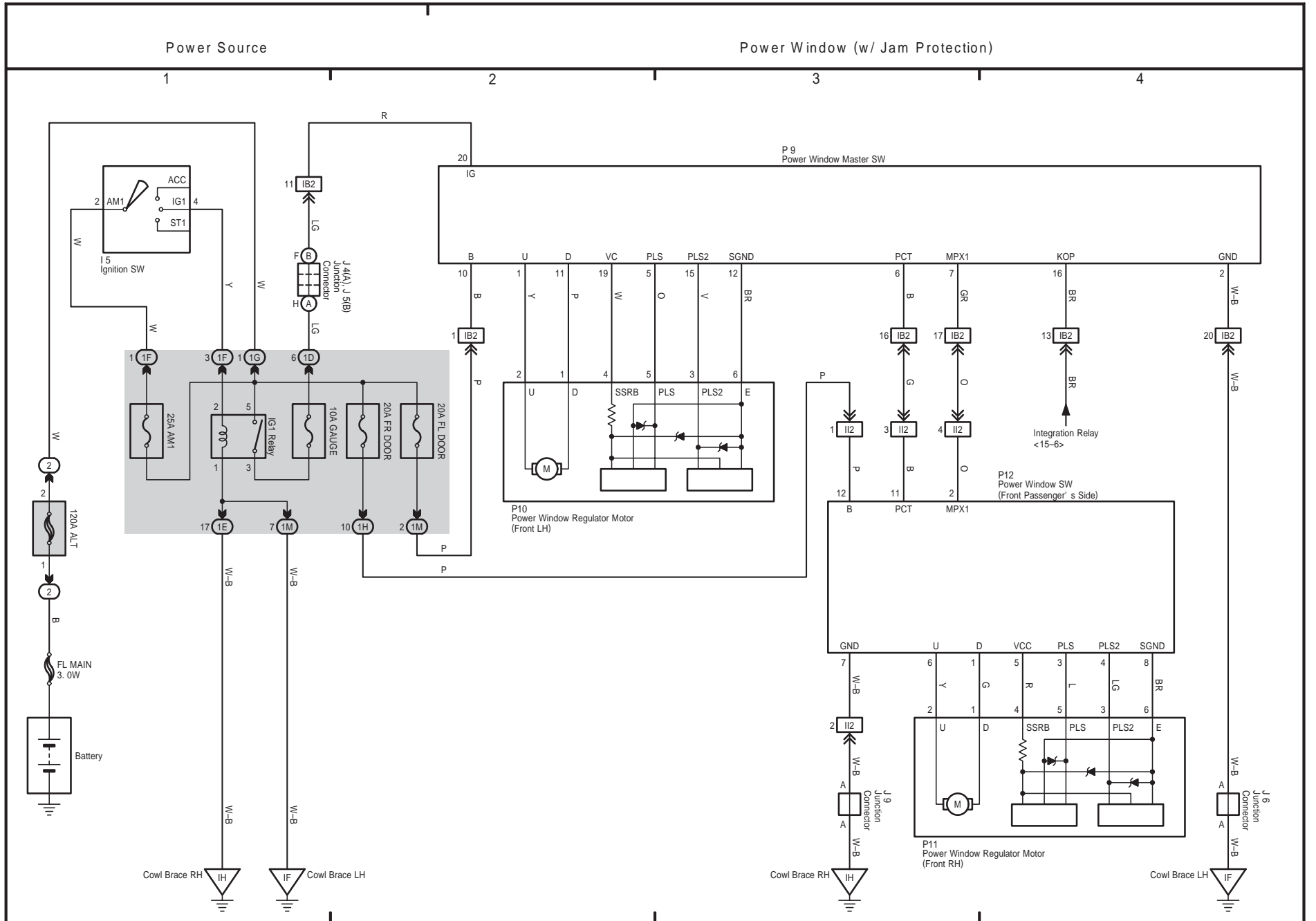

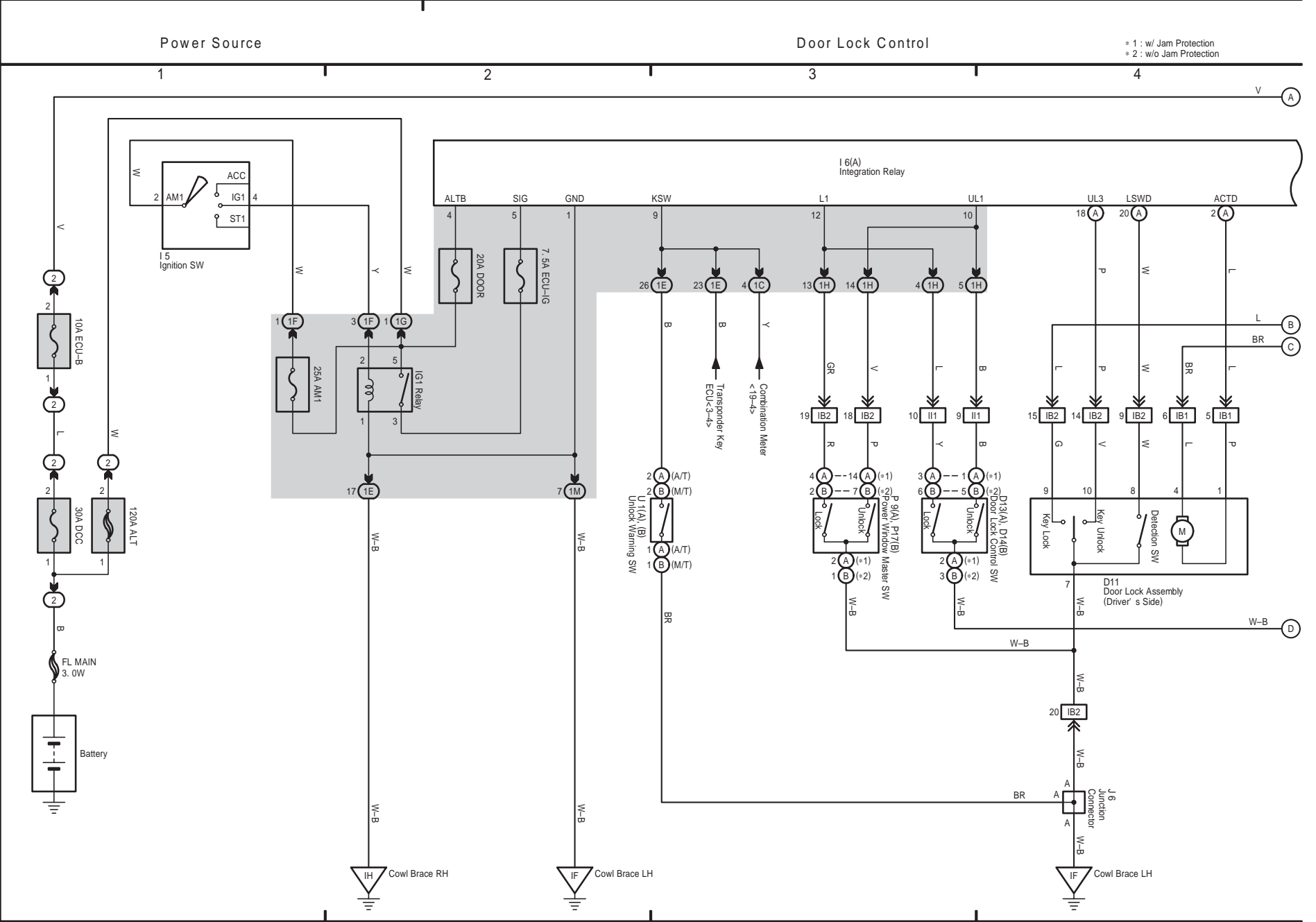

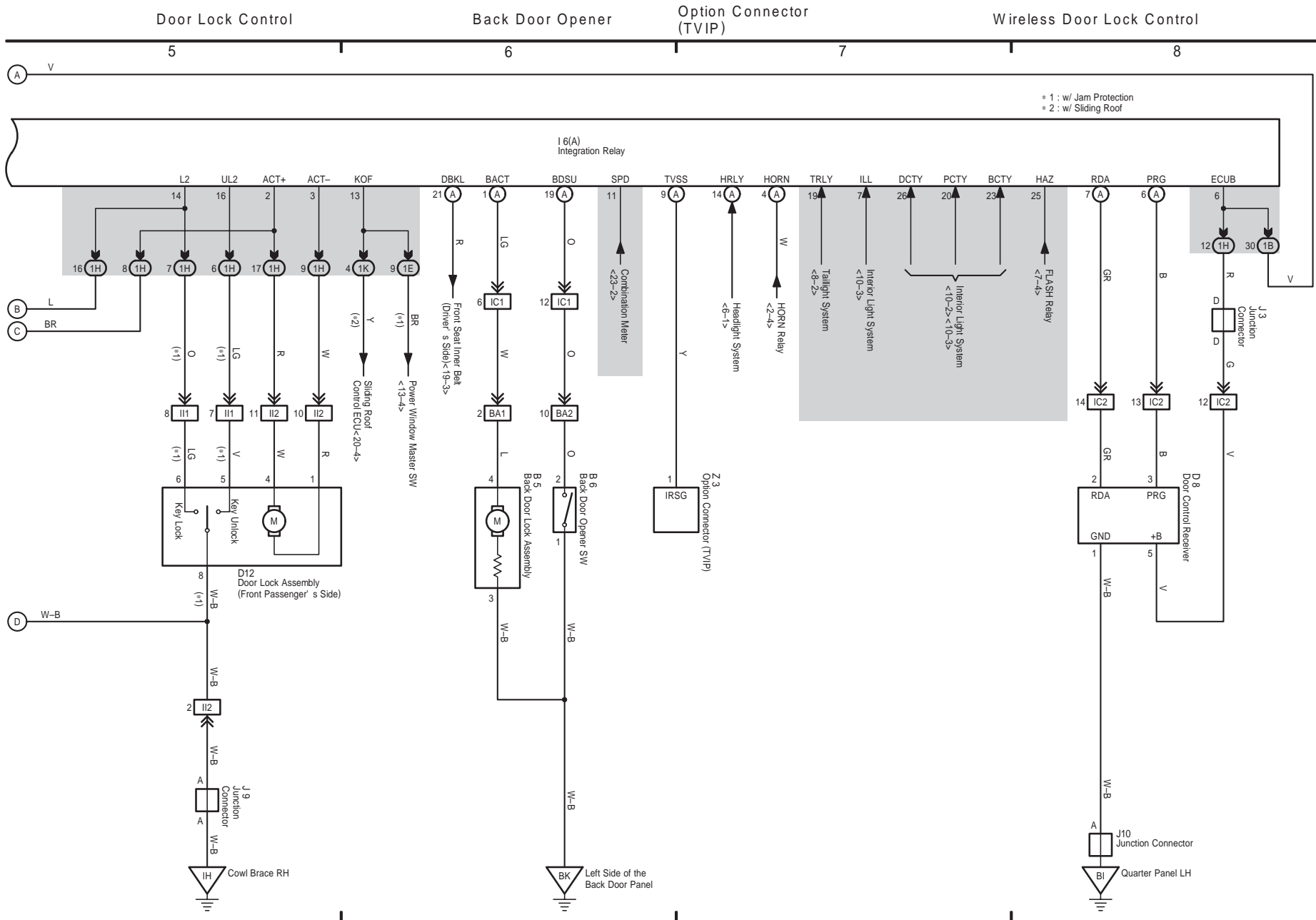

SCION tC (EM0300U)



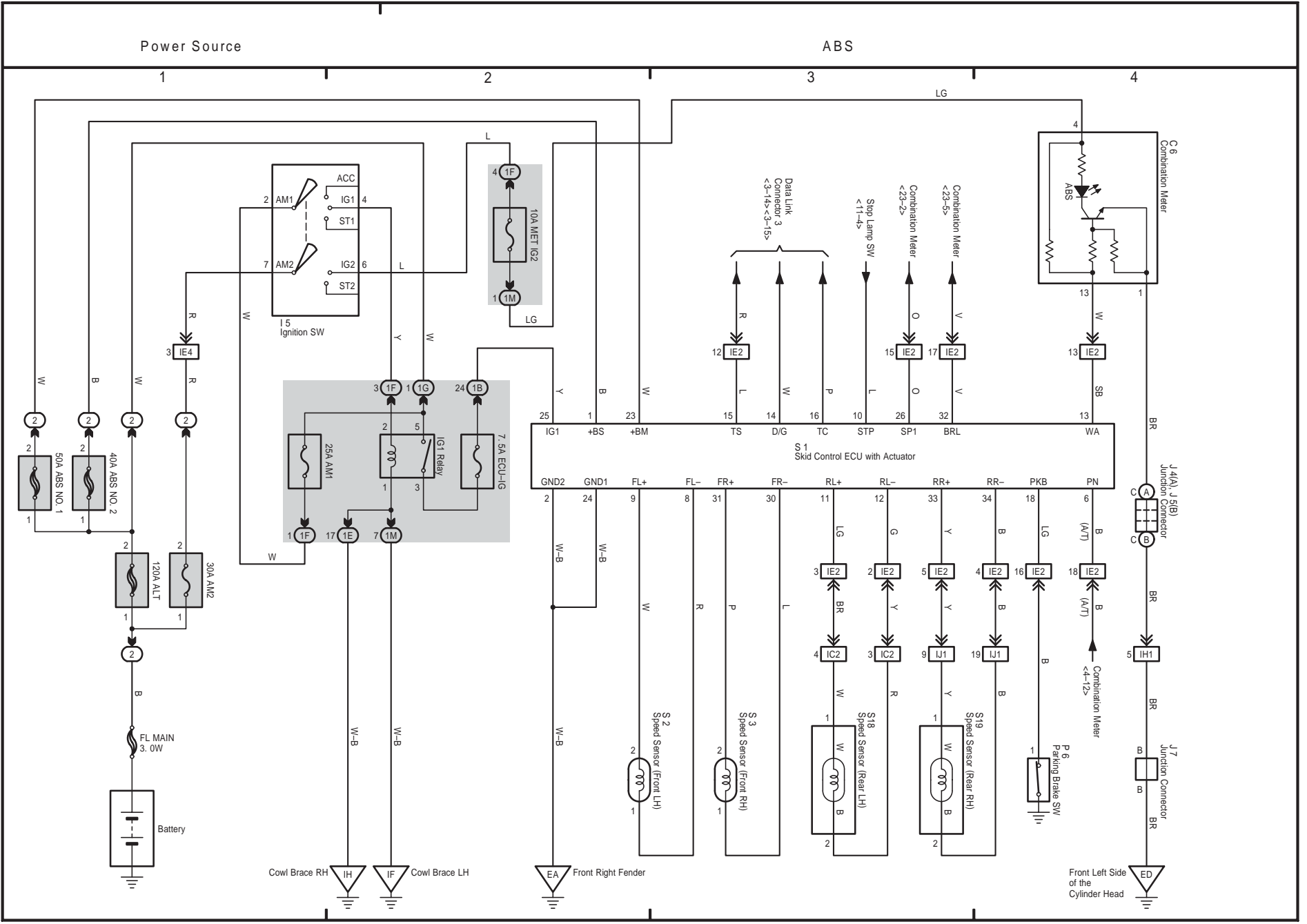

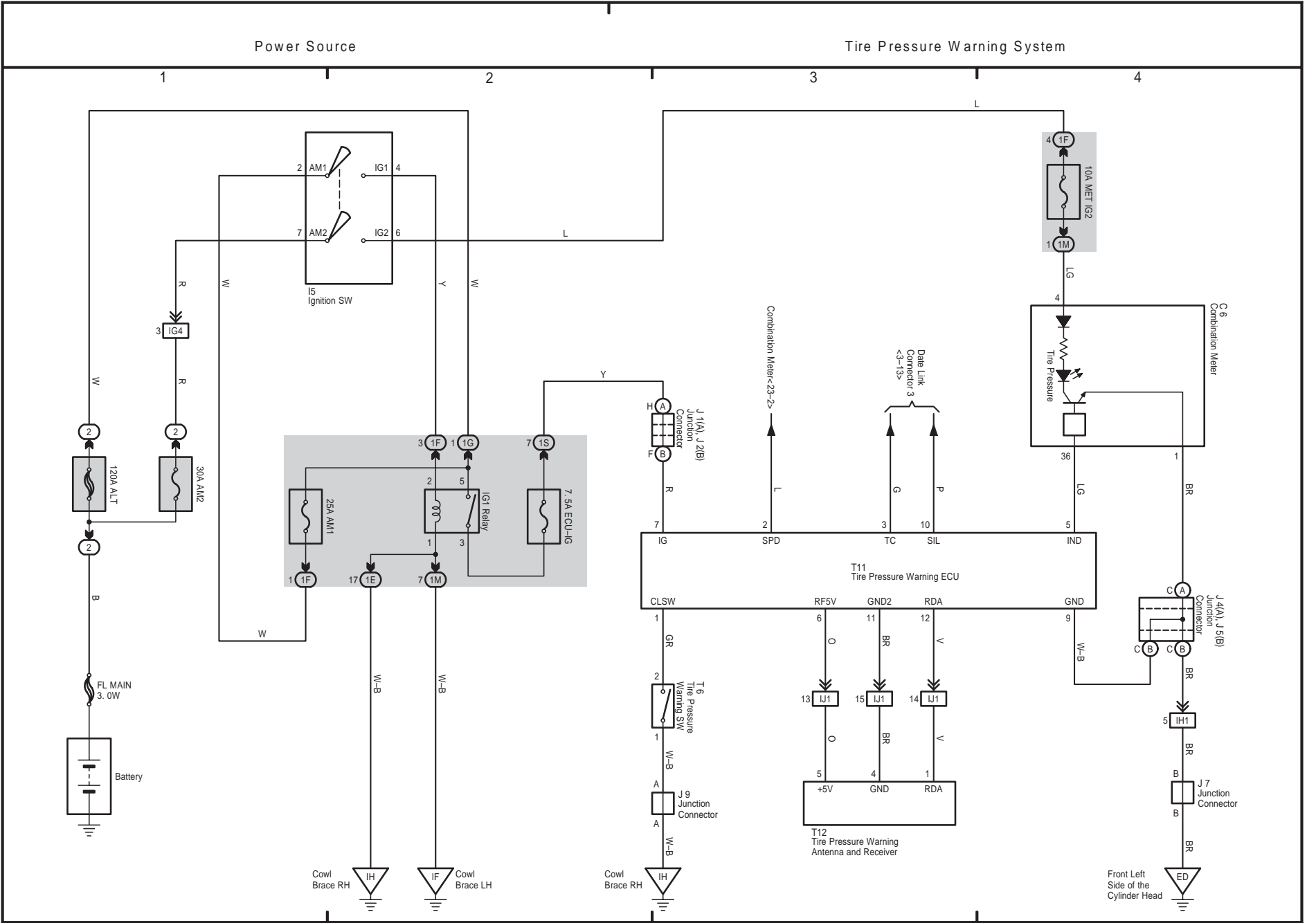

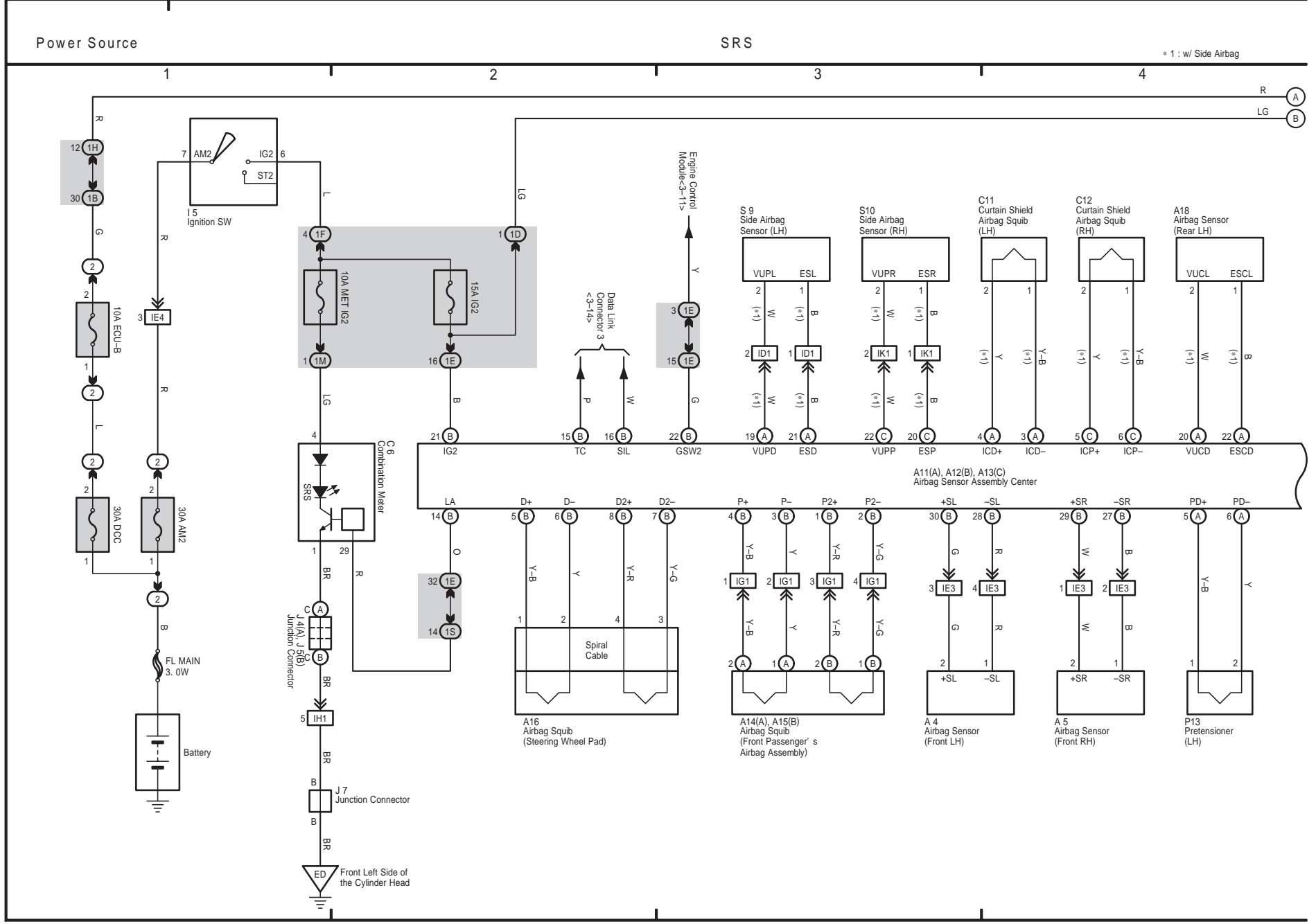

SRS

- * 1 : w/ Side Airbag
- * 2 : w/ Cruise Control
- * 3 : w/o Cruise Control

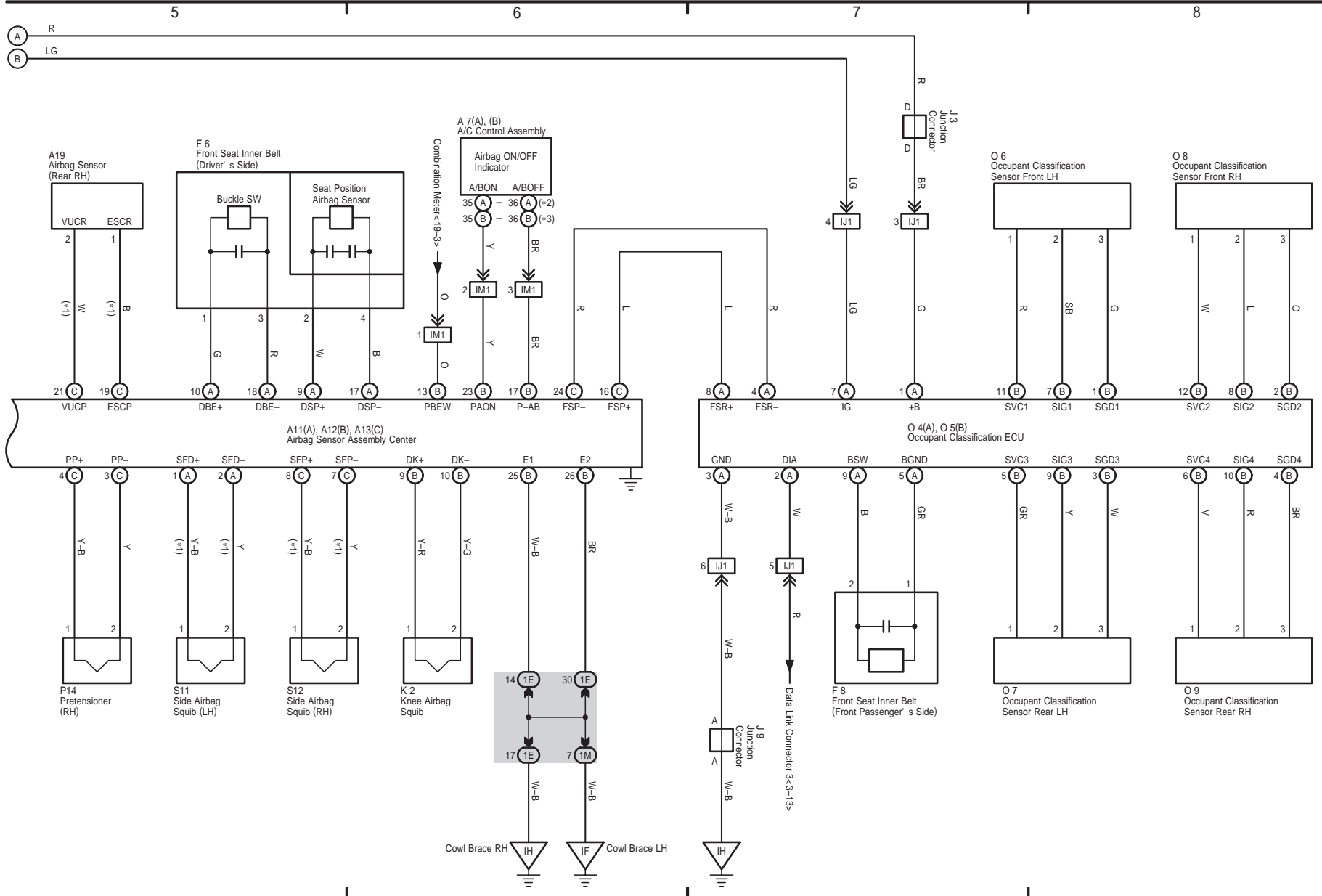

SCION tC (EM0300U)

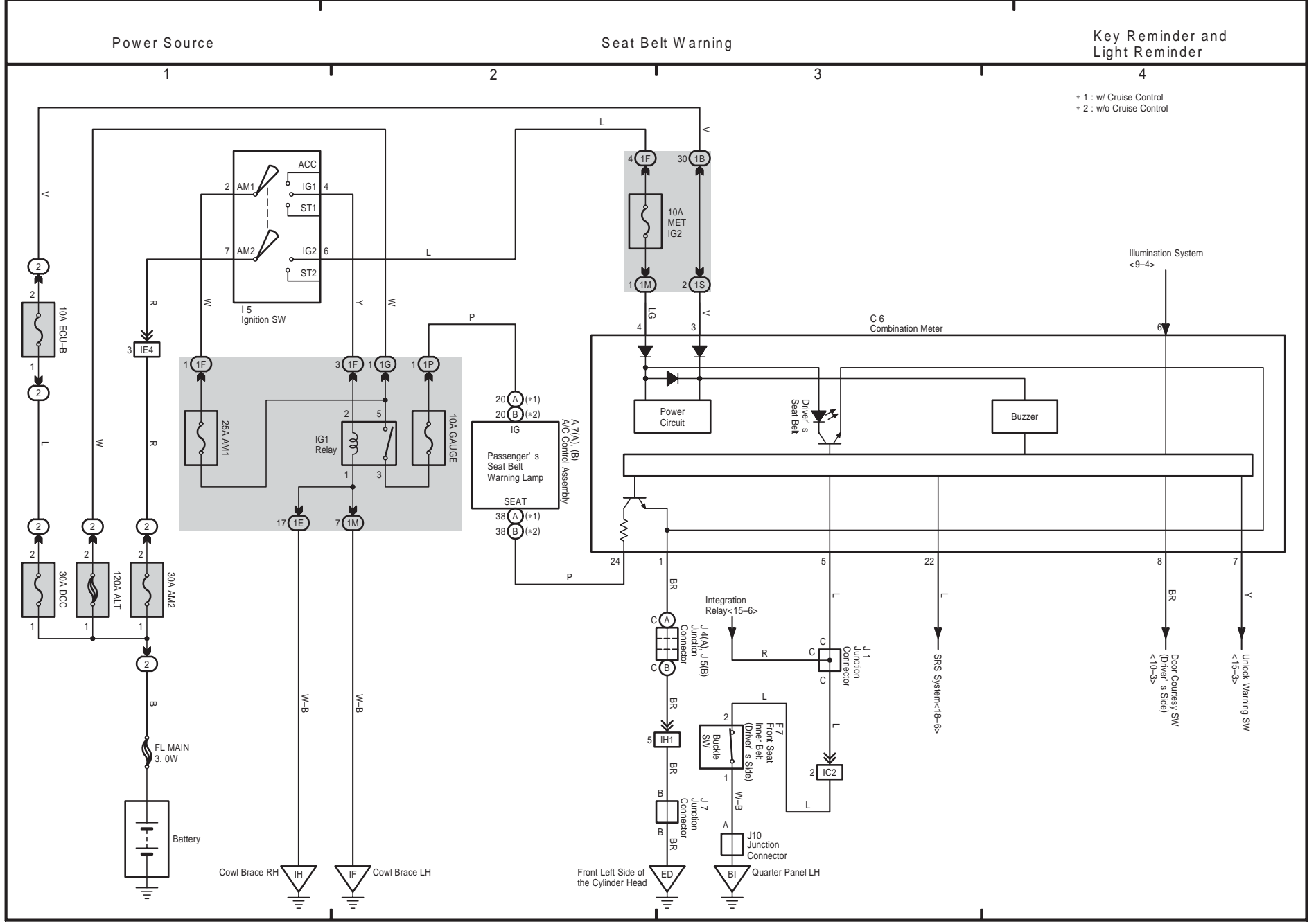

Power Source

Shift Lock

Sliding Roof

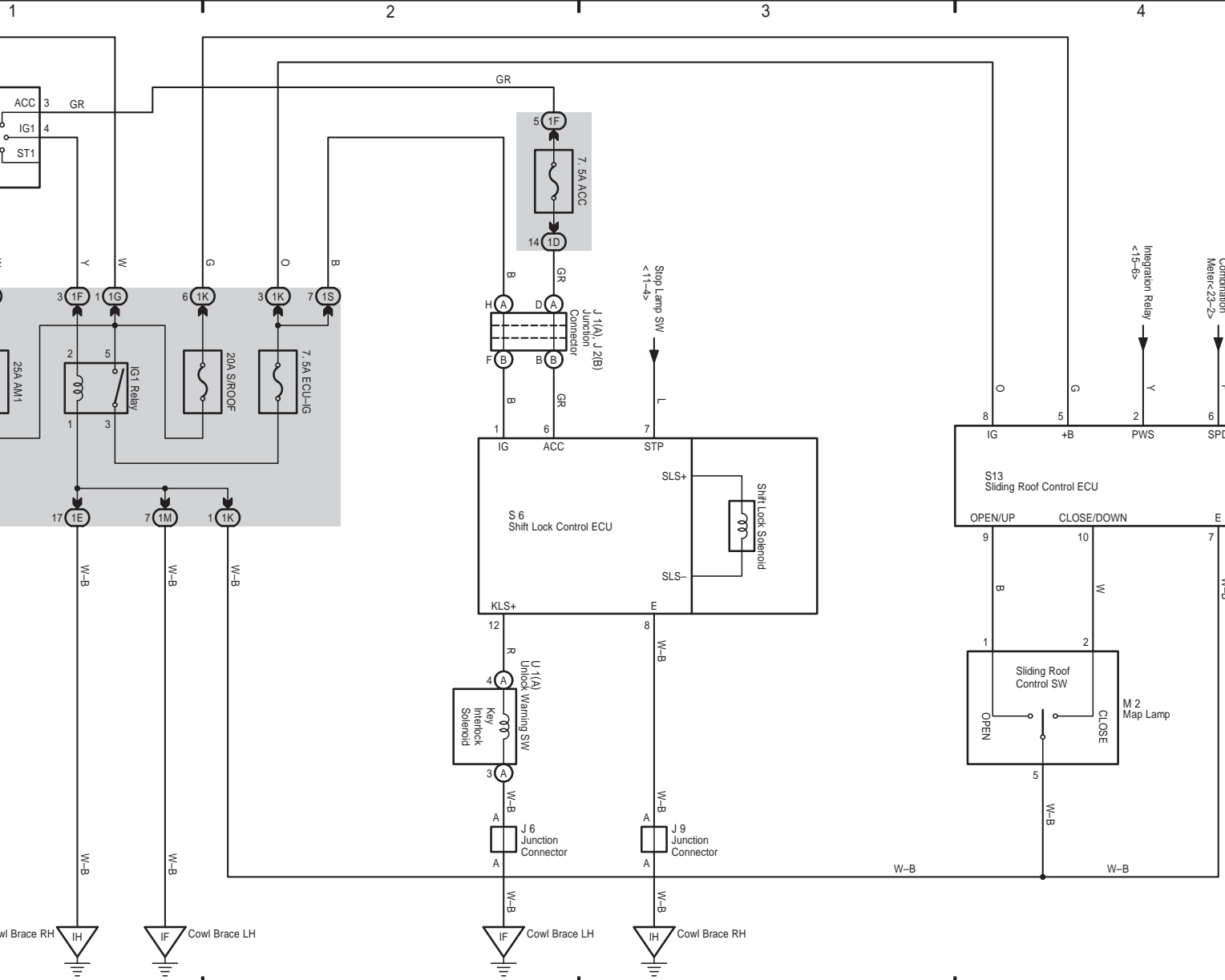

SCION tC (EM0300U)



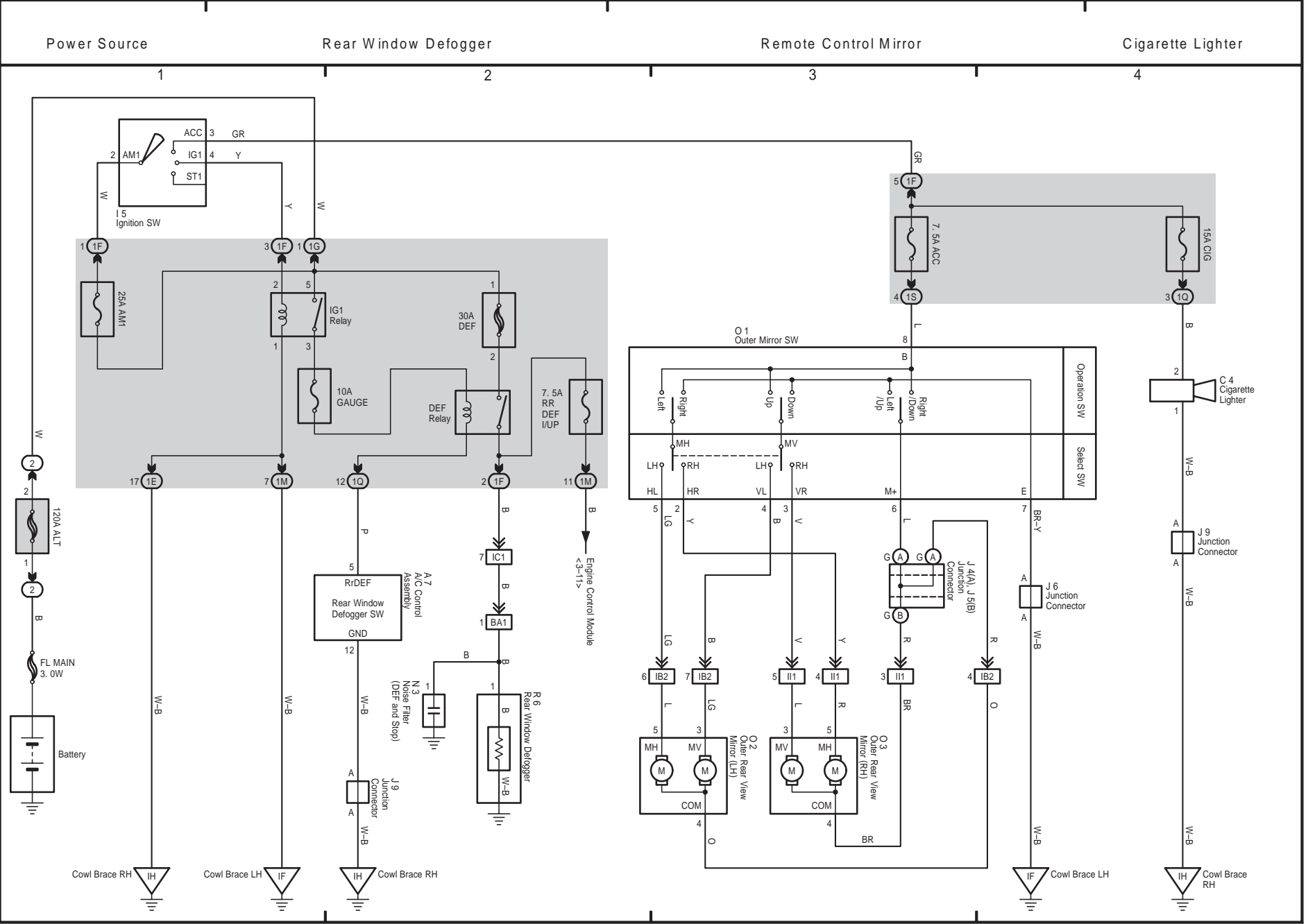

OVERALL ELECTRICAL WIRING DIAGRAM

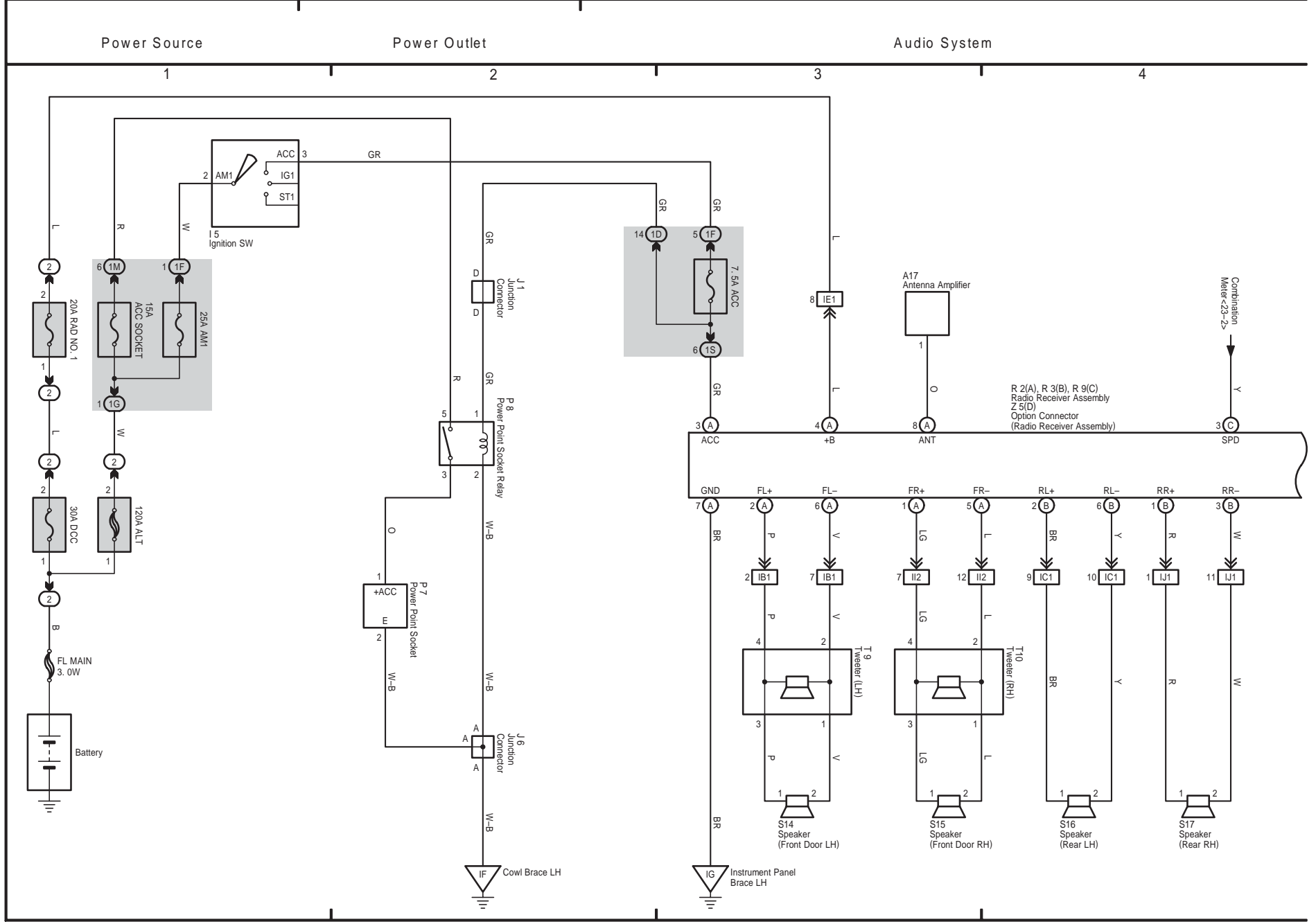

Audio System

5

6

7

8

* 1 : w/ Audio Steering Pad SW

Z 4
Option Connector (IPOD Unit)

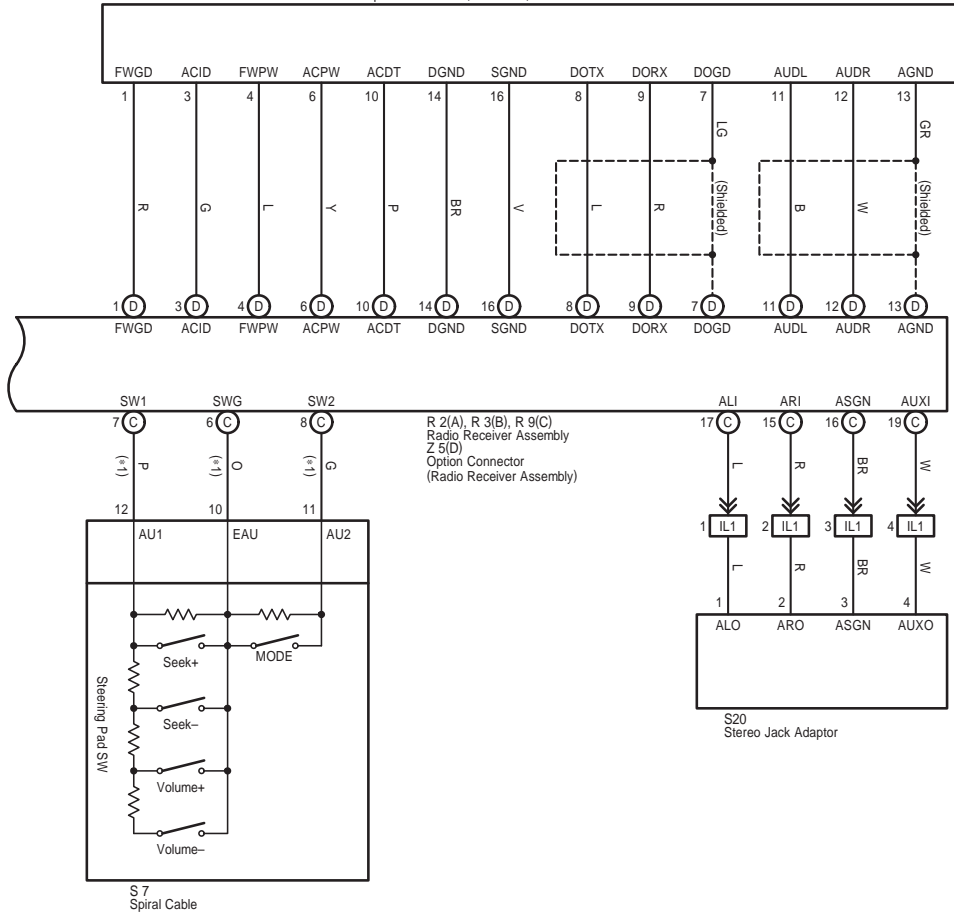

SCION tC (EM0300U)

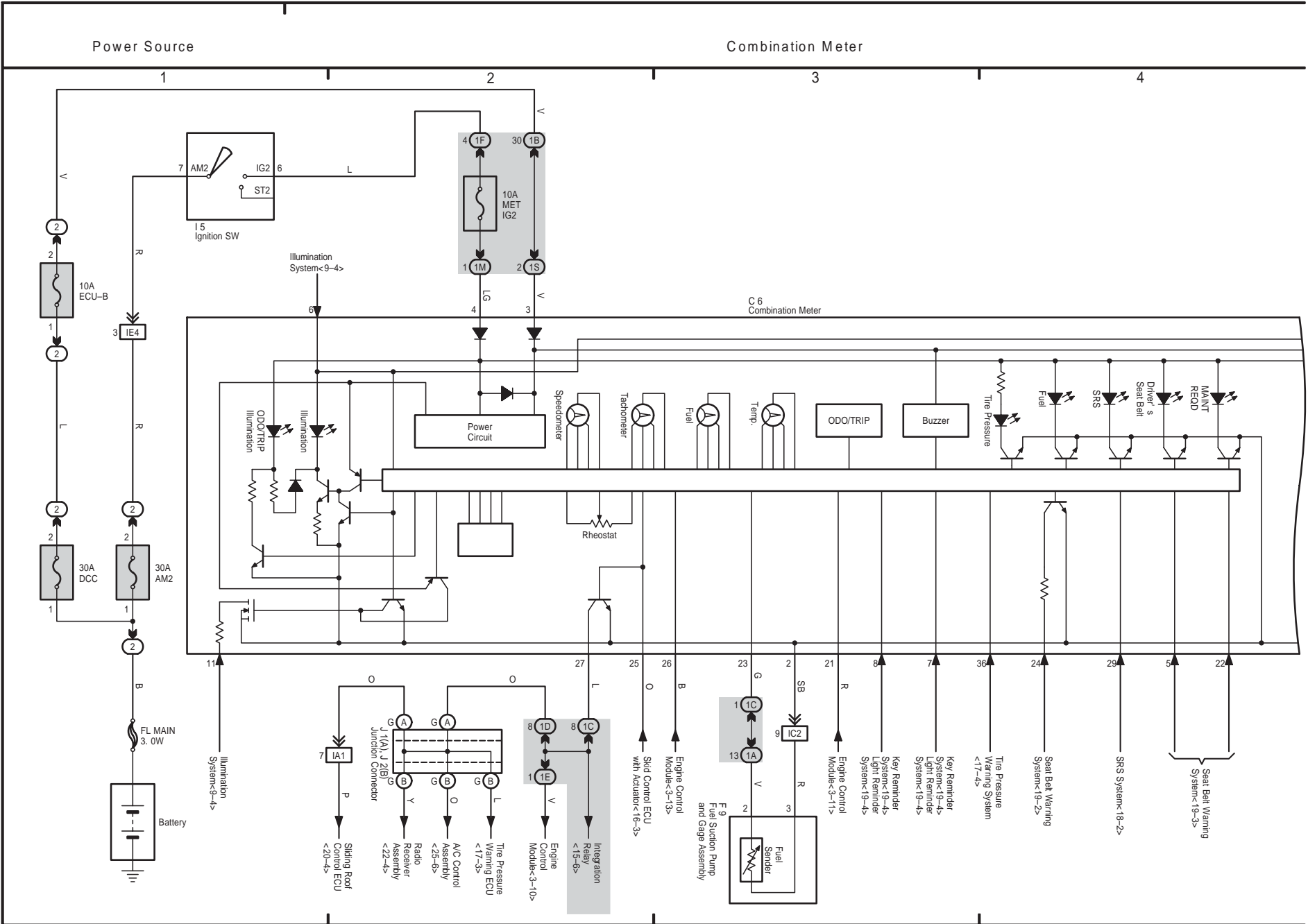

SCION tC (EM0300U)

Combination Meter

5

6

7

8

SCION tC (EM0300U)

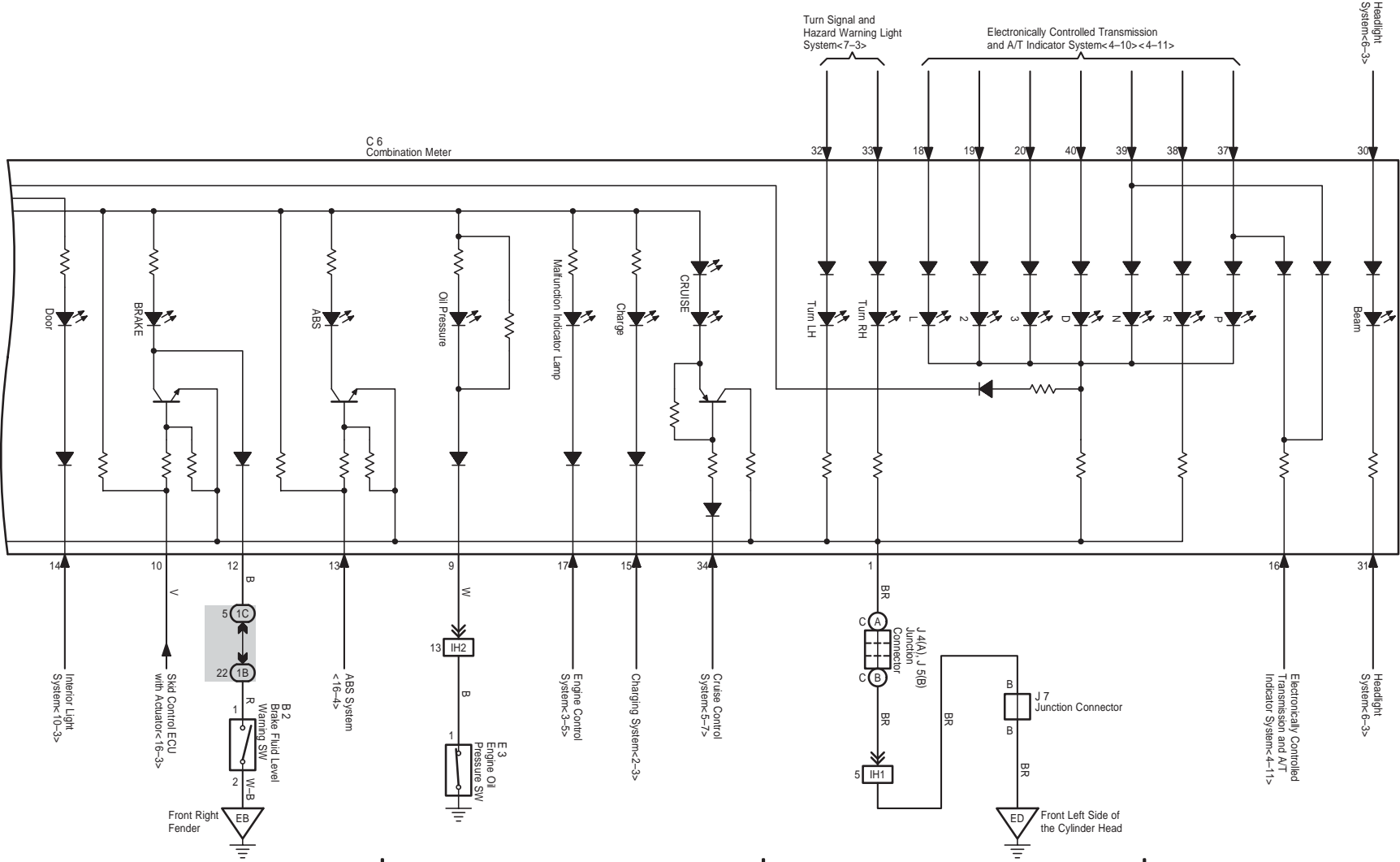

M OVERALL ELECTRICAL WIRING DIAGRAM

24 tC

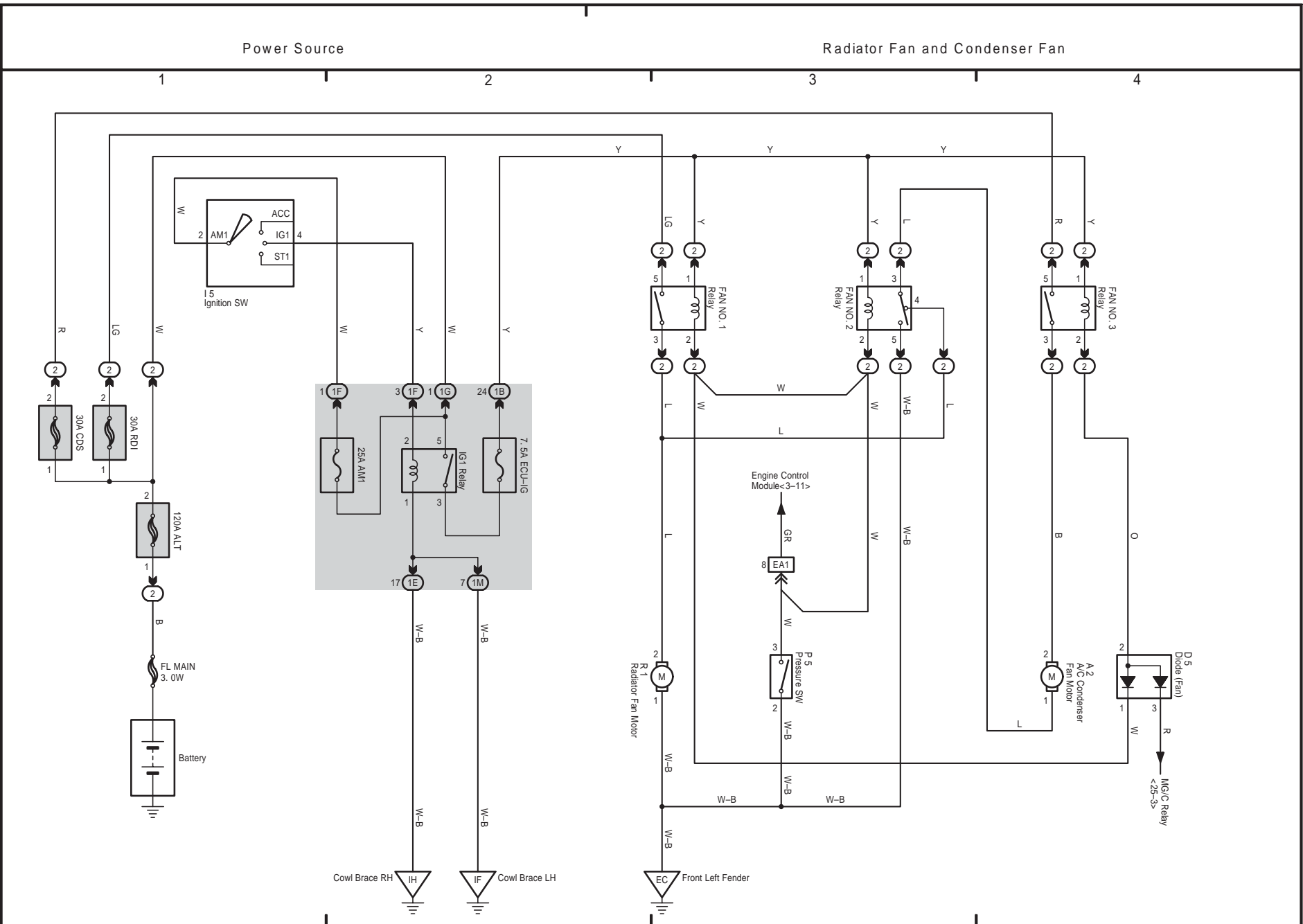

250

SCION tC (EM0300U)

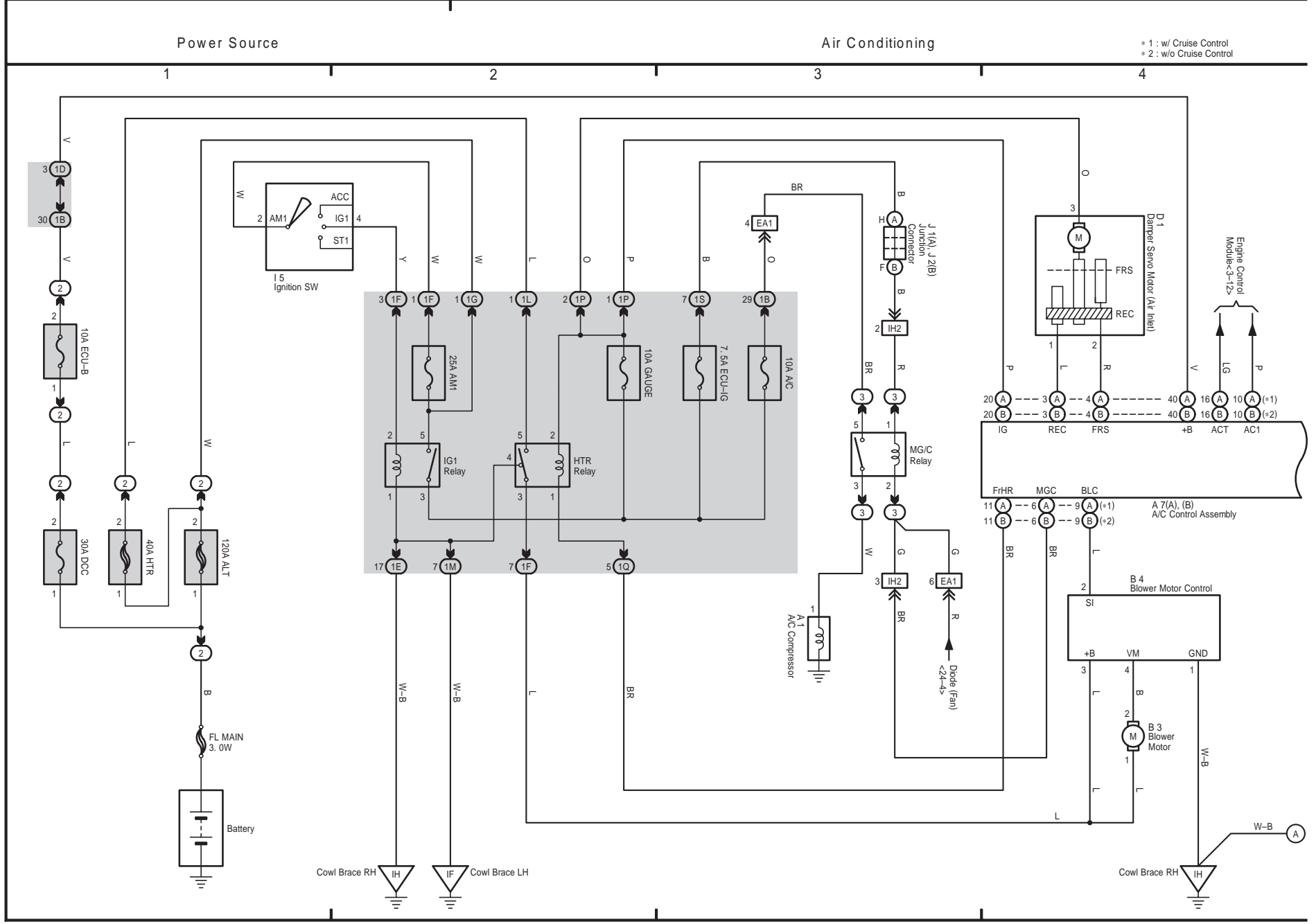

Air Conditioning

* 1 : w/ Cruise Control
 * 2 : w/o Cruise Control

5 6 7 8

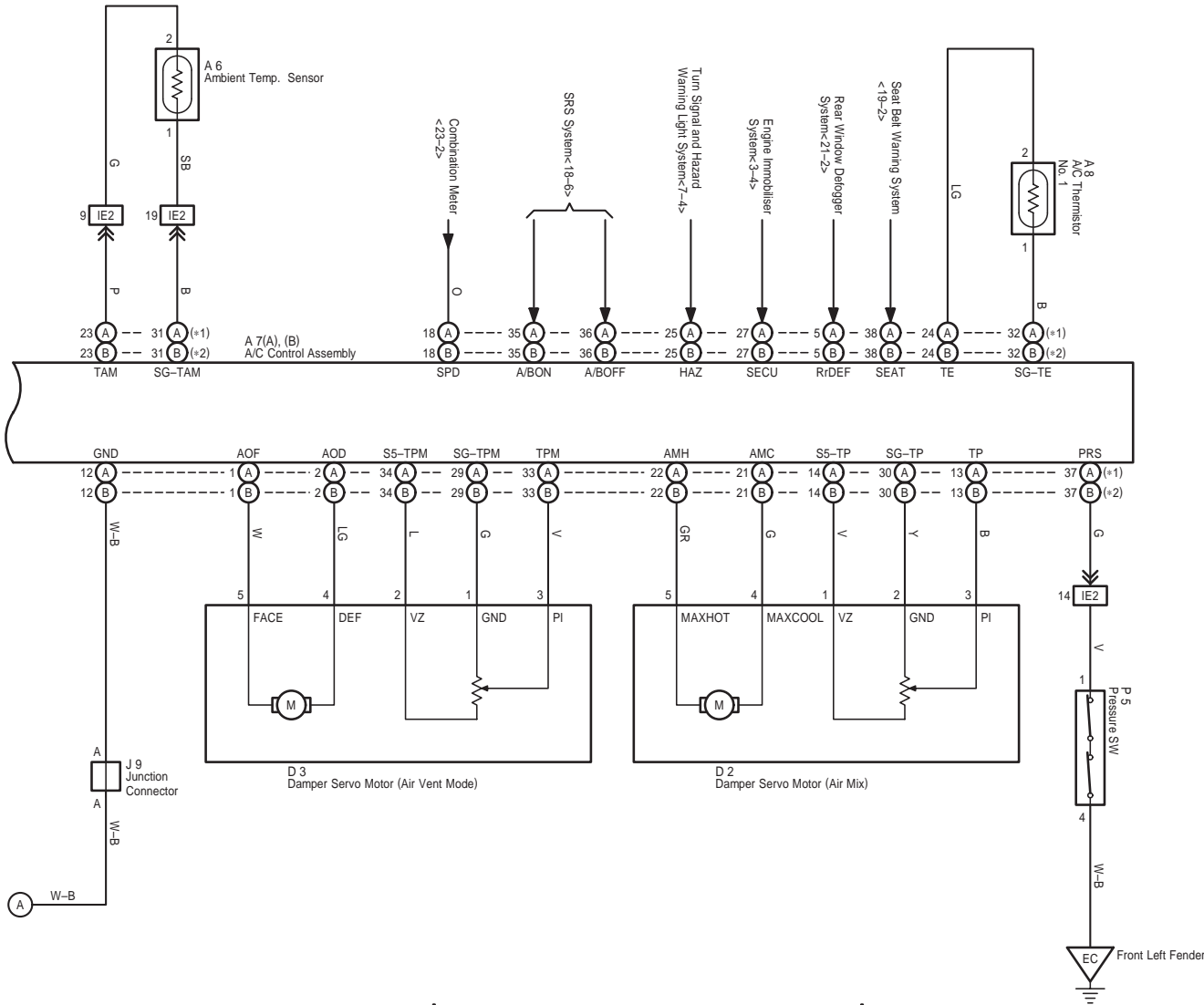

SCION tC (EM0300U)