

ABS , TRAC , VSC

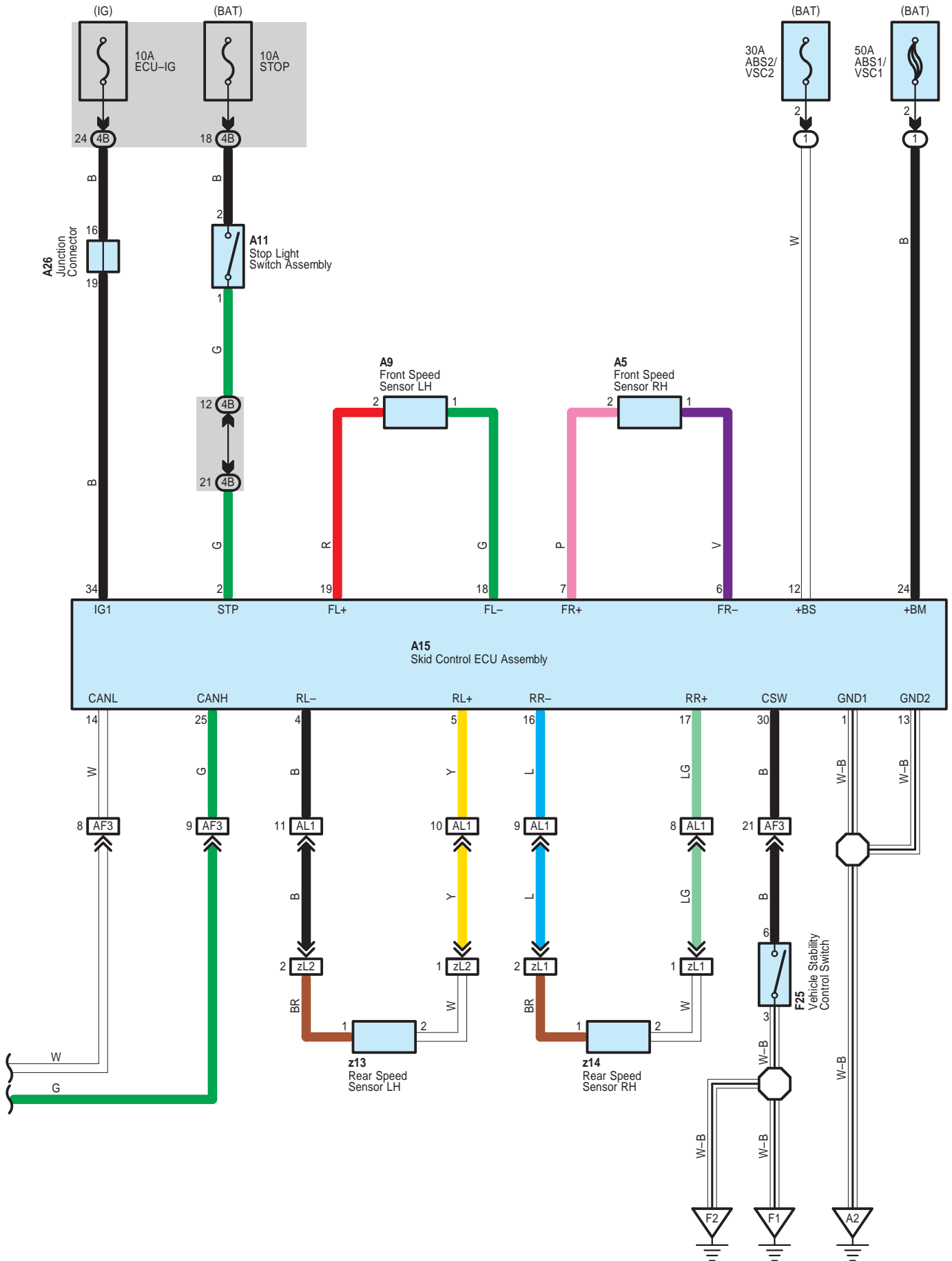

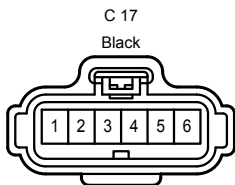

C 19
Black

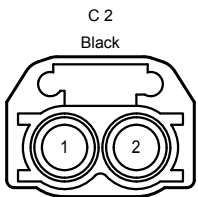
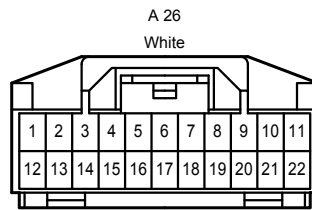
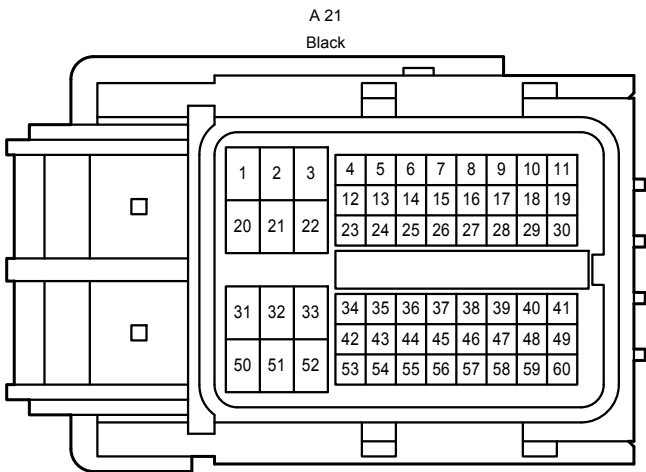
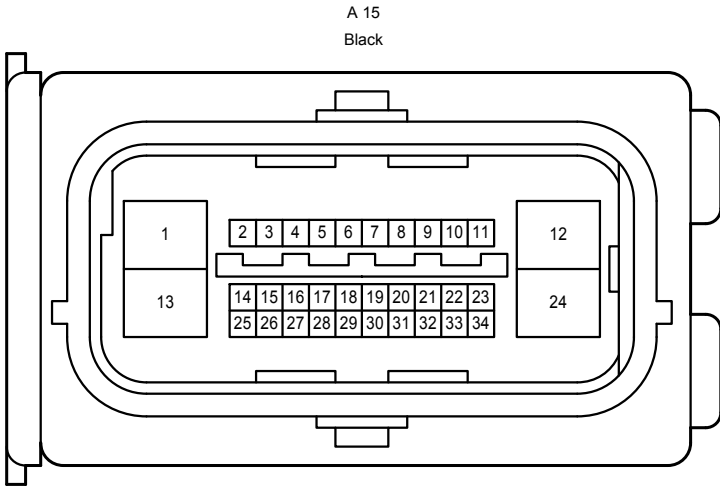
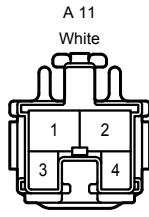
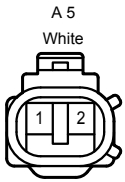
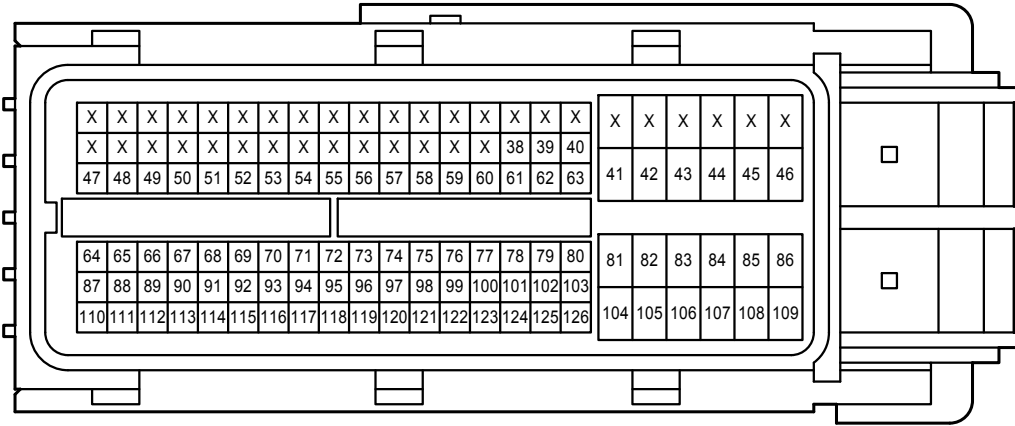

C 28
Gray

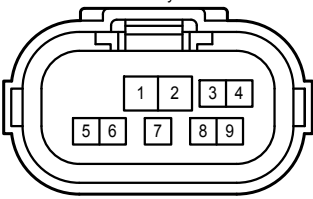

F 1
White

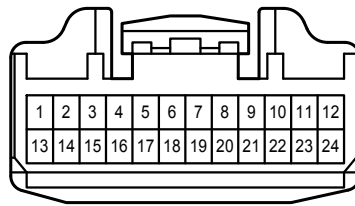

F 2
White

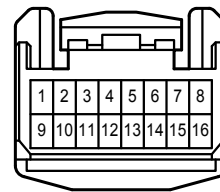

F 16
White

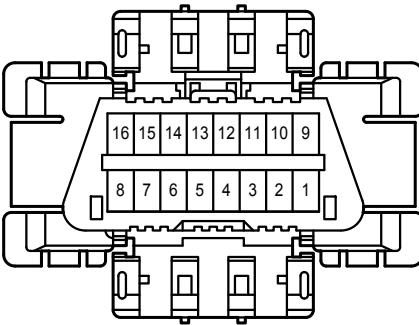

F 25
White

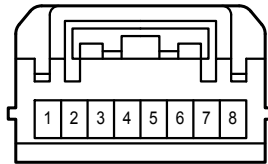

F 33
Black

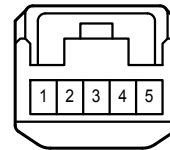

F 34
Black

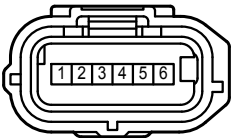

F 41
White

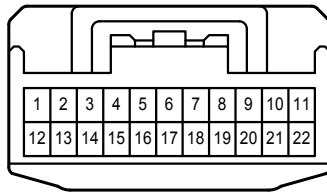

F 42
White

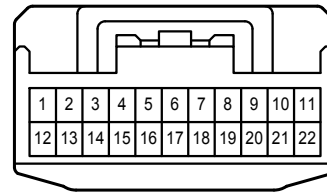

F 45
White

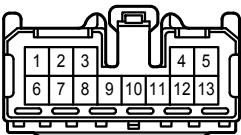

F 46
White

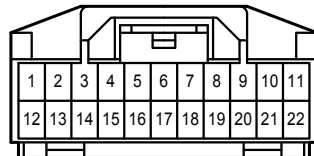

F 47
White

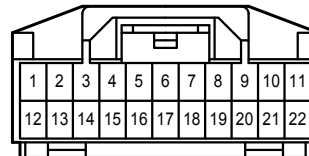

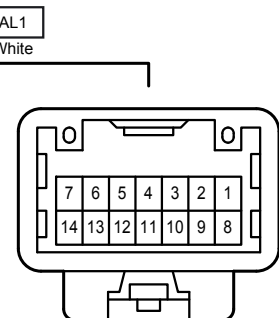
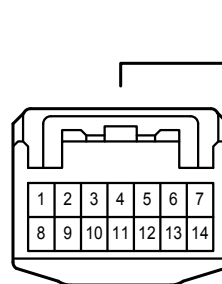
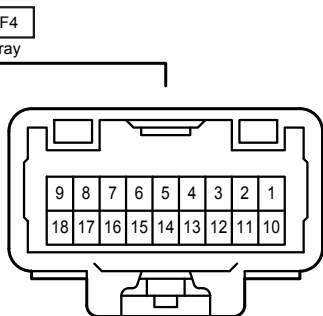
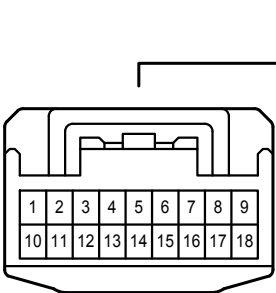
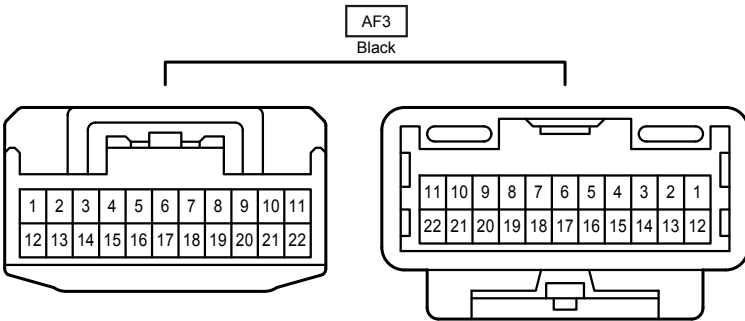
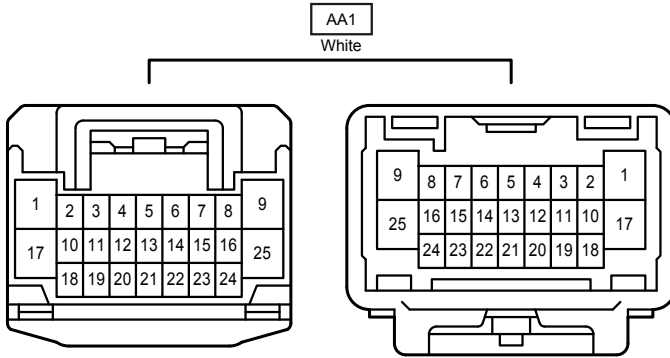
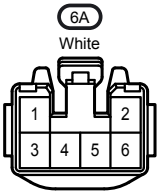
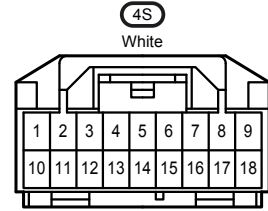
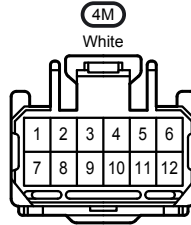
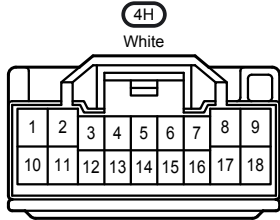
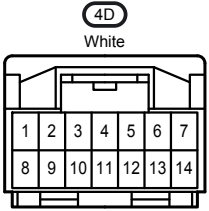
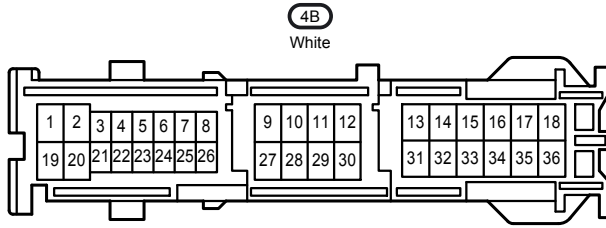
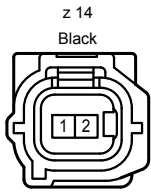
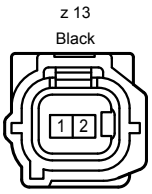

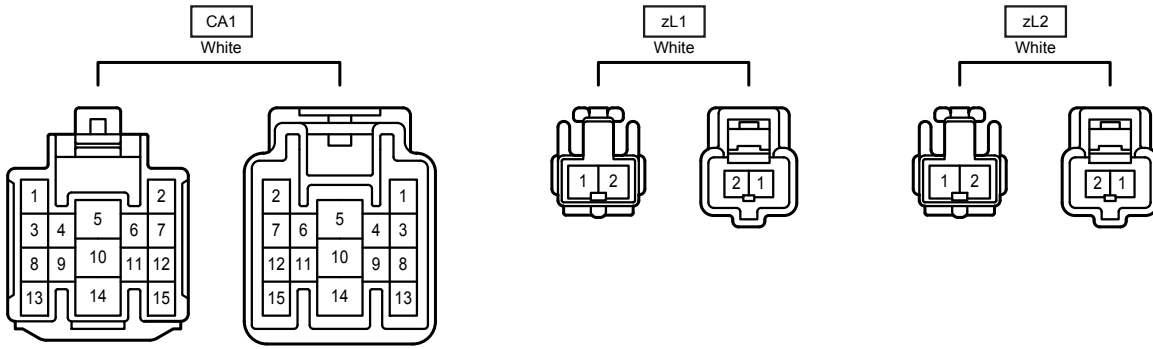

Air Conditioning

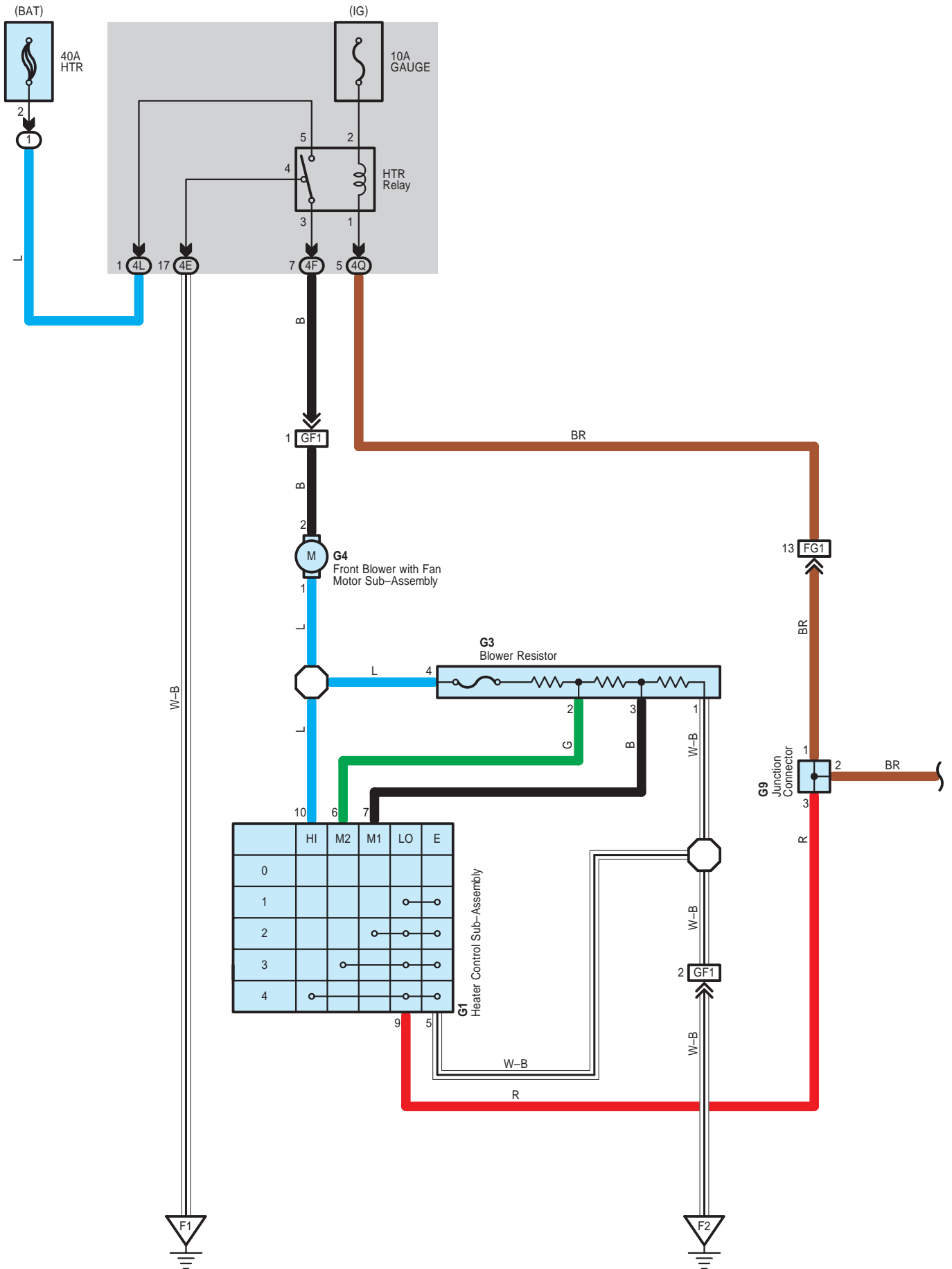

Air Conditioning

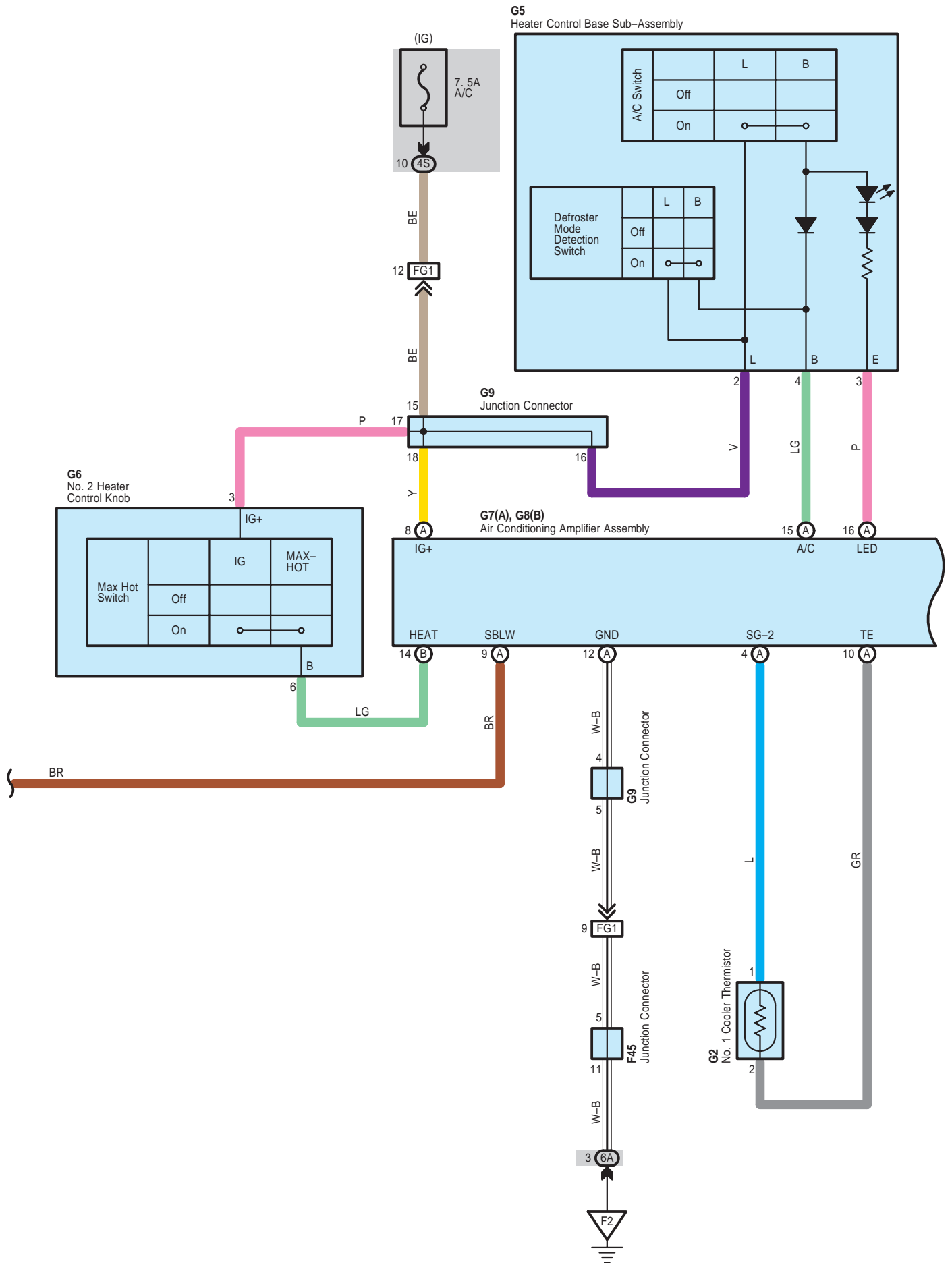

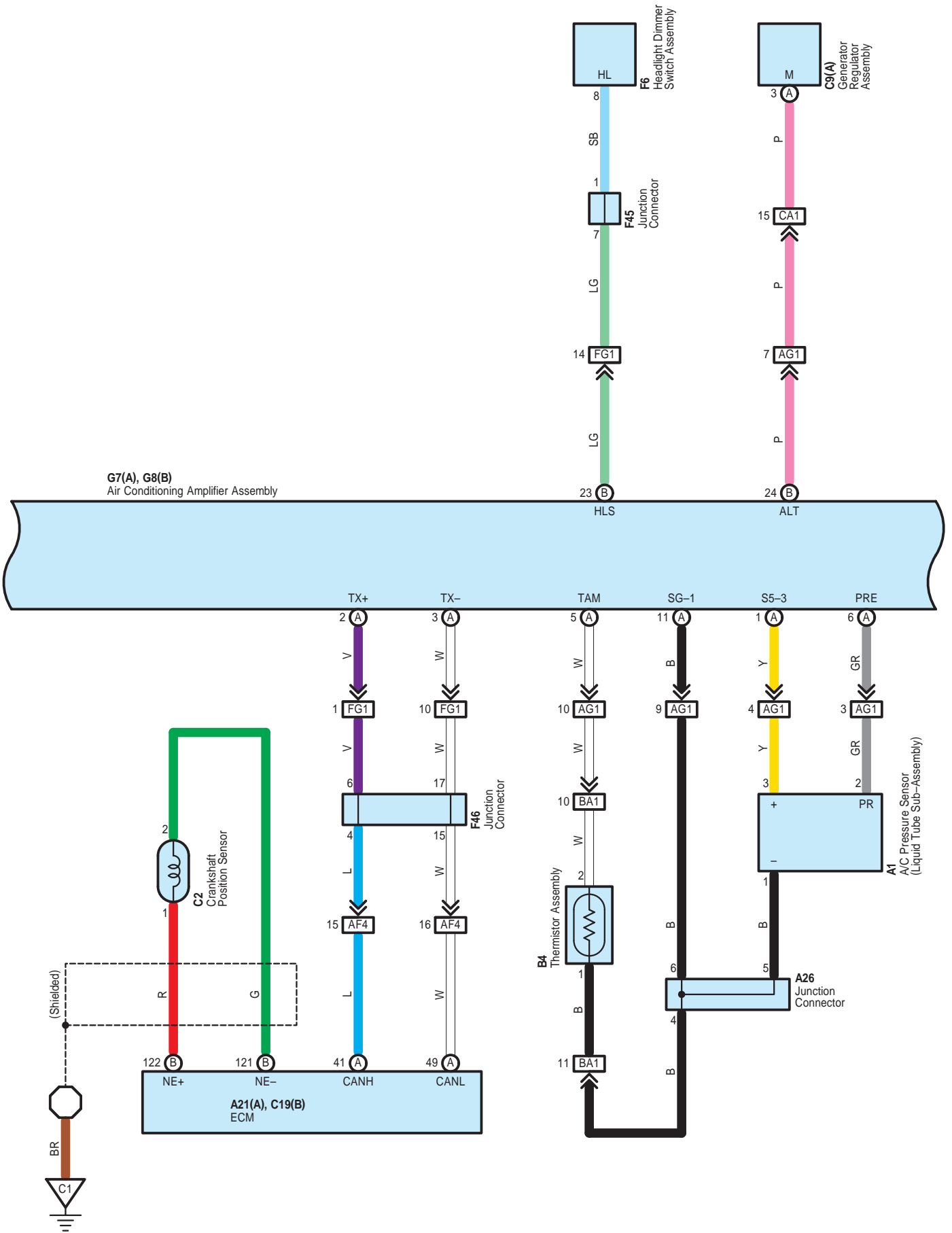

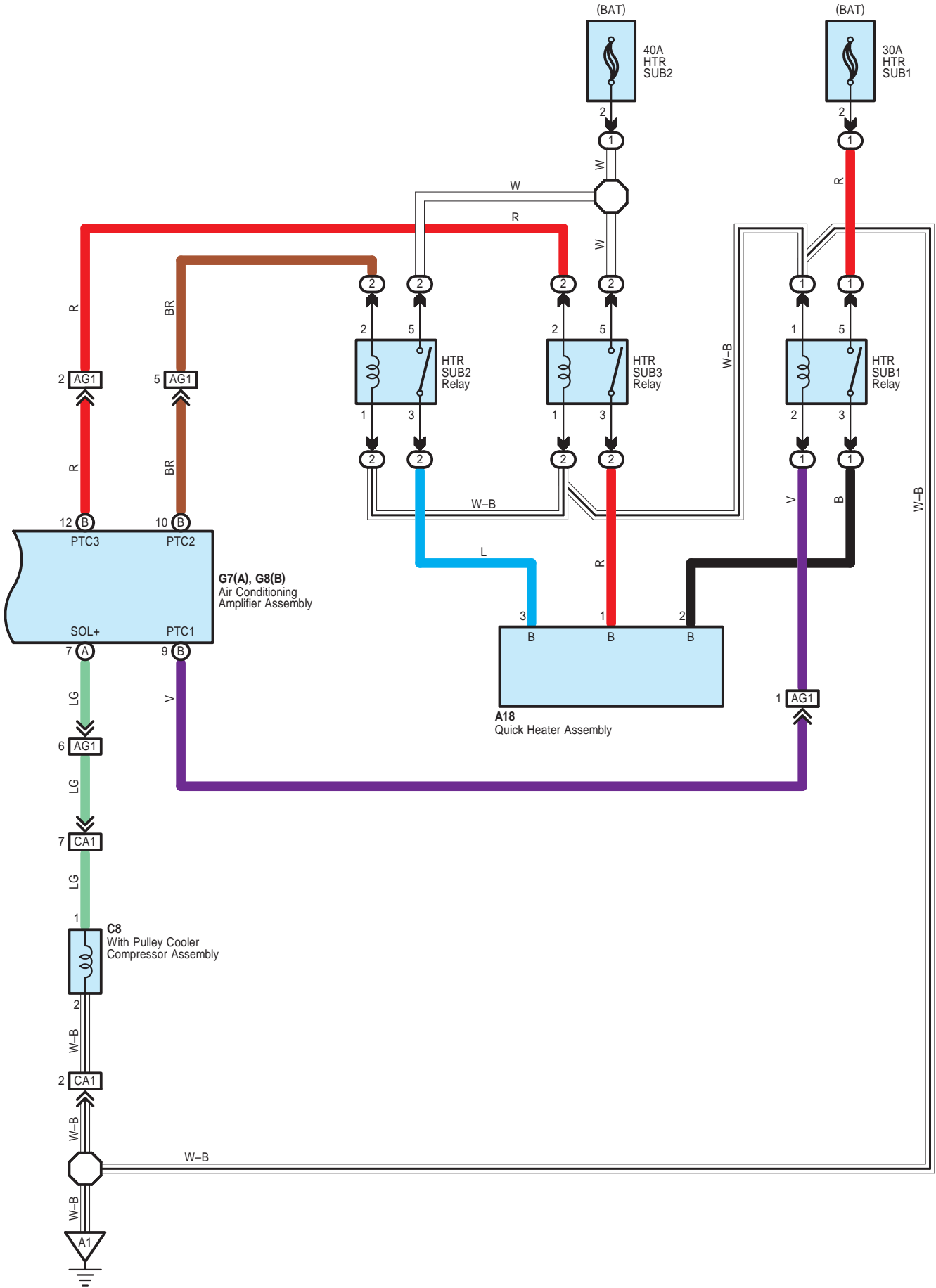

Air Conditioning

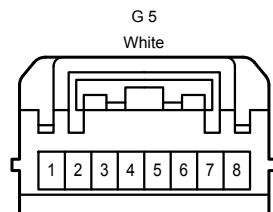
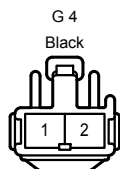
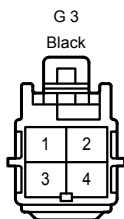
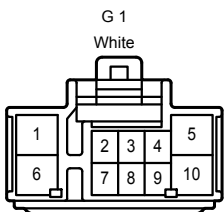
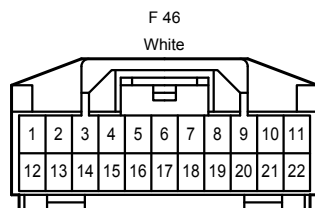
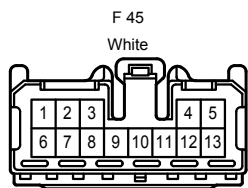
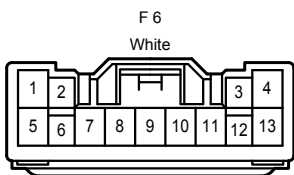
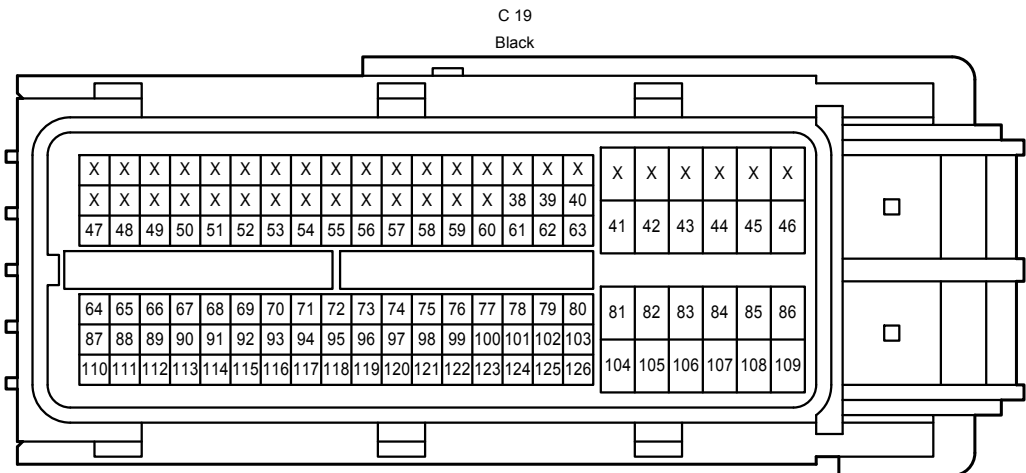
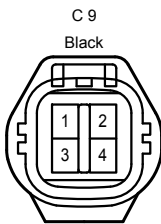
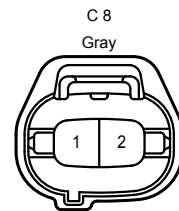
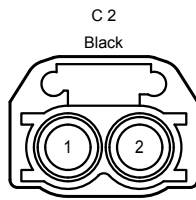
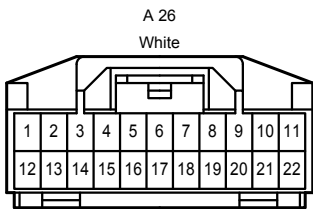
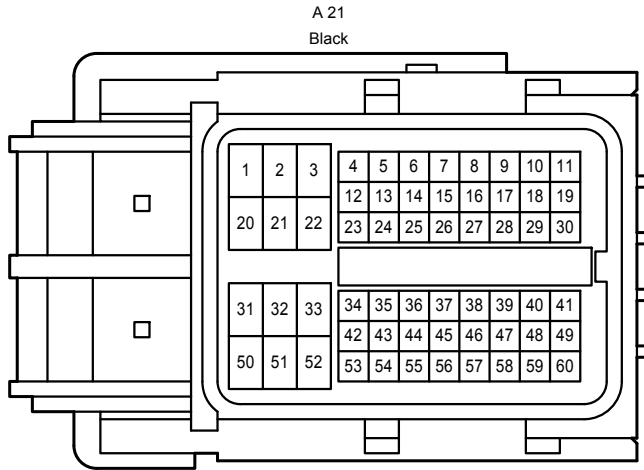
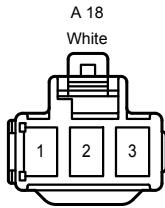
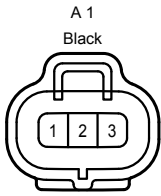

Air Conditioning

G 6

White

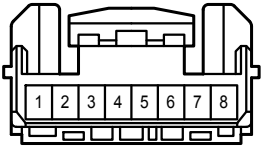

G 7

White

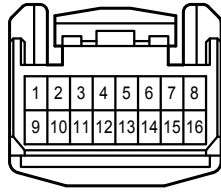

G 8

White

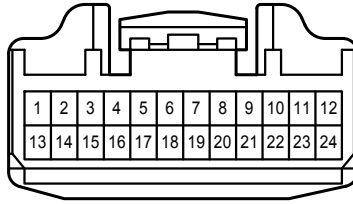

G 9

White

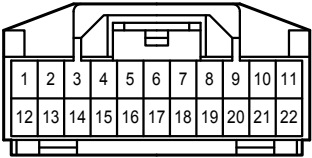

4E

White

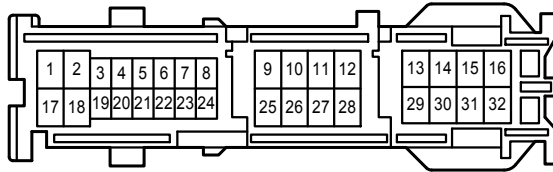

4F

White

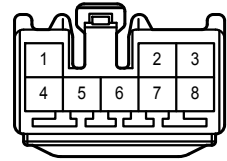

4L

White

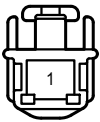

4Q

White

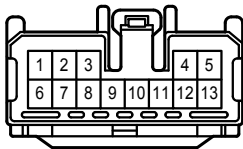

4S

White

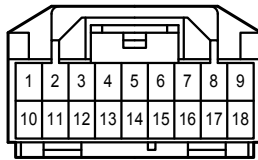

6A

White

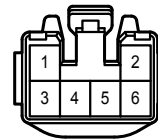

AF4

Gray

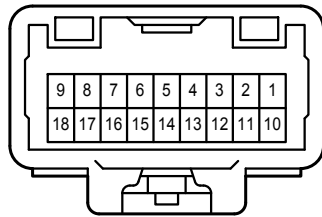
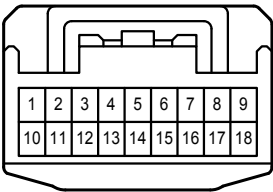

AG1

White

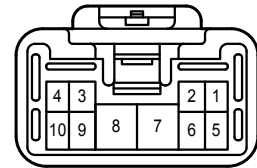
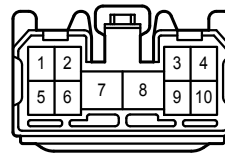

BA1

White

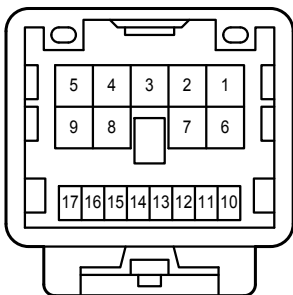
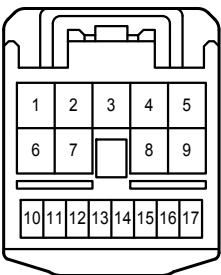

CA1

White

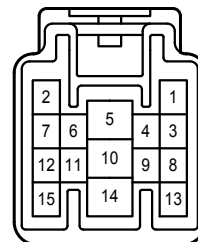
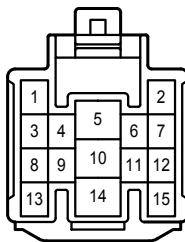

FG1
White

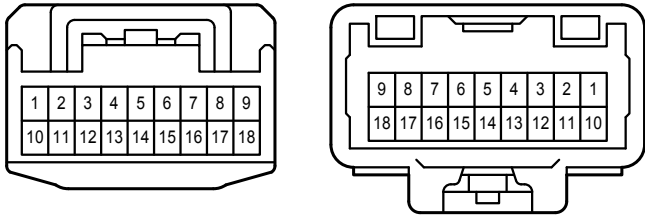

GF1
White

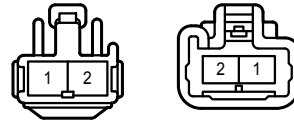

Audio System

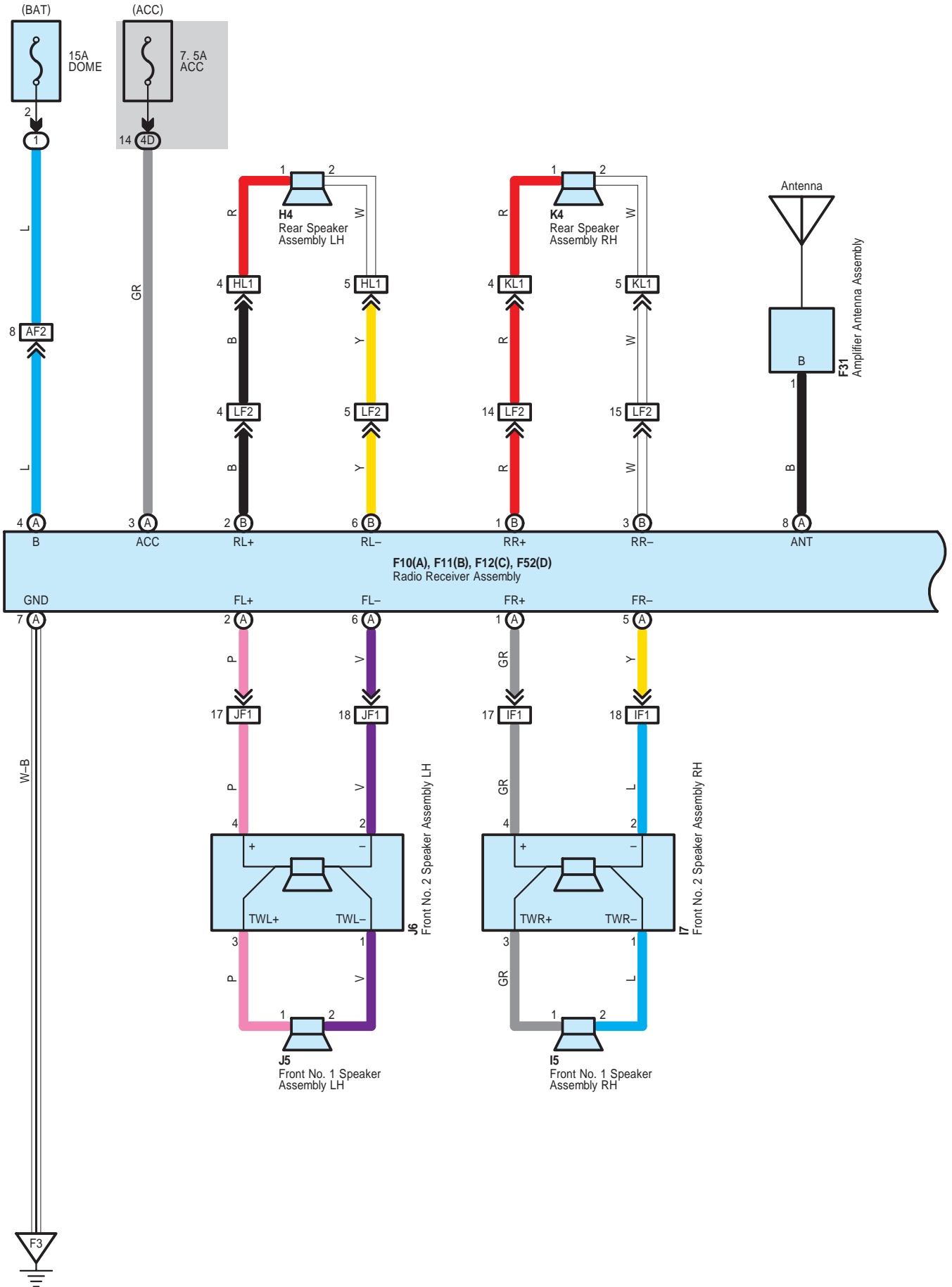

: There is no wire color information.

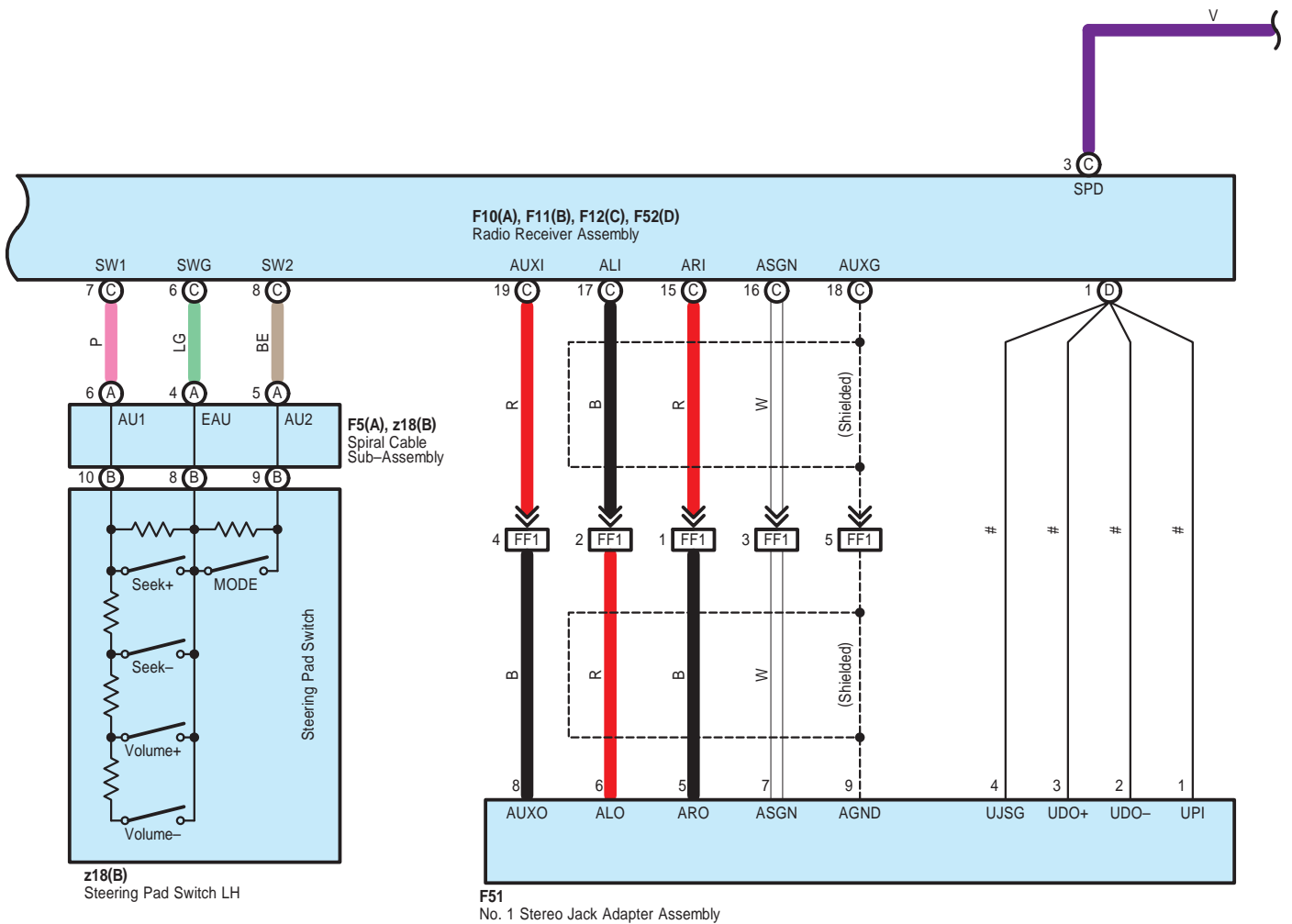

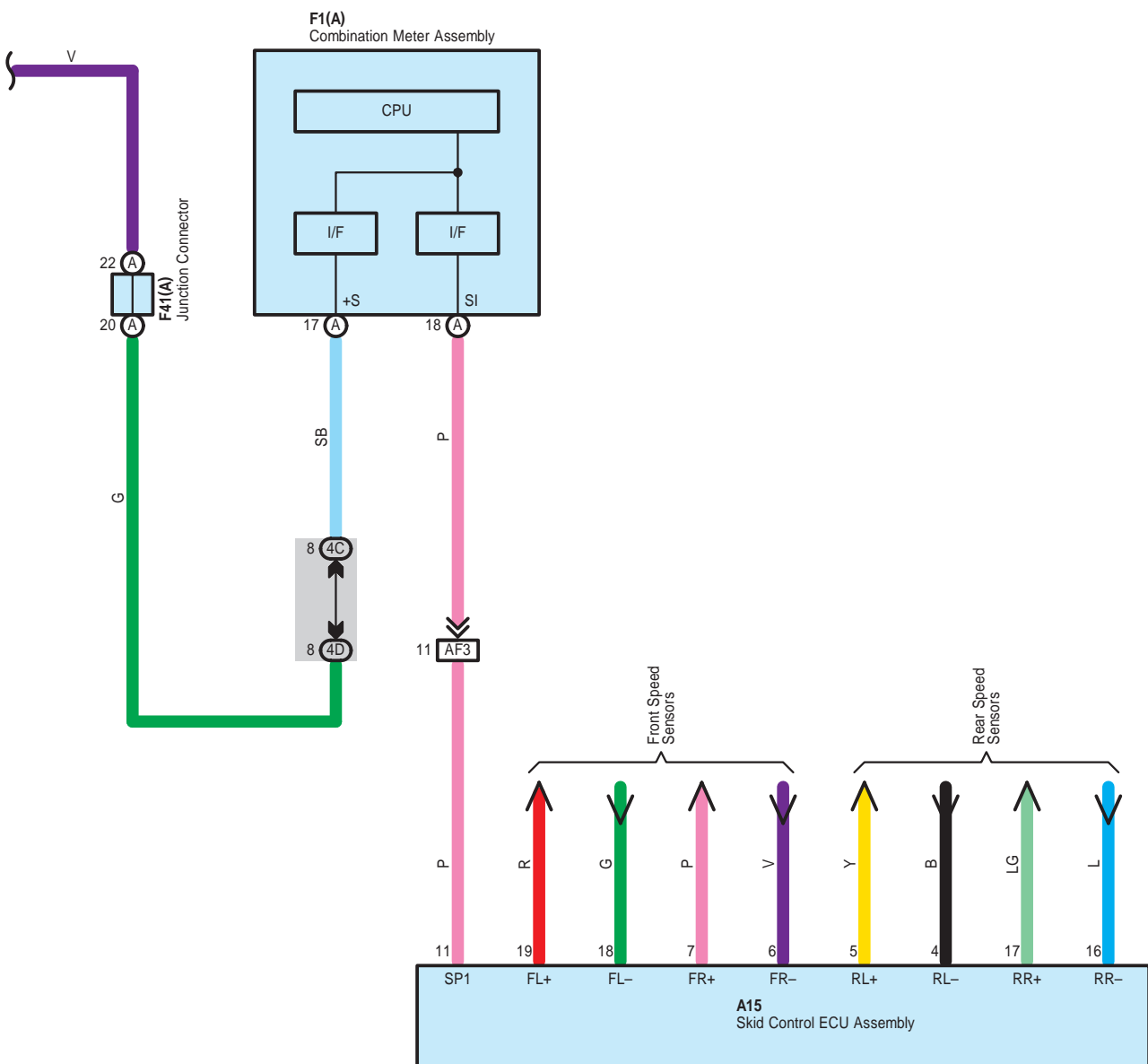

Audio System

A 15
Black

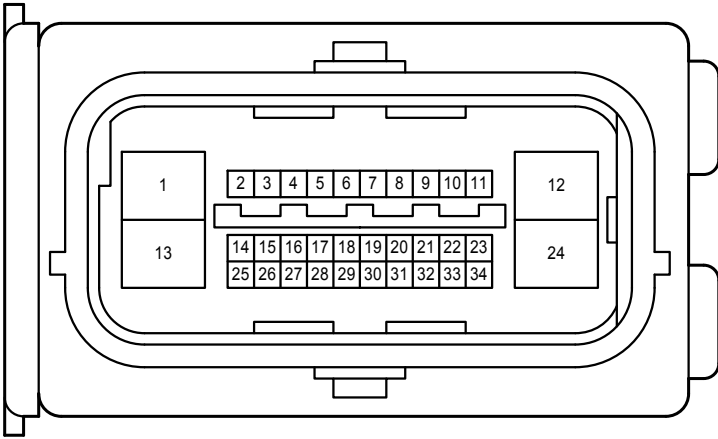

F 1
White

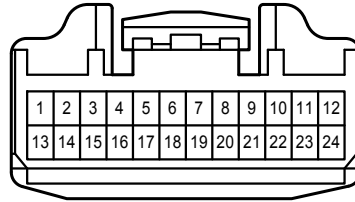

F 5
White



F 10
Blue

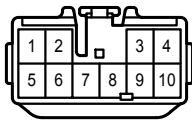

F 11
White

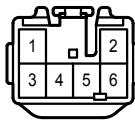

F 12
White

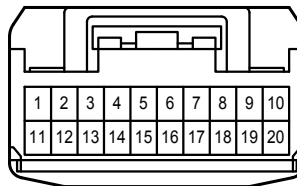

F 31
White



F 41
White

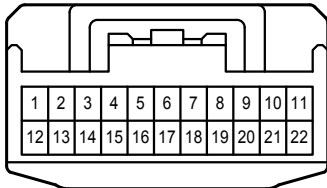

F 51
Gray

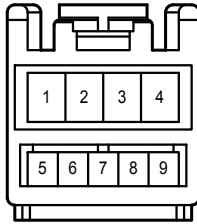

F 52
Gray



H 4
White



I 5
White



I 7
White

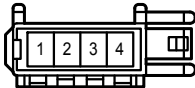

J 5
White



J 6
White

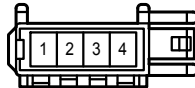

K 4
White



z 18
White

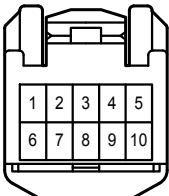

4C
White

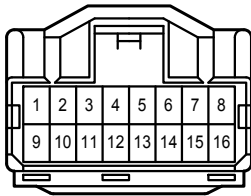

4D
White

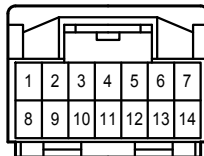

Audio System

AF2
White

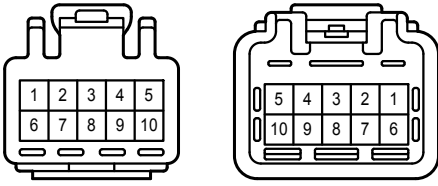

AF3
Black

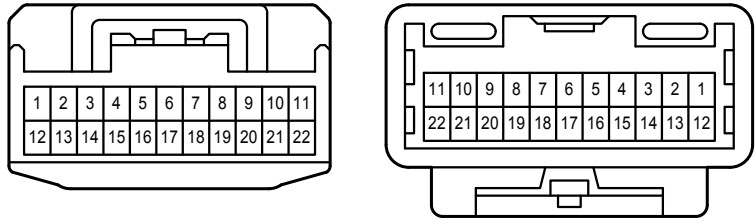

FF1
White

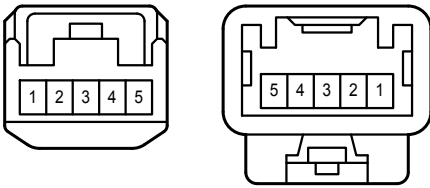

HL1
White

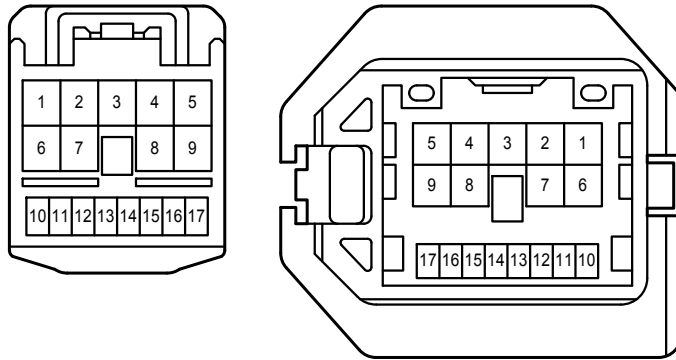

IF1
White

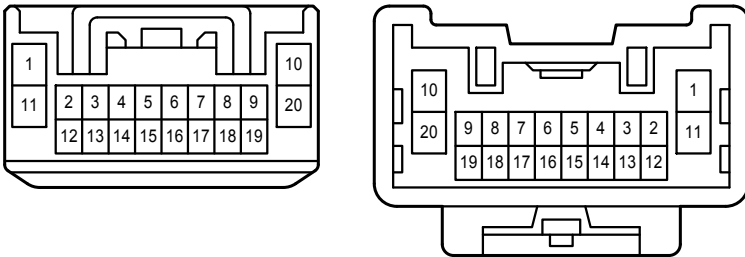

JF1
White

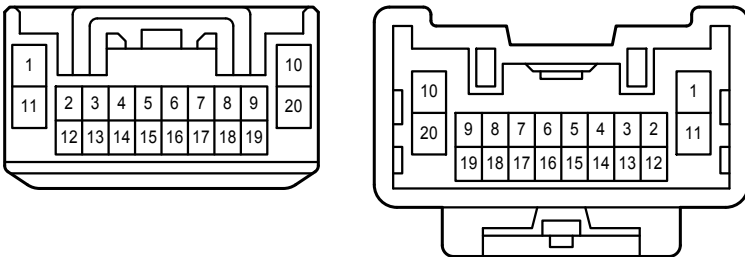

KL1
White

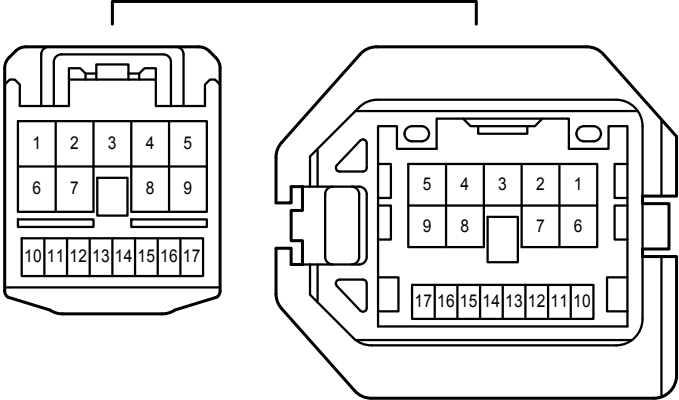

LF2
White

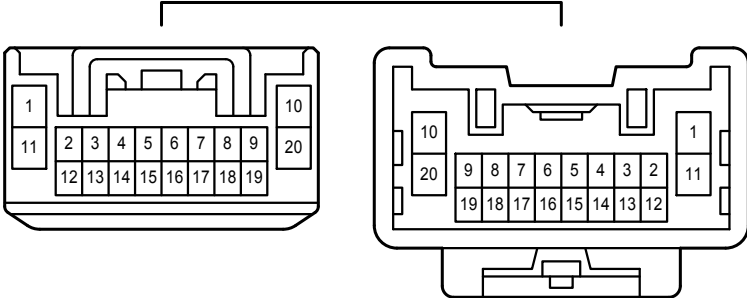

Back Door Opener

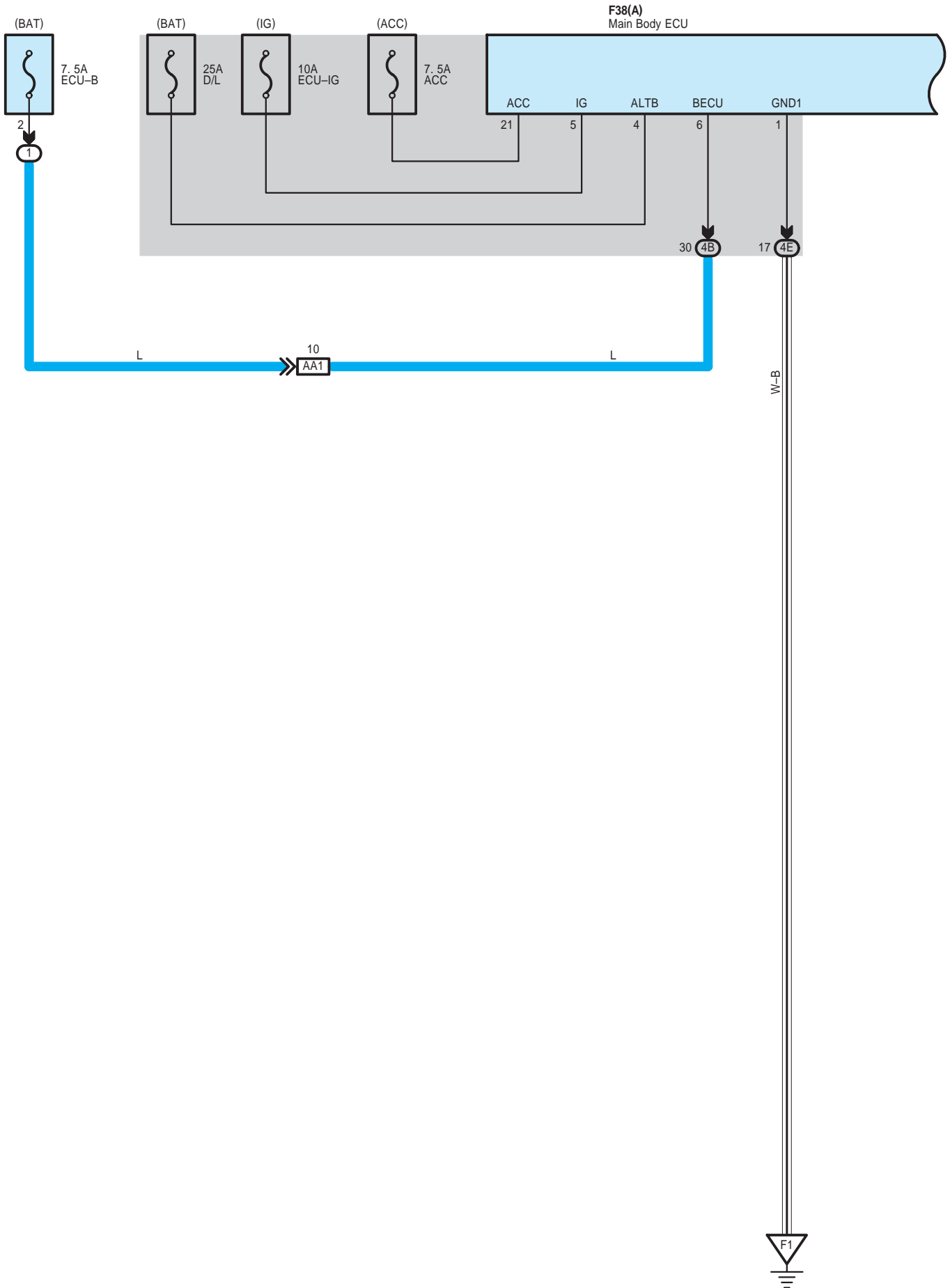

Back Door Opener

F38(A)
Main Body ECU

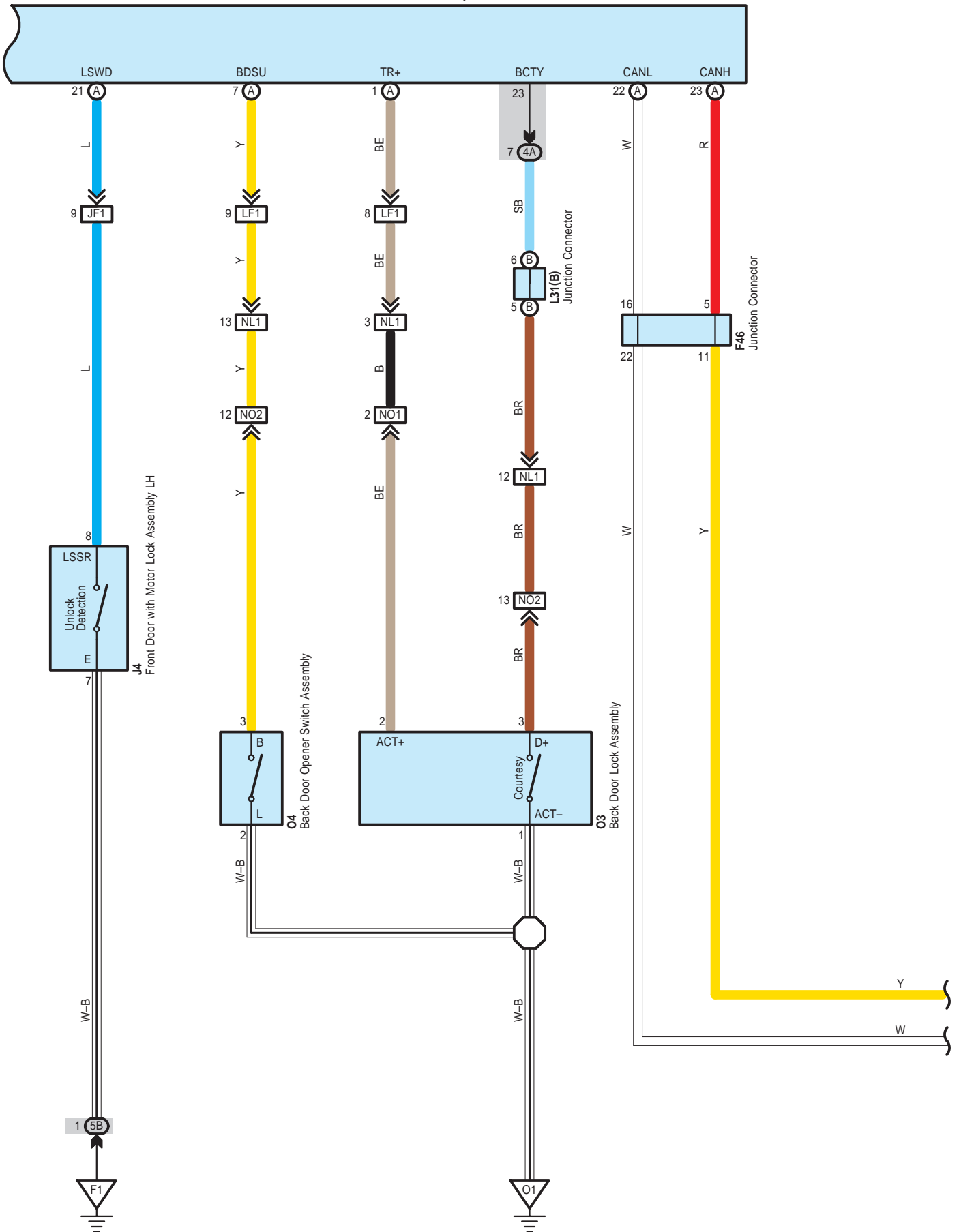

Back Door Opener

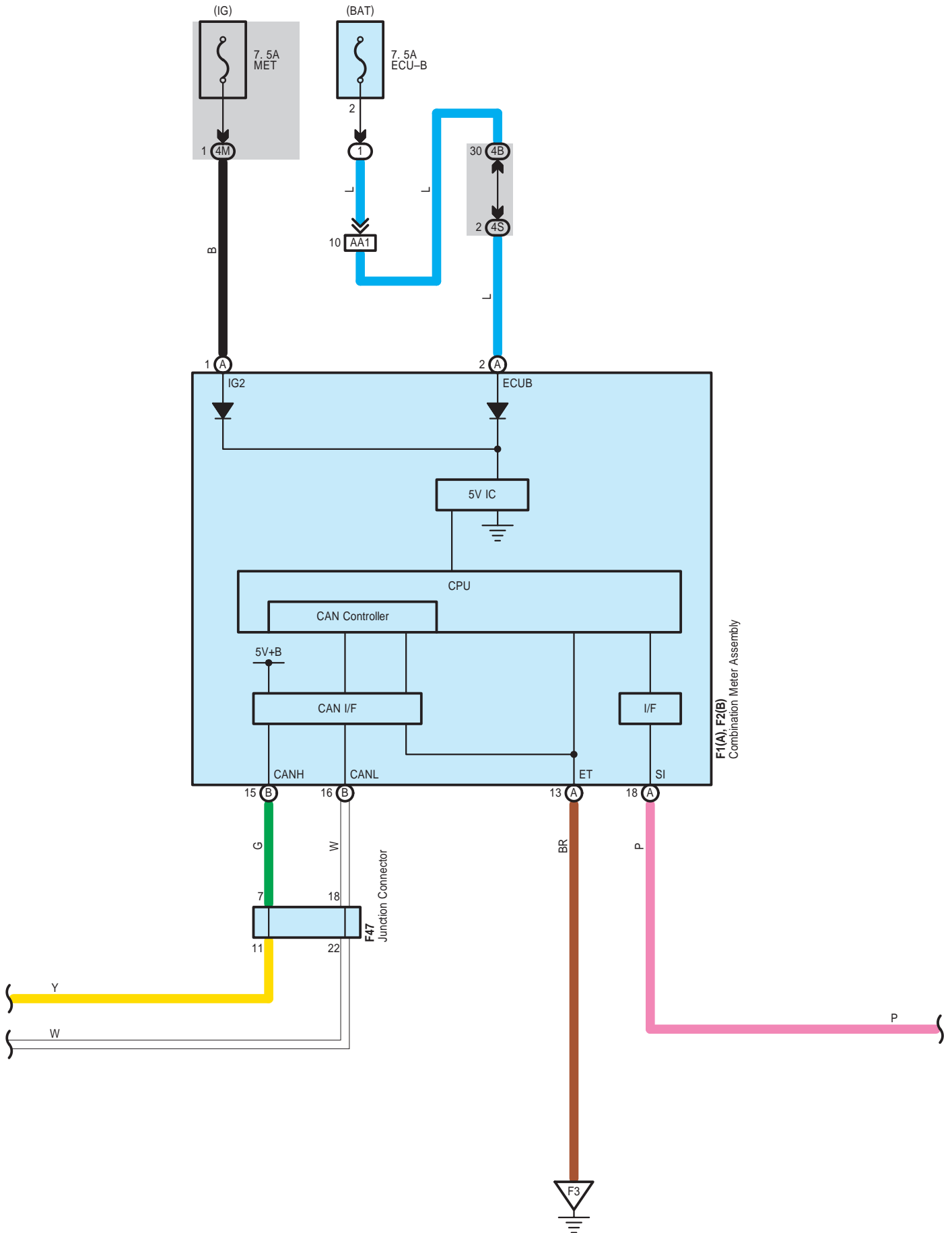

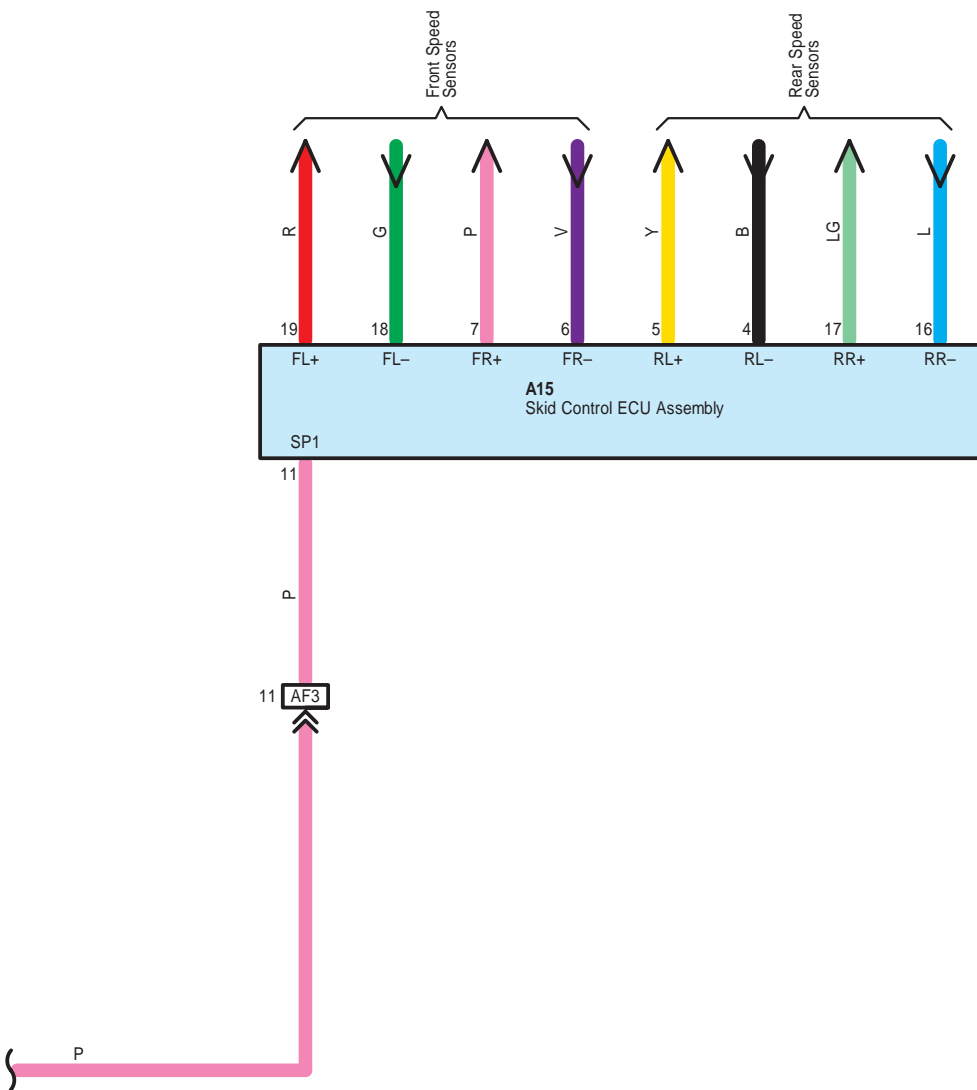

Back Door Opener

A 15
Black

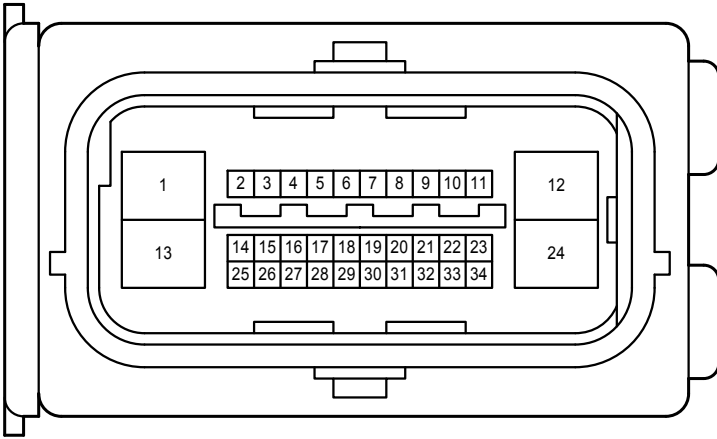

F 1
White

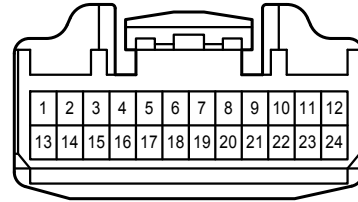

F 2
White

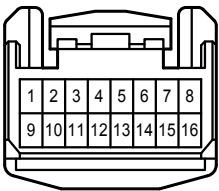

F 38
White

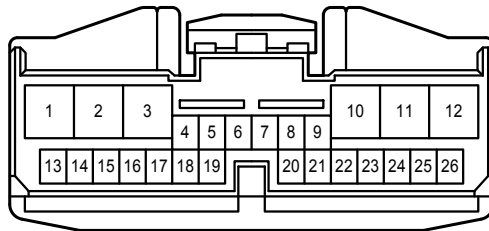

F 46
White

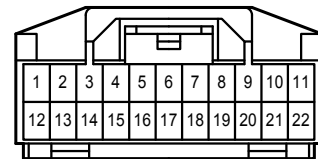

F 47
White

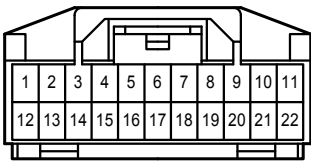

J 4
White



L 31
White

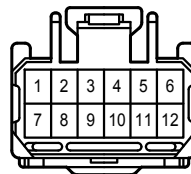

O 3
Black

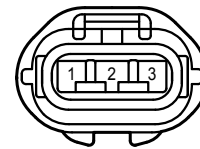

O 4
White

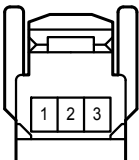

4B
White

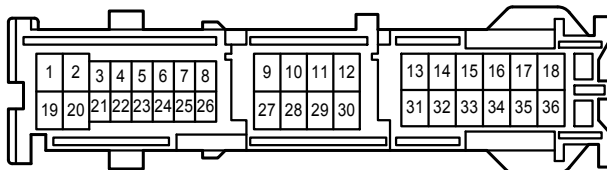

4E
White

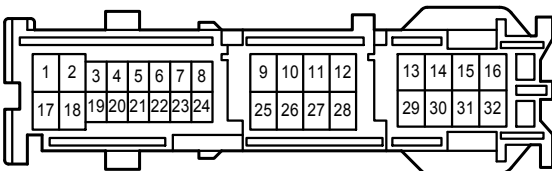

4M
White

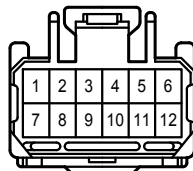

4S
White

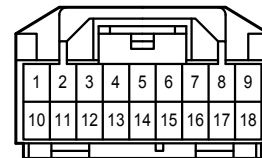

Back Door Opener

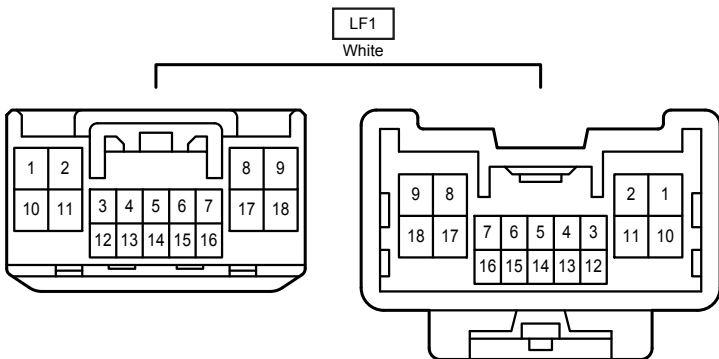
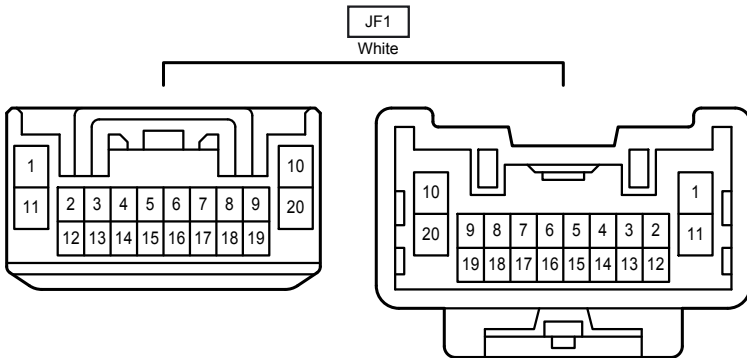
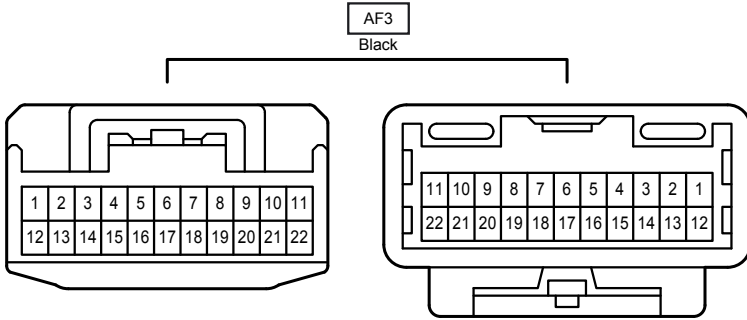
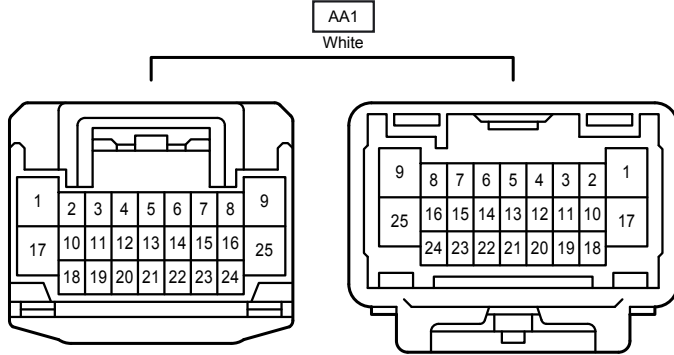
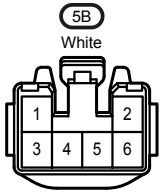

Back Door Opener

NL1
White

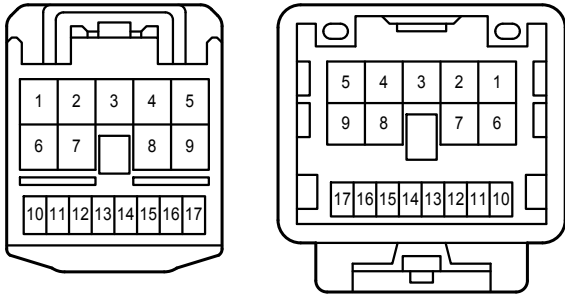

NO1
White

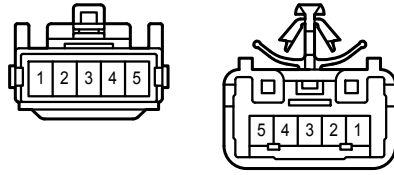

NO2
White

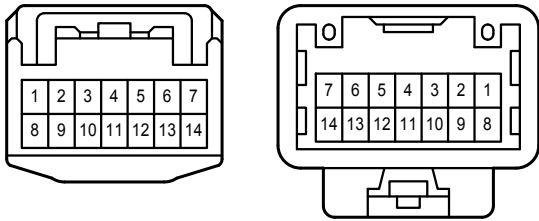

Back-Up Light

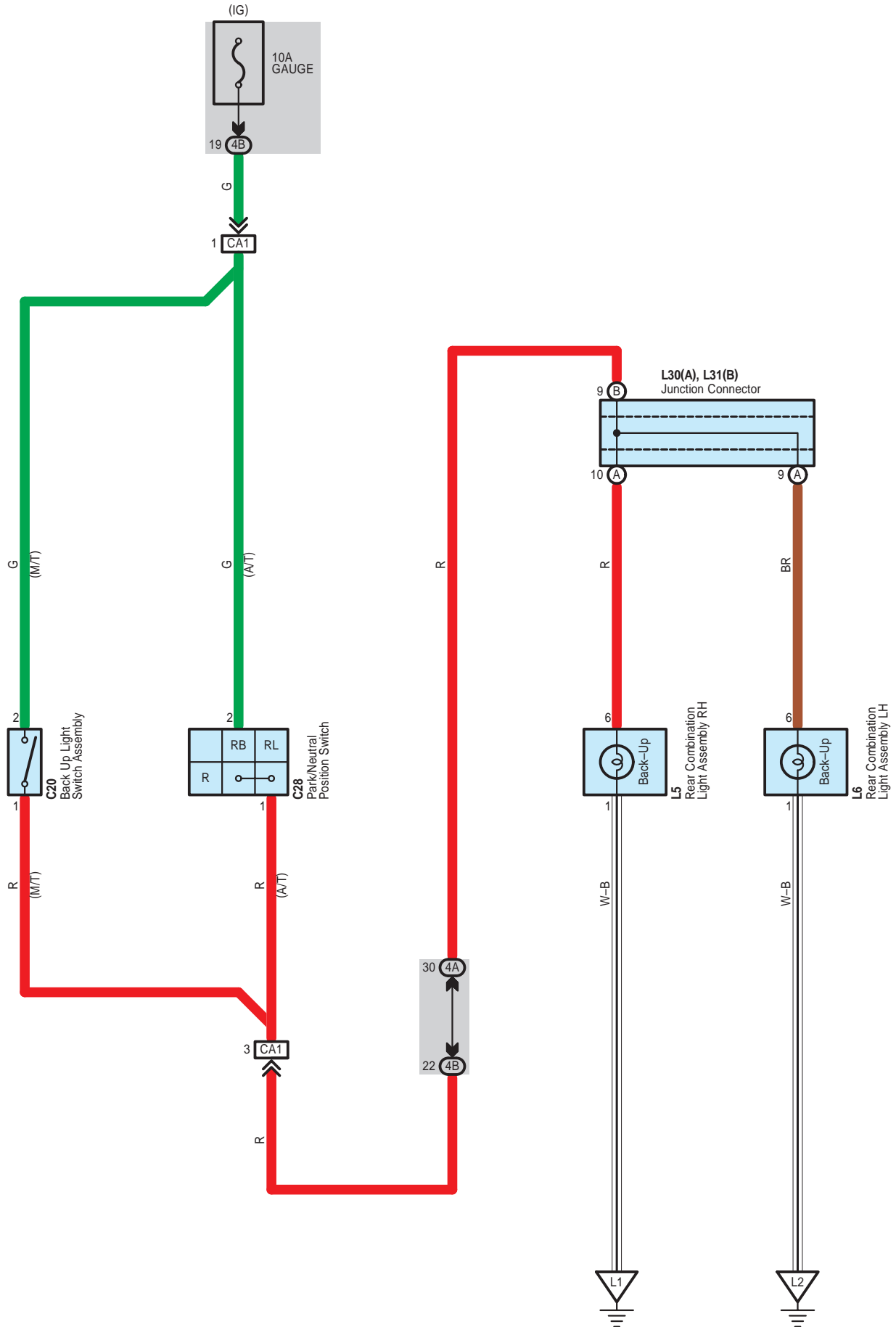

Back-Up Light

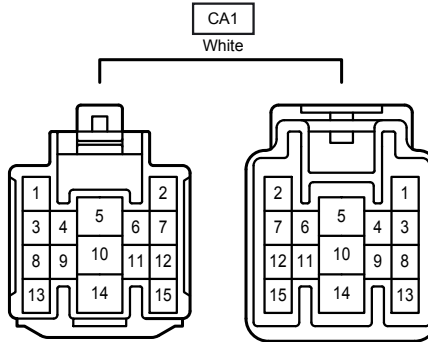
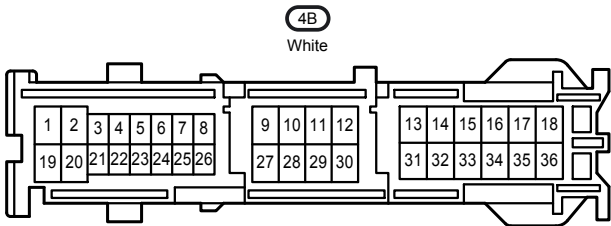
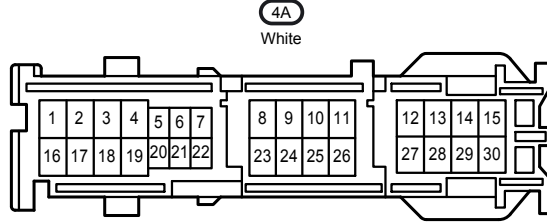
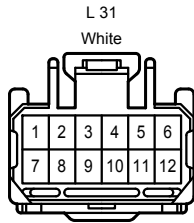
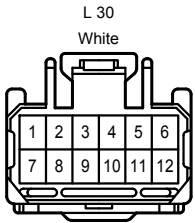
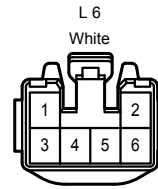
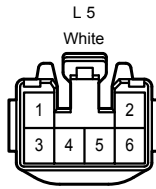
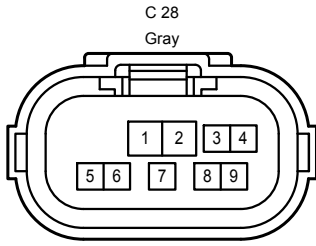
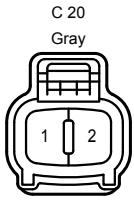

Charging

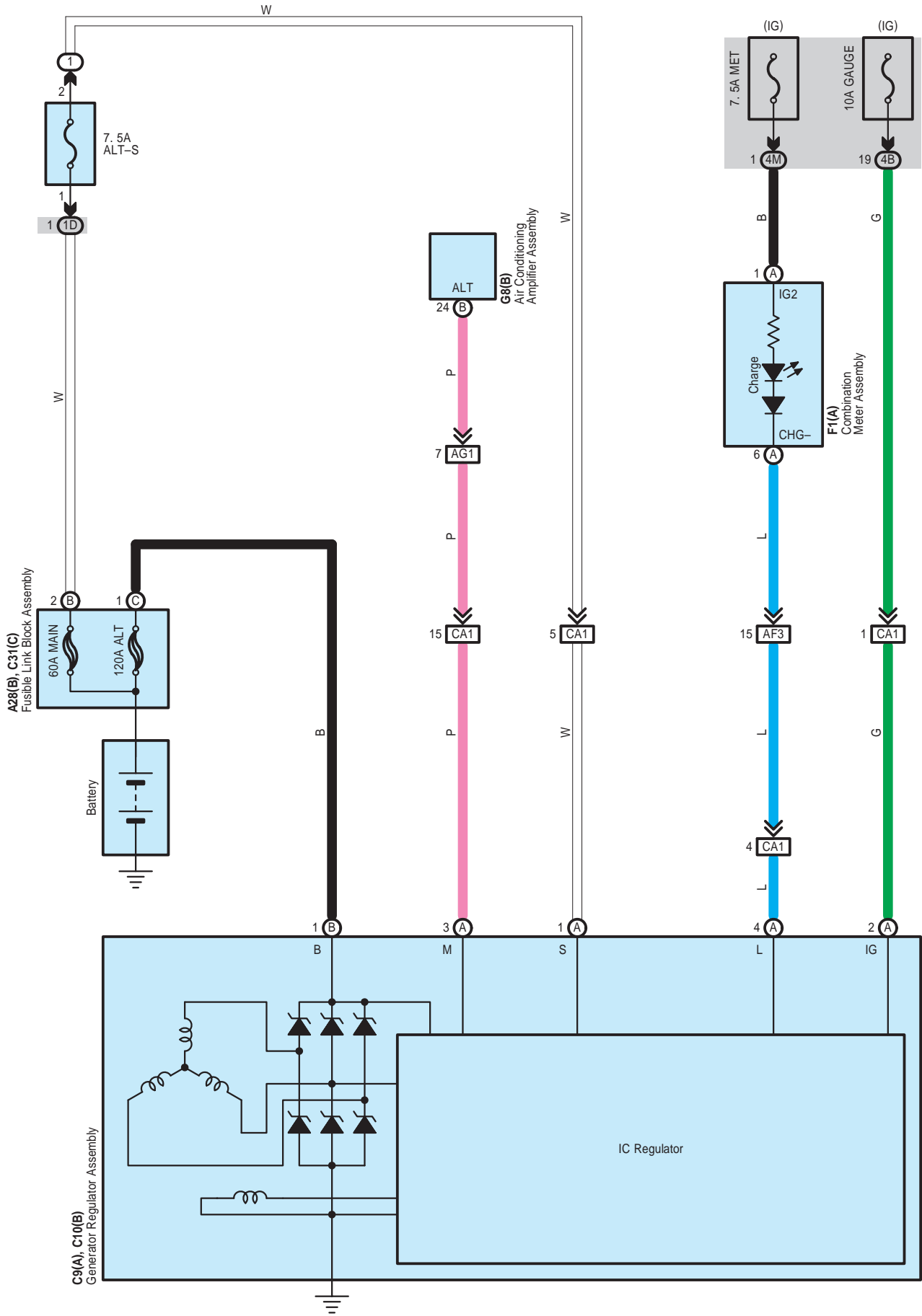

Charging

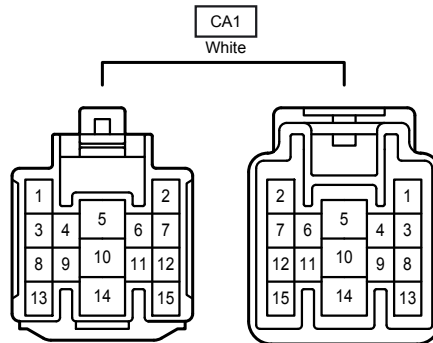
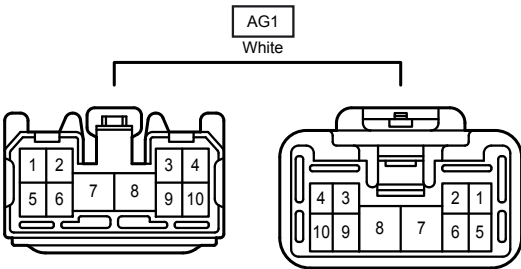
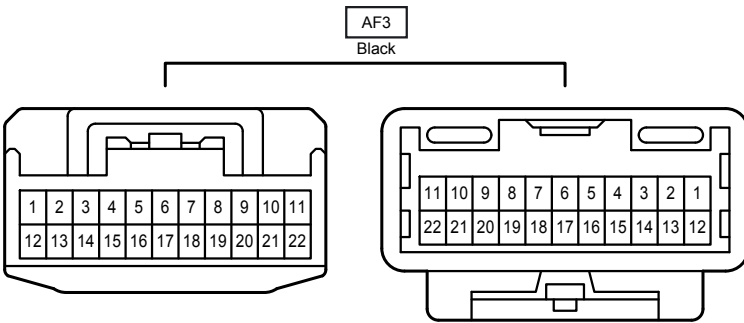
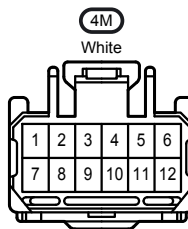
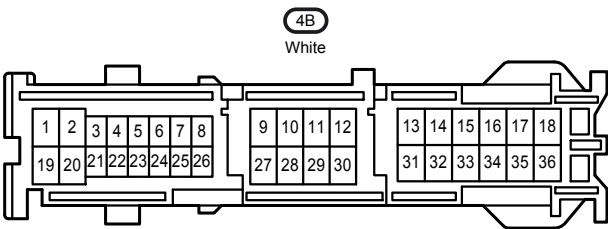
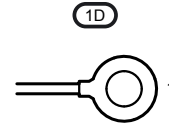
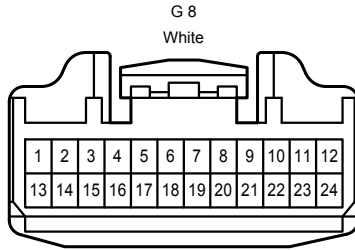
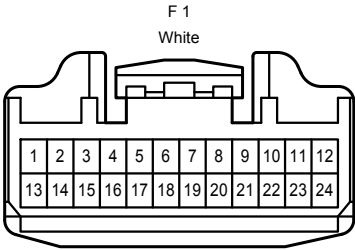
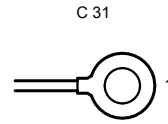
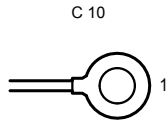
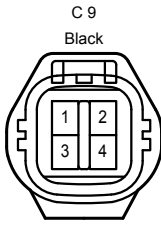
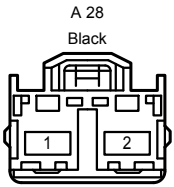

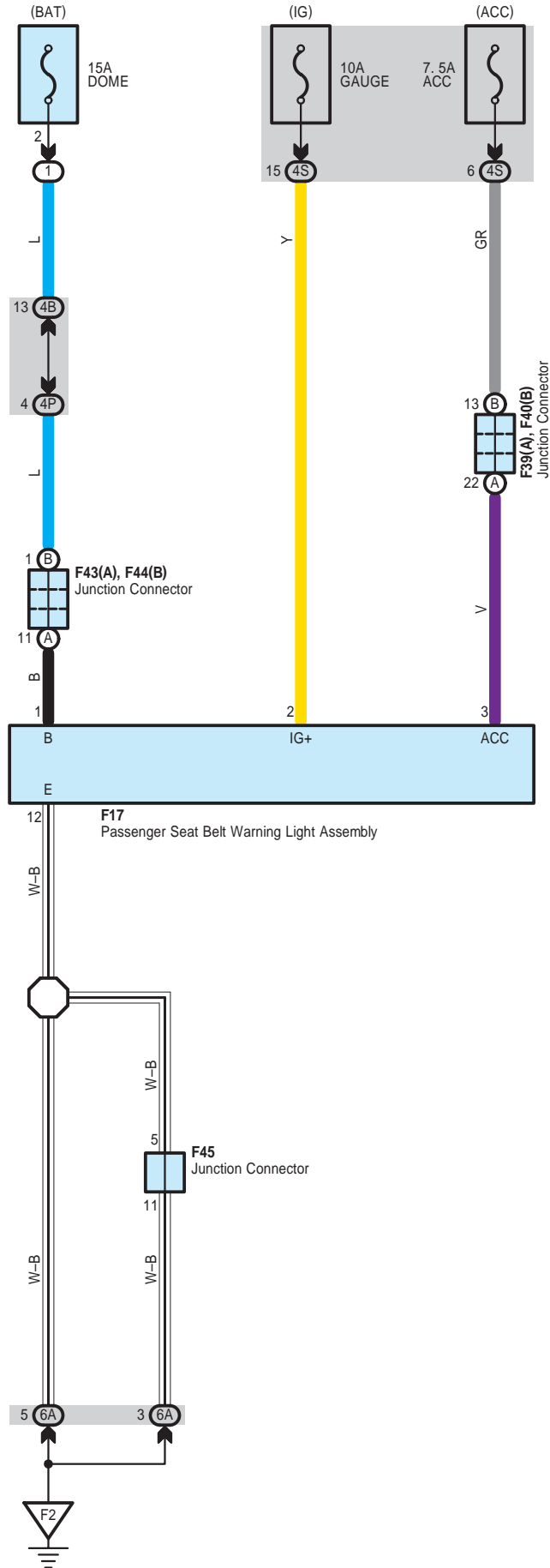

Clock

F 17
White

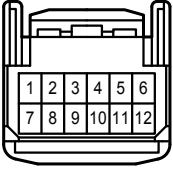

F 39
White

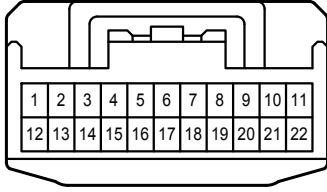

F 40
White

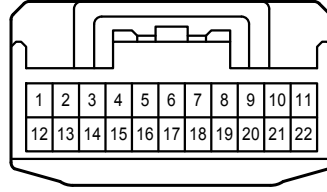

F 43
White

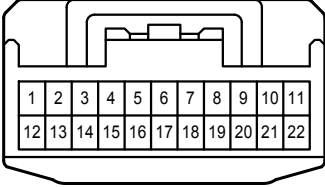

F 44
White

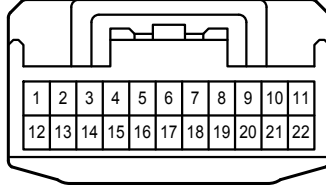

F 45
White

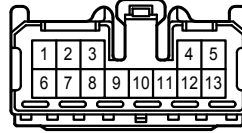

4B
White

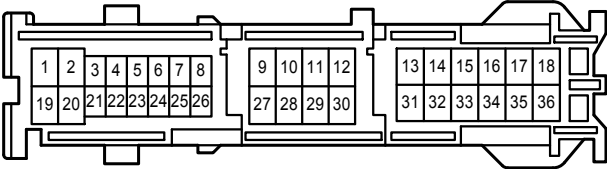

4P
White

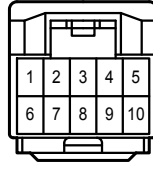

4S
White

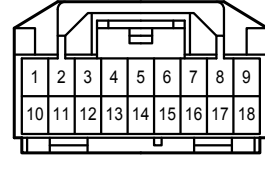

6A
White



Combination Meter

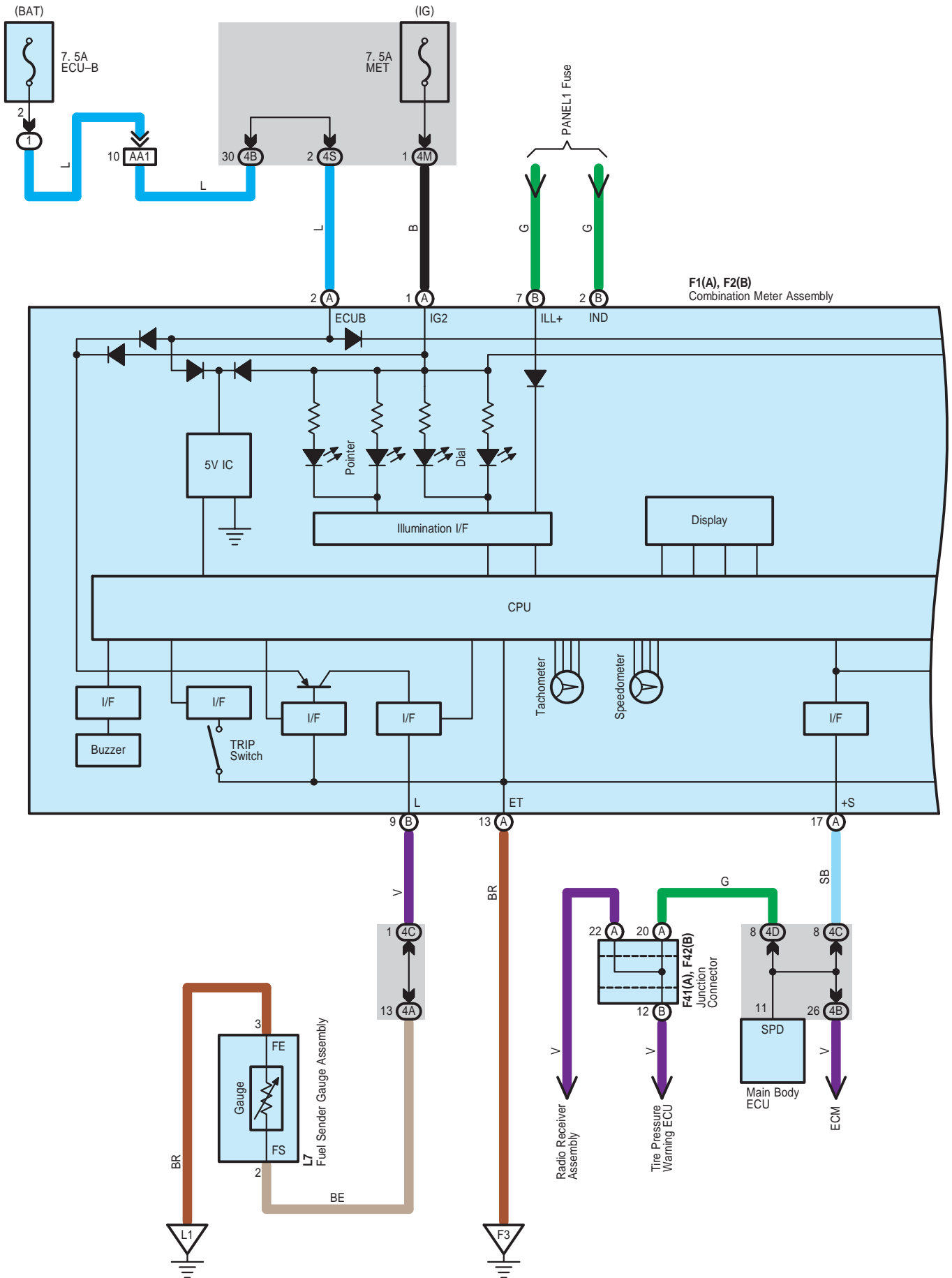

Combination Meter

F1(A), F2(B)
Combination Meter Assembly

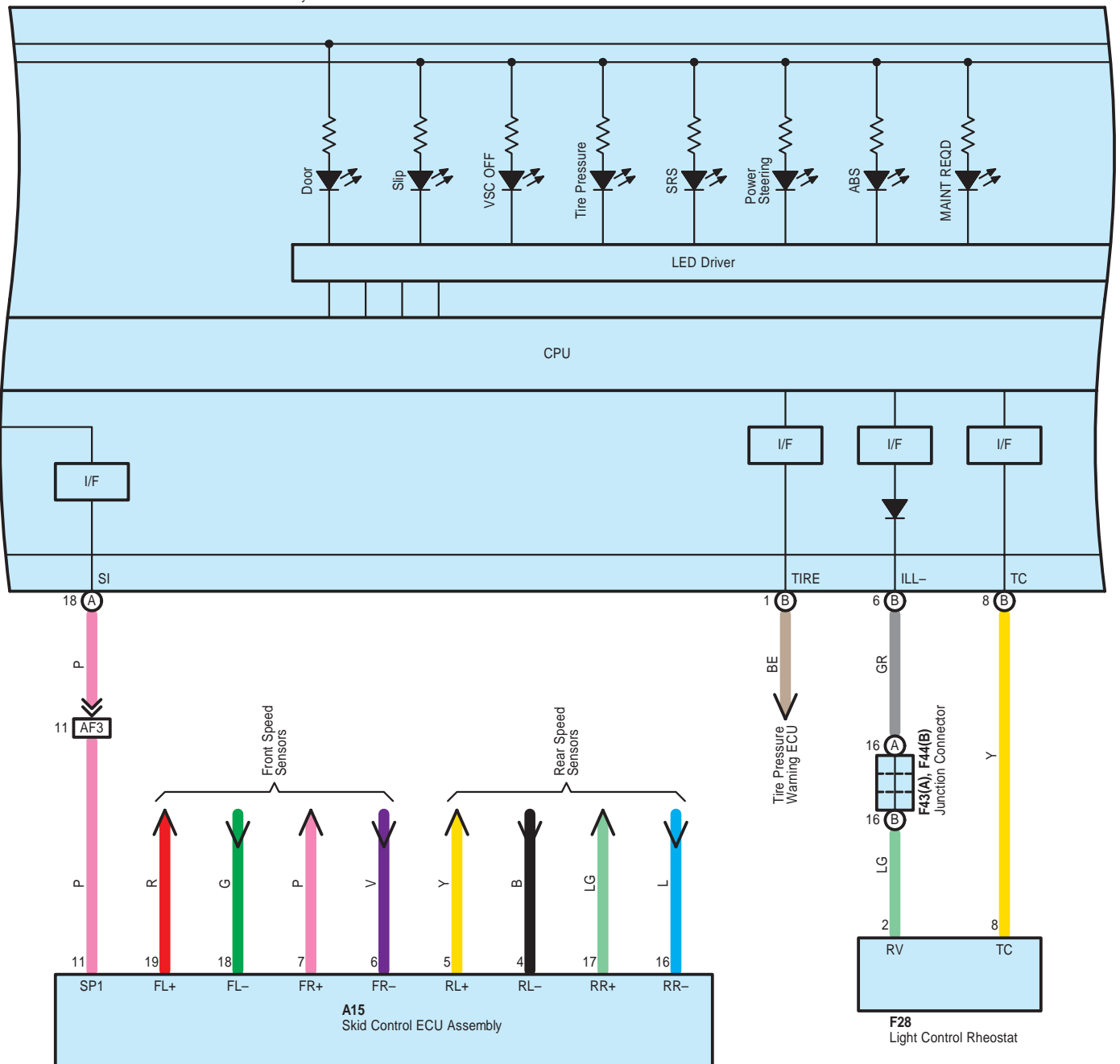

F1(A), F2(B)
Combination Meter Assembly

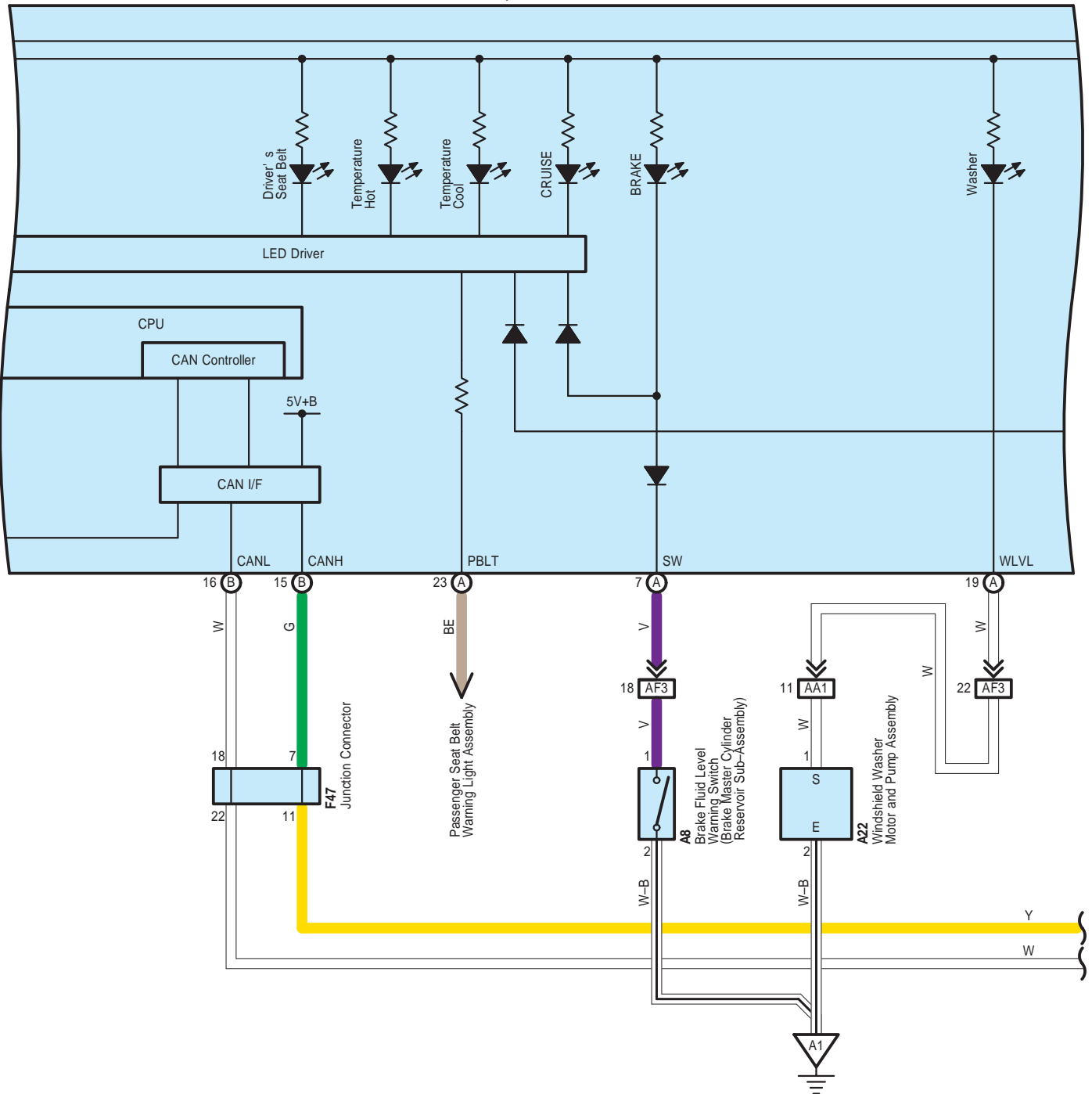

Combination Meter

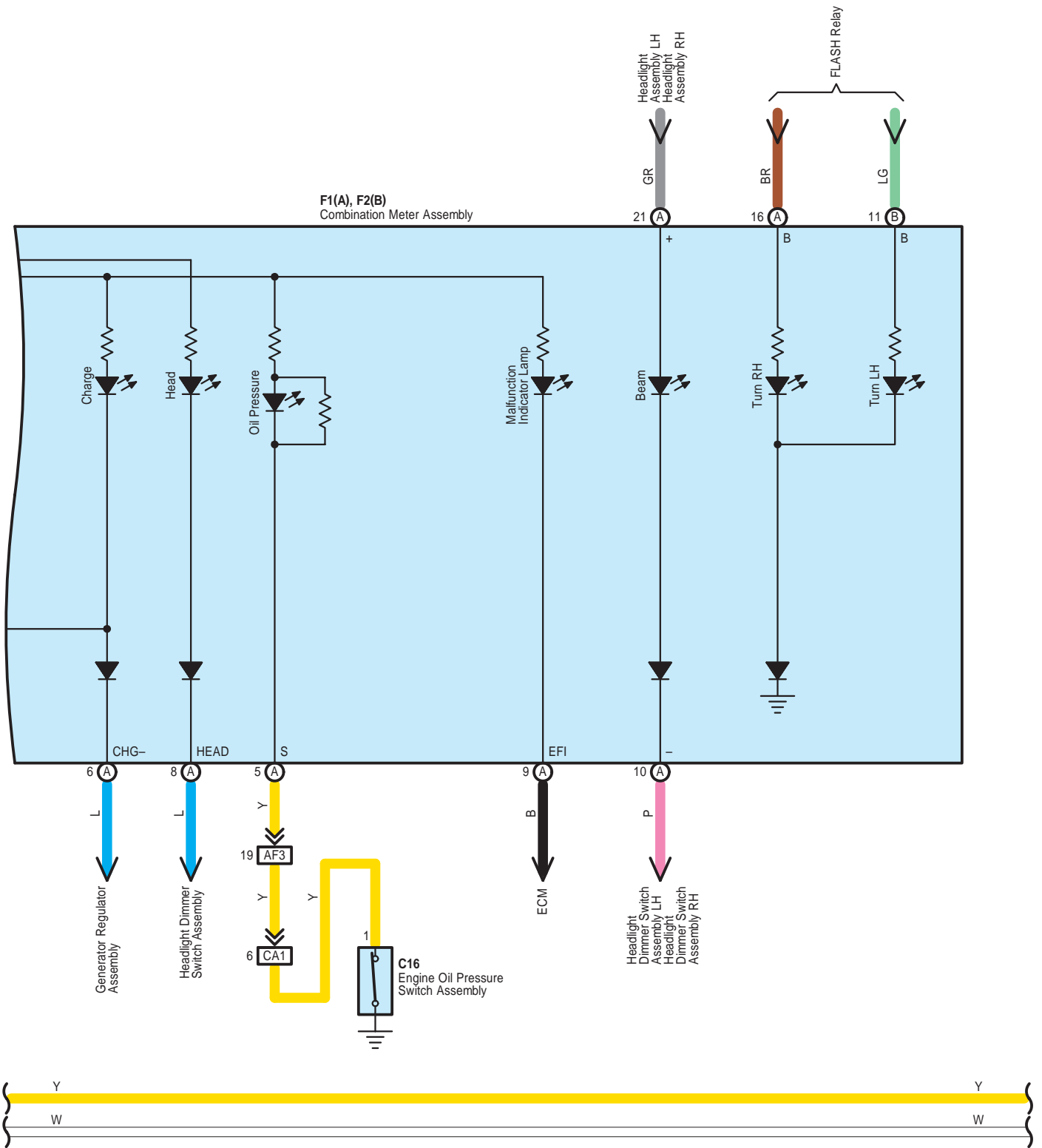

Combination Meter

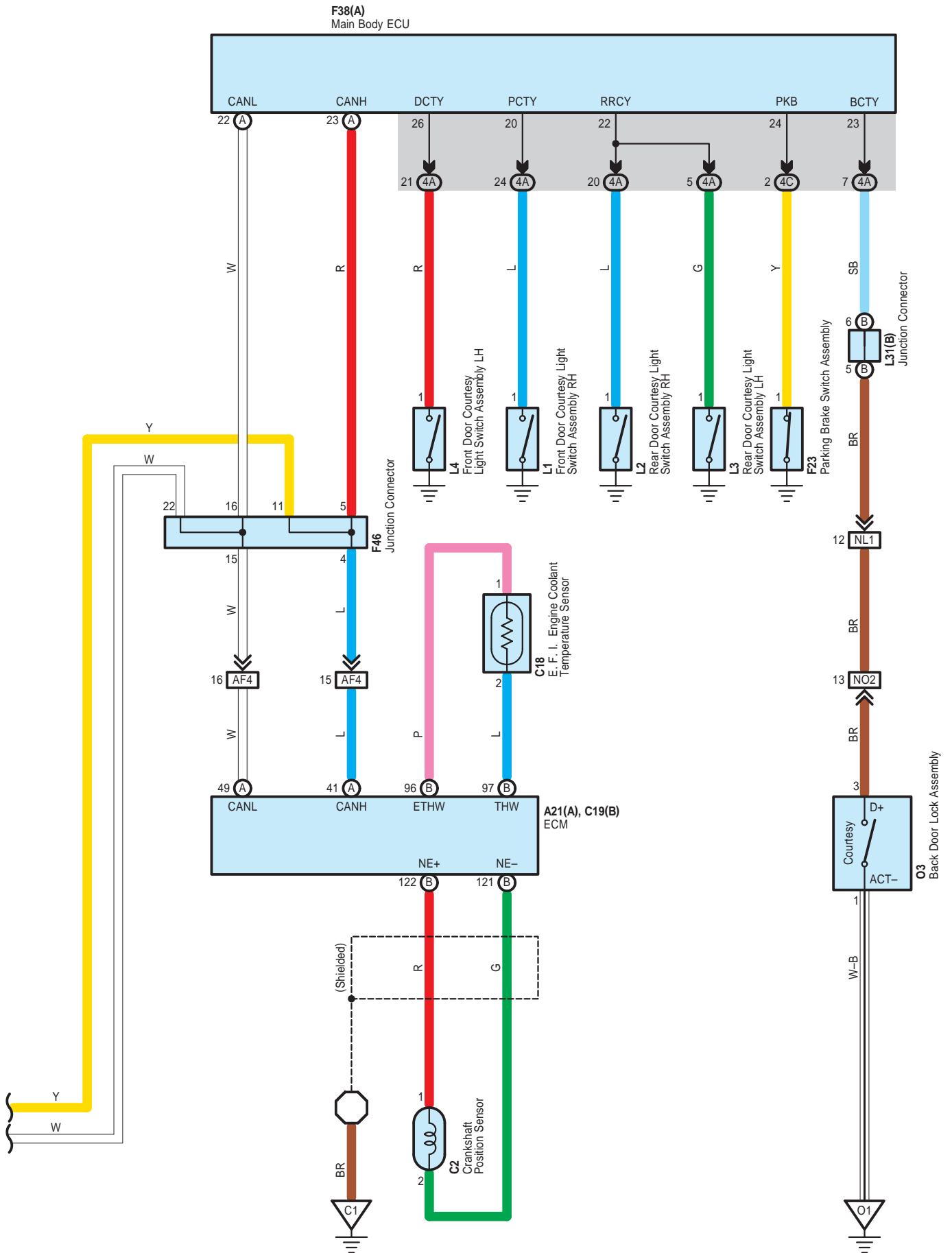

Combination Meter

F 1
White

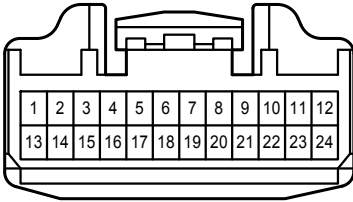

F 2
White

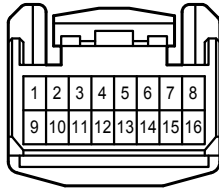

F 23
White



F 28
White

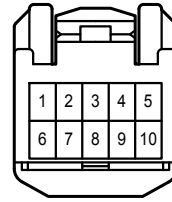

F 38
White

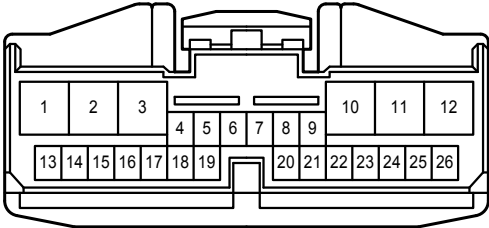

F 41
White

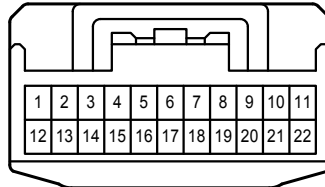

F 42
White

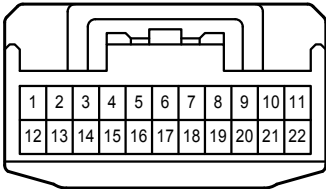

F 43
White

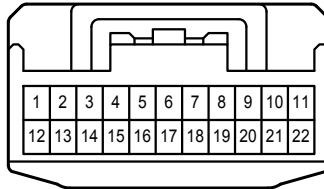

F 44
White

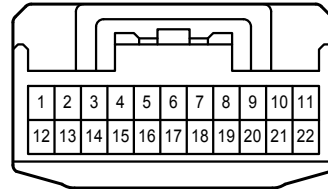

F 46
White

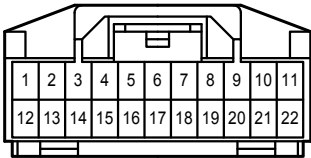

F 47
White

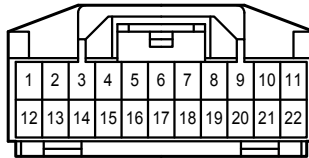

L 1
White



L 2
White



L 3
White



L 4
White



L 7
White



L 31
White

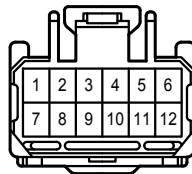

O 3
Black

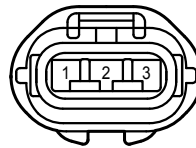

4A
White

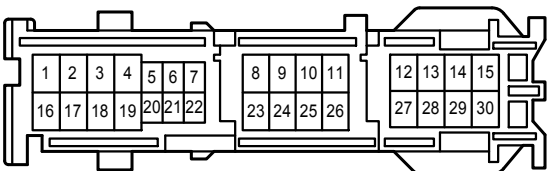

4B
White

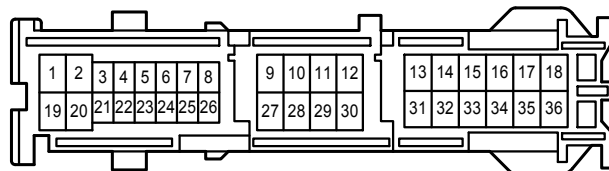

Combination Meter

4C

White

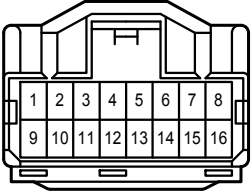

4D

White

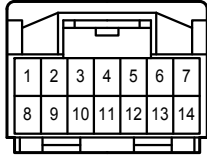

4M

White

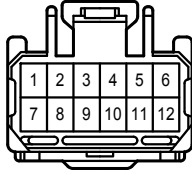

4S

White

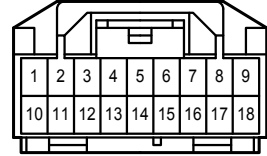

AA1

White

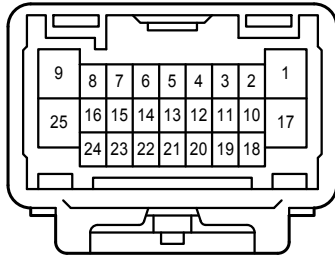
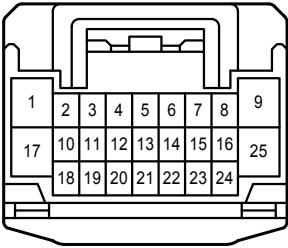

AF3

Black

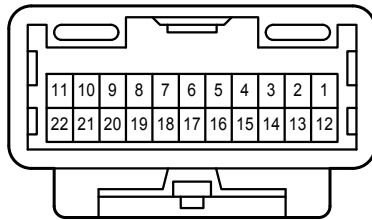
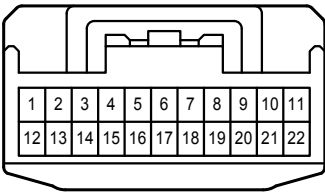

AF4

Gray

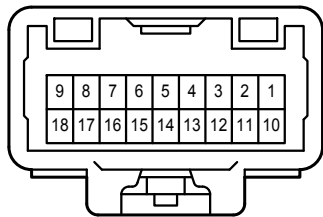
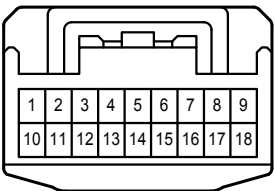

CA1

White

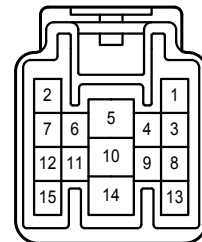
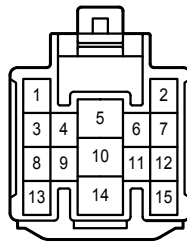

NL1

White

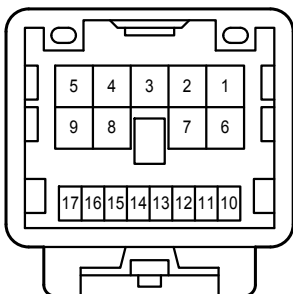
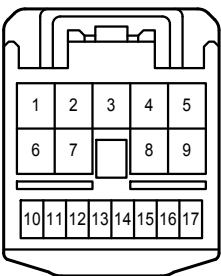

NO2

White

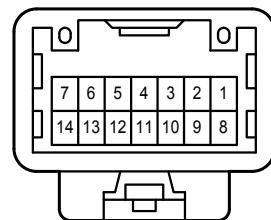
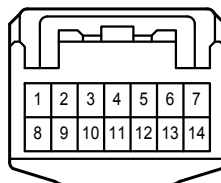

Cooling Fan

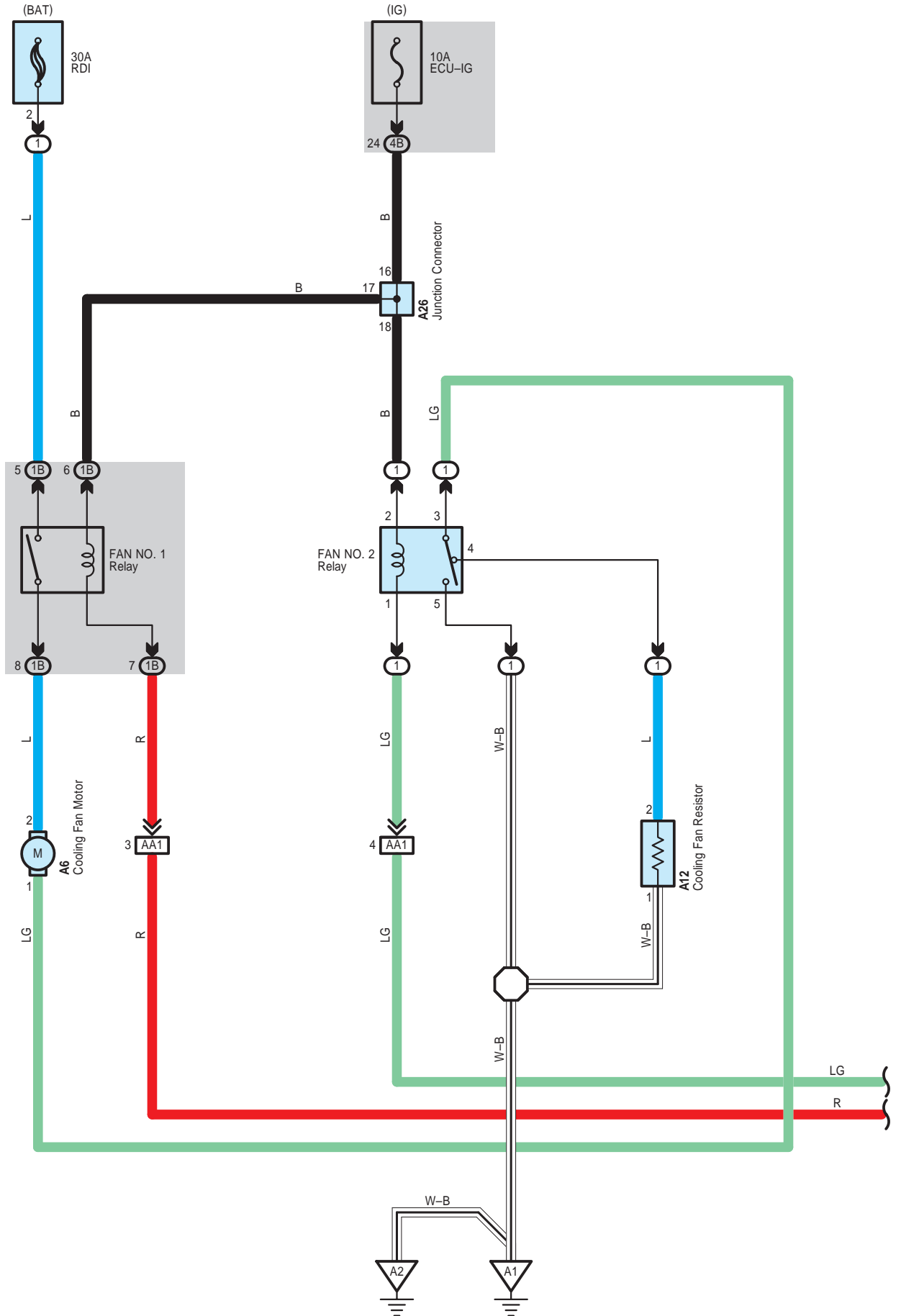

Cooling Fan

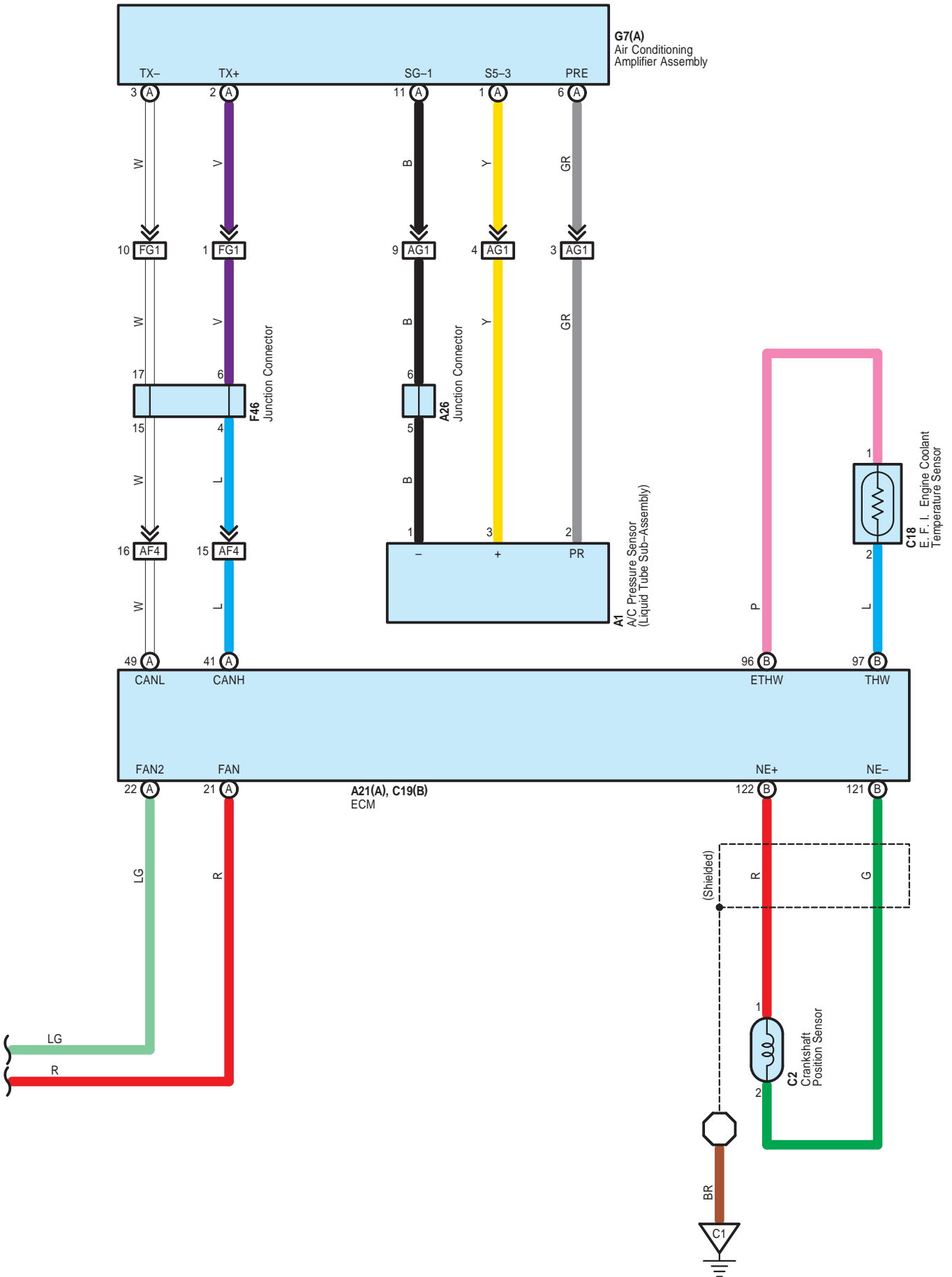

Cooling Fan

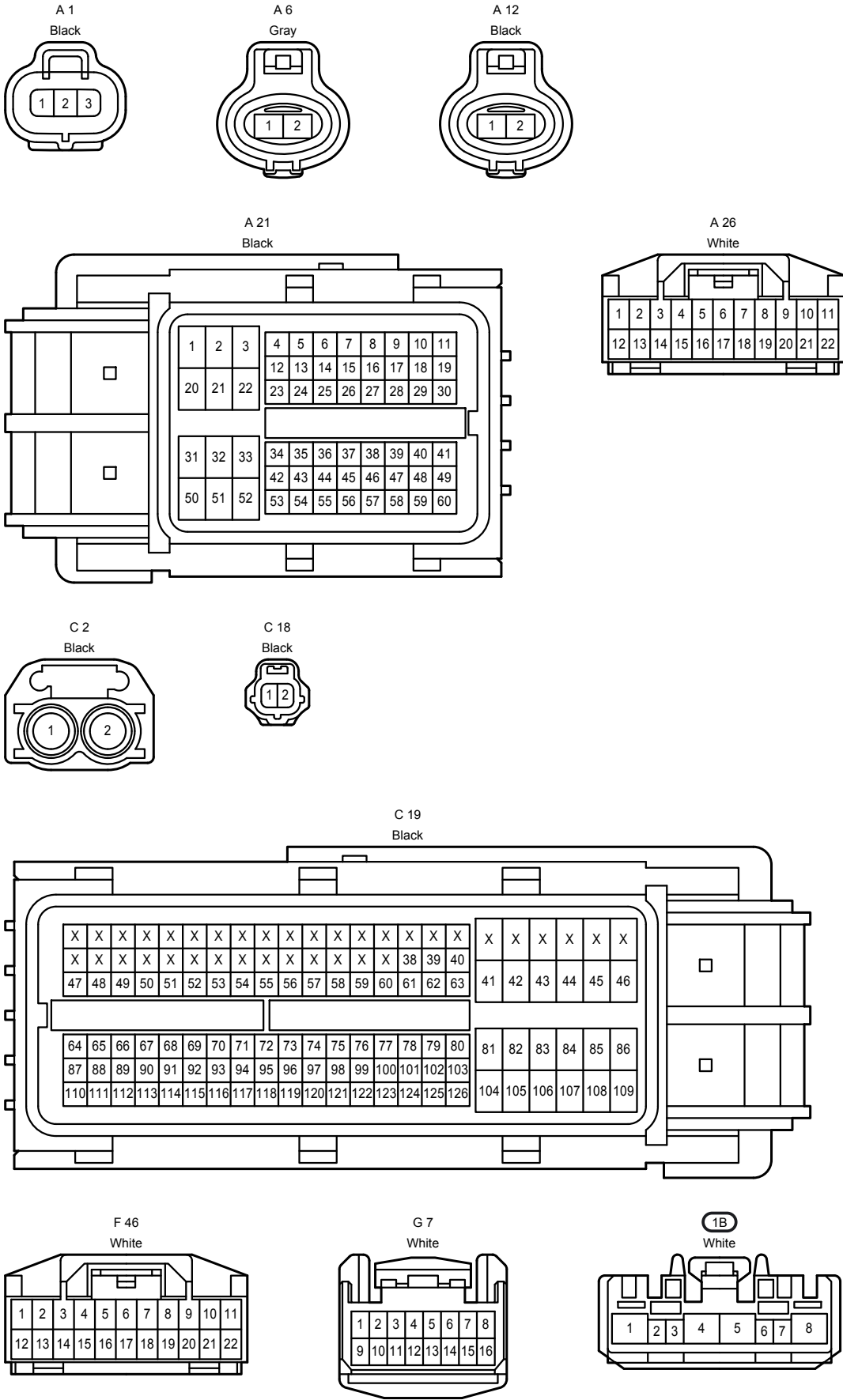

4B
White

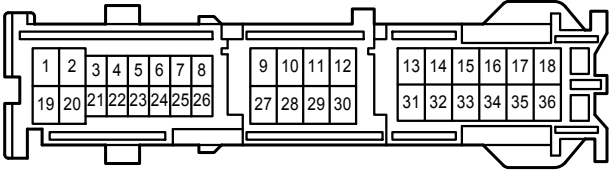

AA1
White

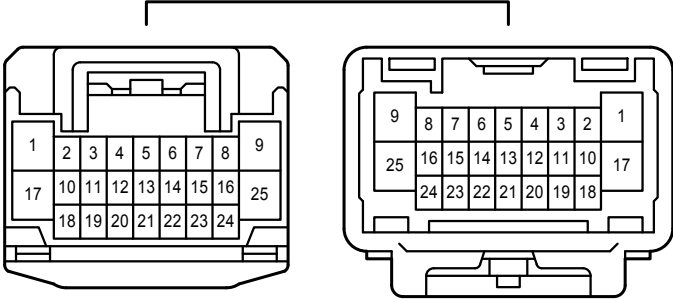

AF4
Gray

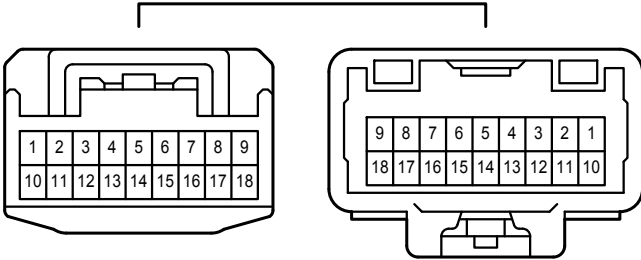

AG1
White

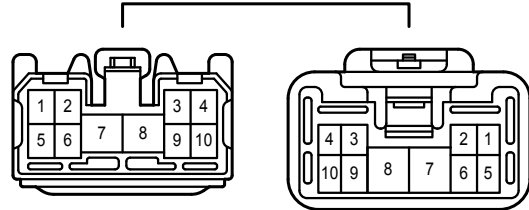

FG1
White

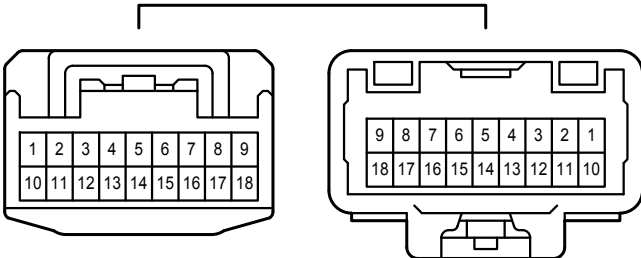

Cruise Control

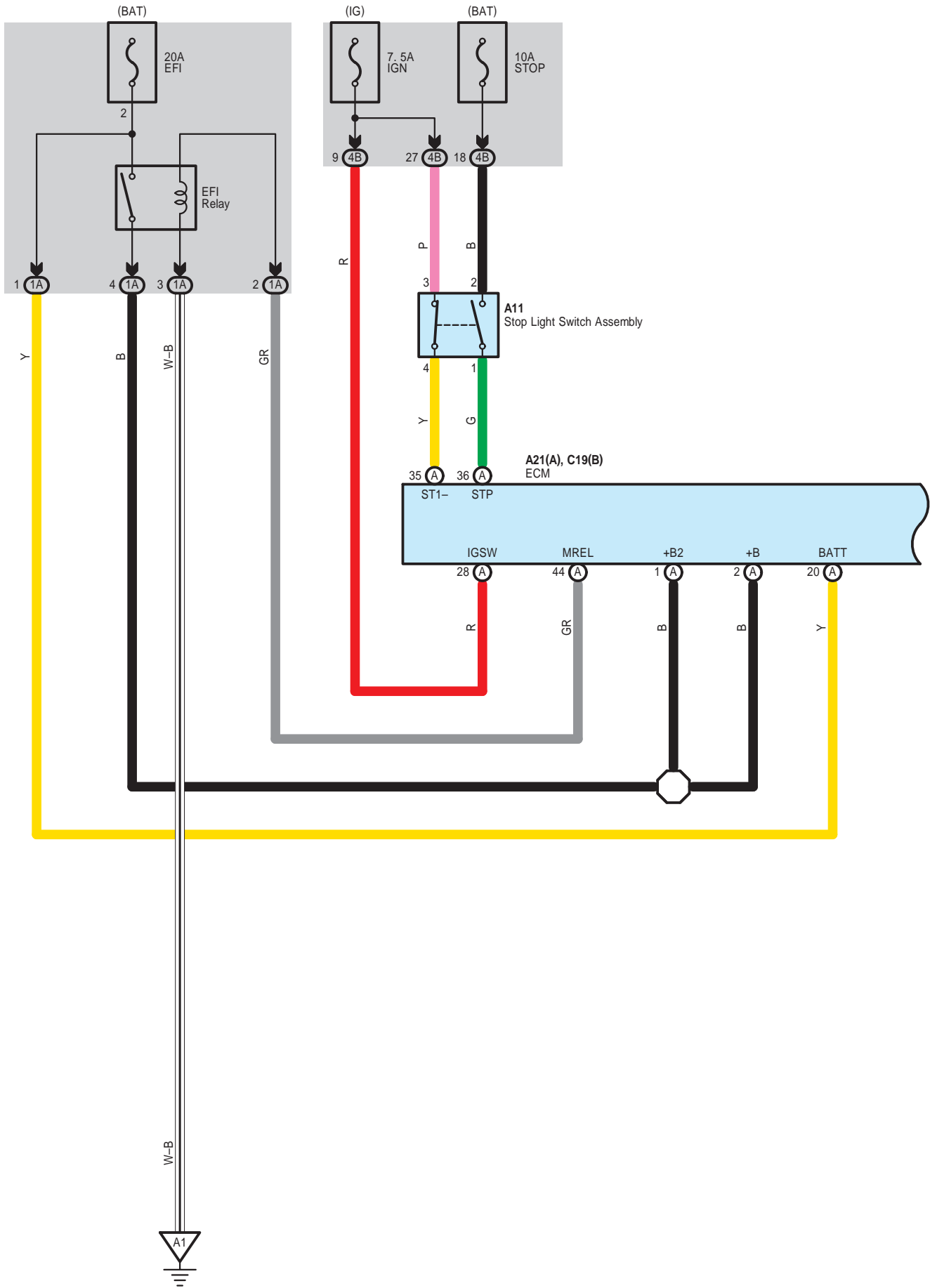

A20
Accelerator Pedal Assembly

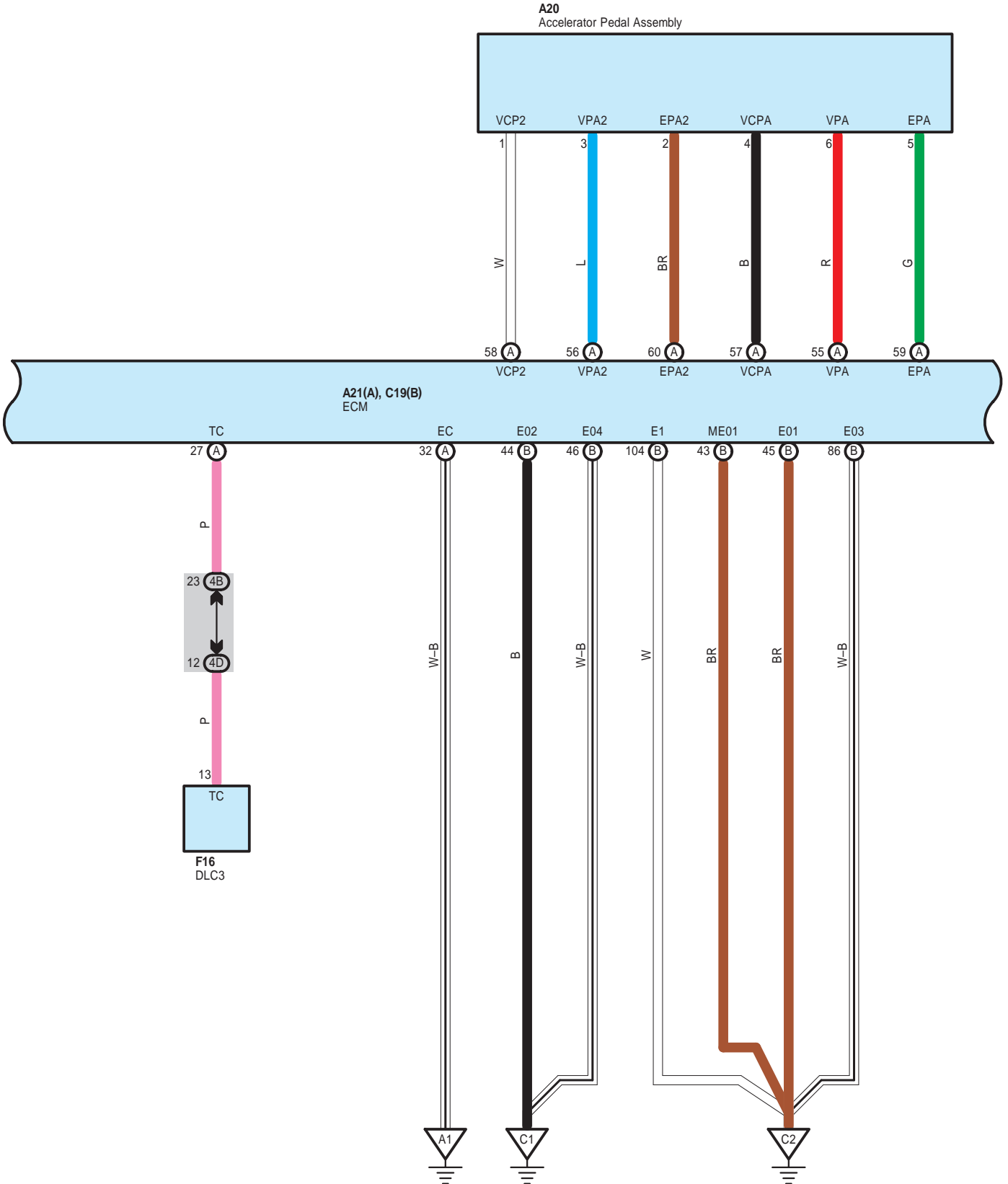

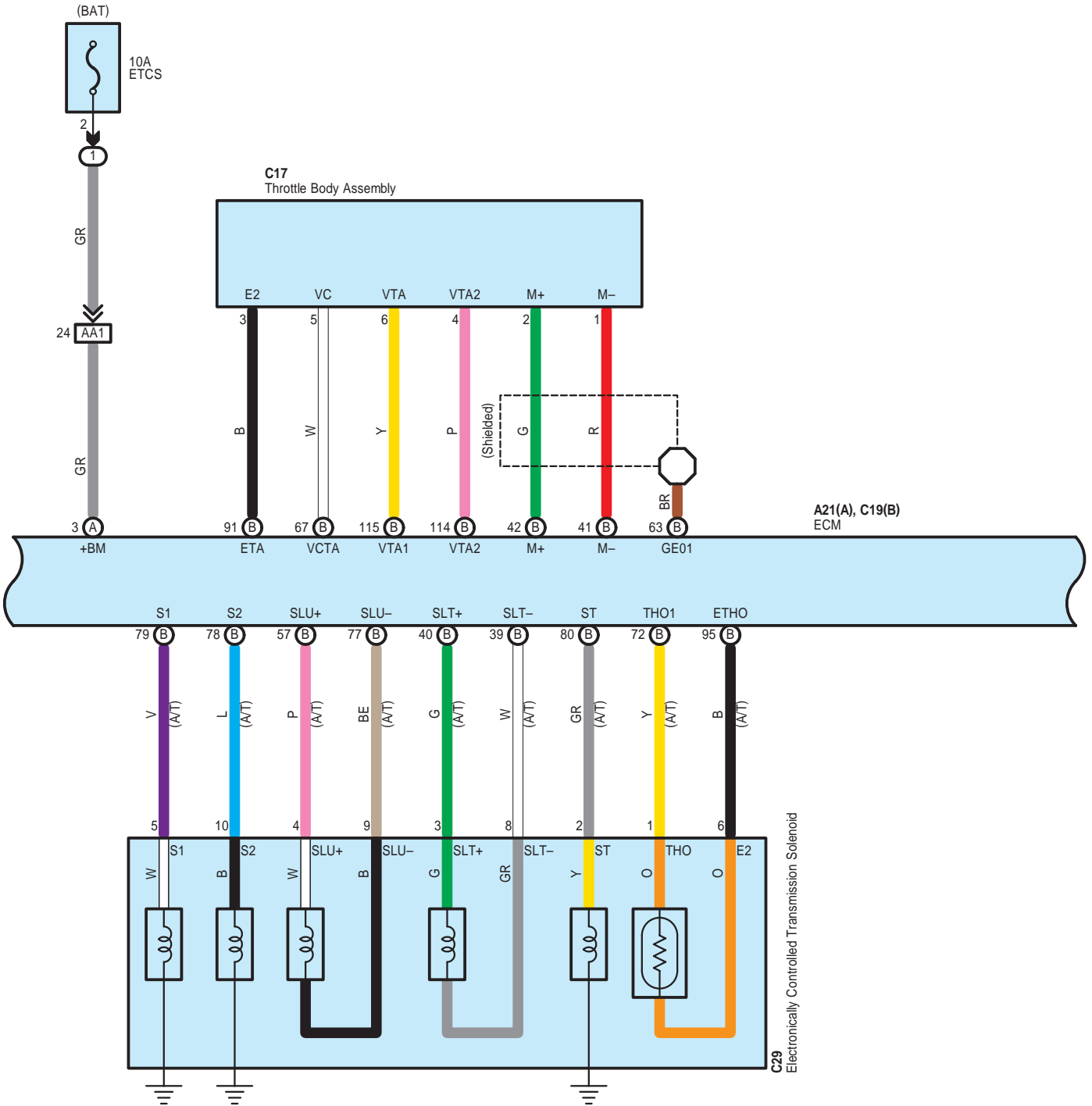

Cruise Control

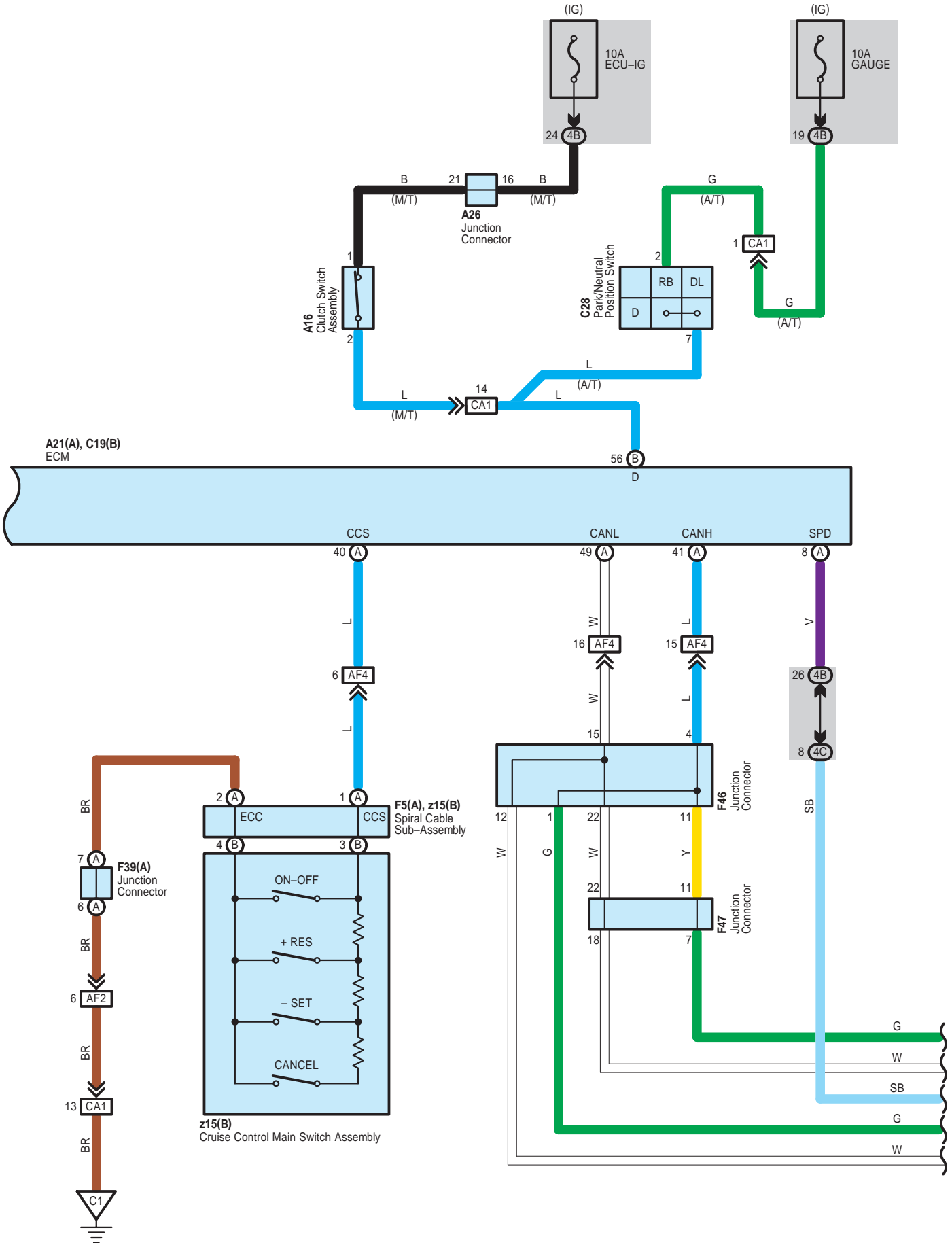

Cruise Control

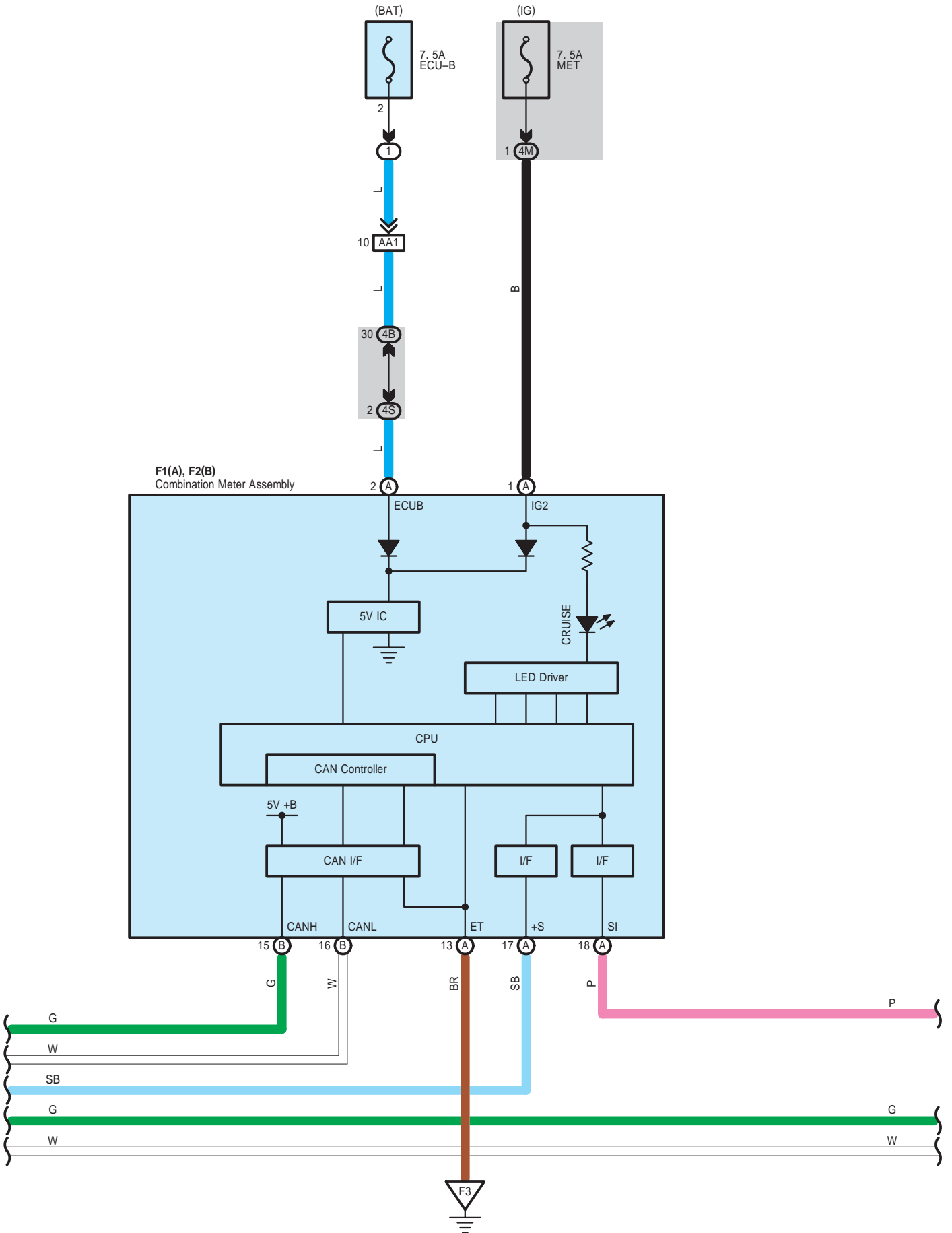

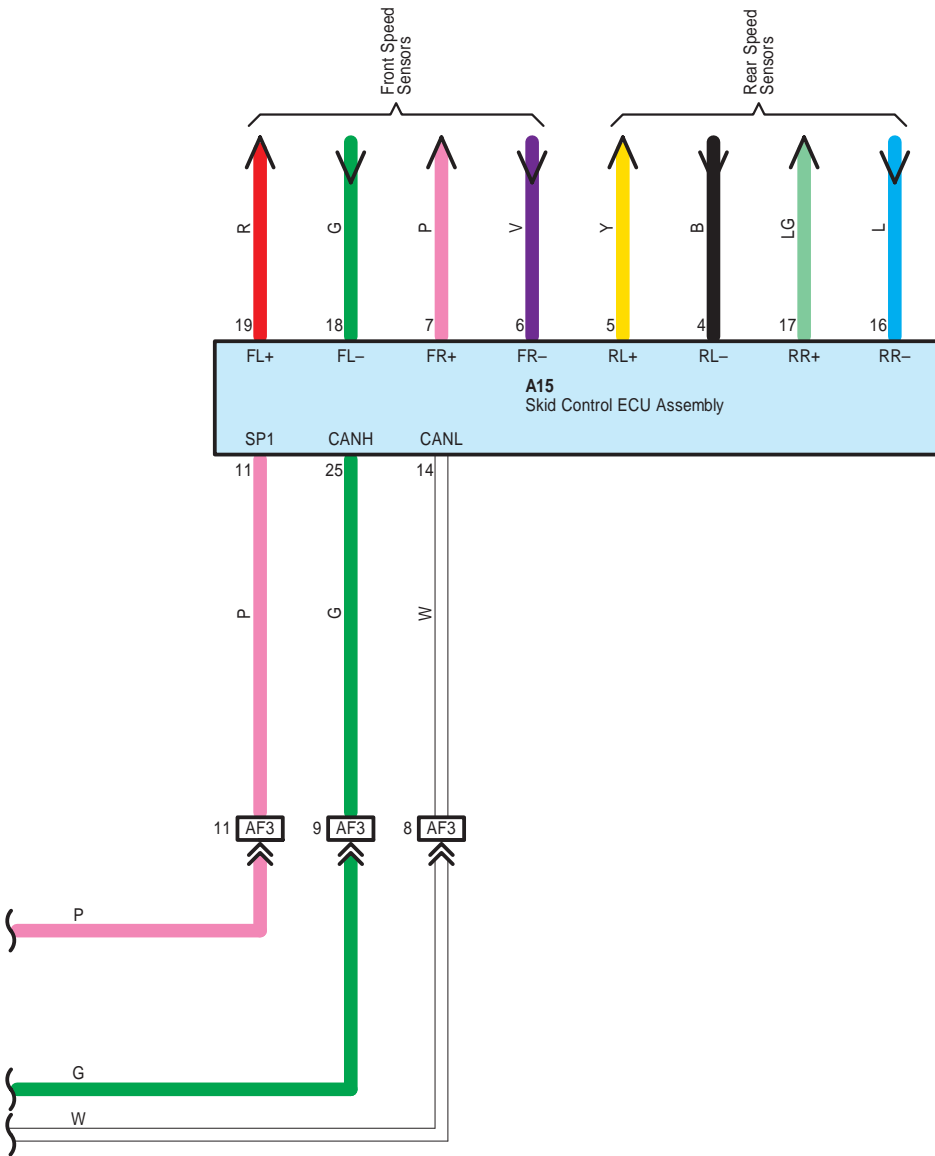

Cruise Control

A 11

White

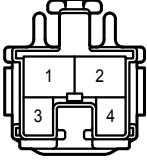

A 15

Black

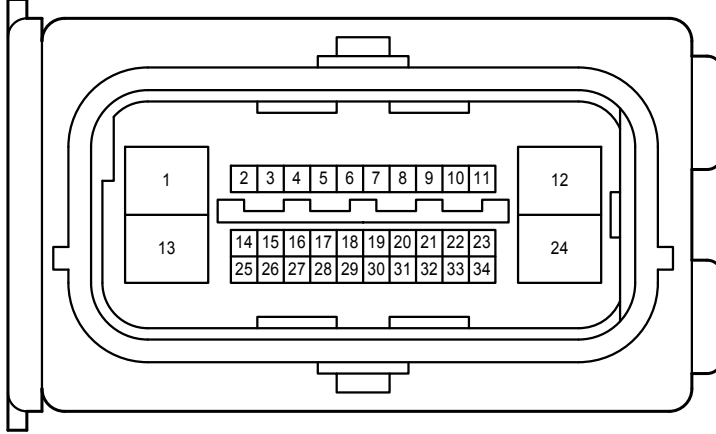

A 16

White

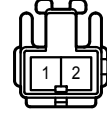

A 20

Black

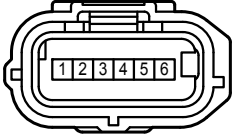

A 21

Black

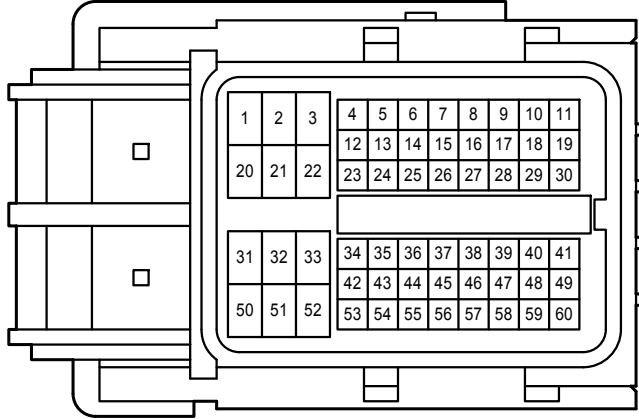

A 26

White

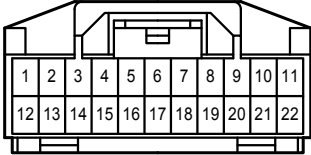

C 17

Black

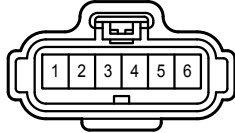

C 19

Black

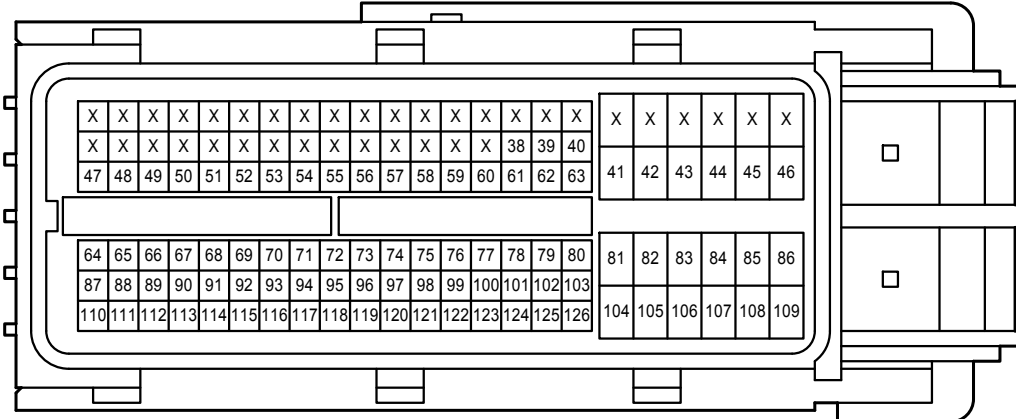

Cruise Control

C 28
Gray

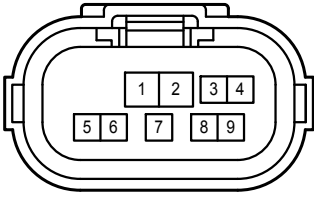

C 29
Gray

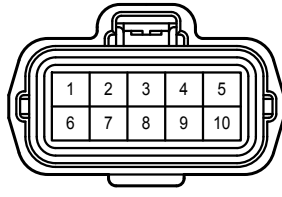

F 1
White

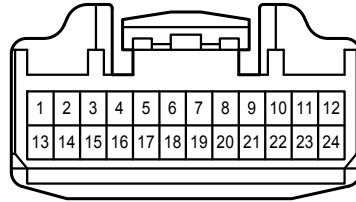

F 2
White

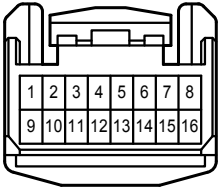

F 5
White

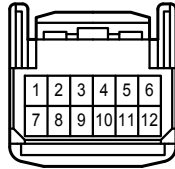

F 16
White

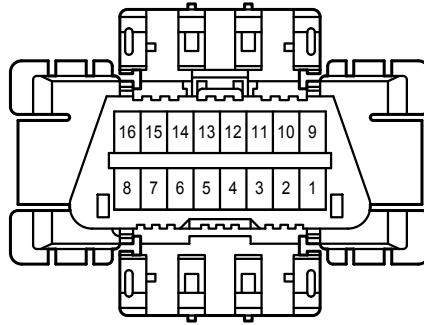

F 39
White

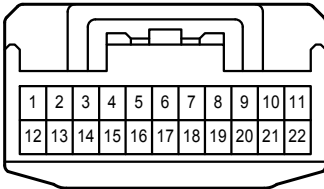

F 46
White

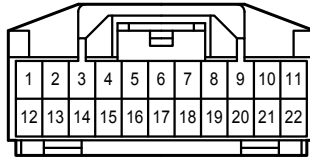

F 47
White

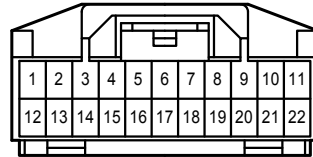

z 15
White

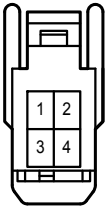

1A
White

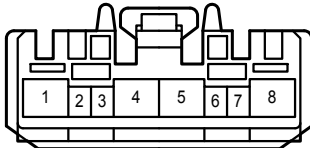

4B
White

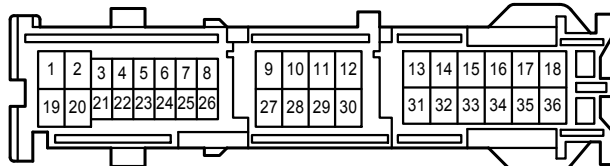

4C
White

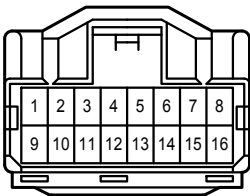

4D
White

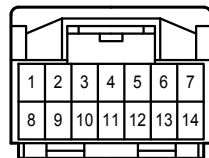

4M
White

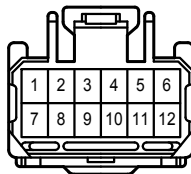

4S
White

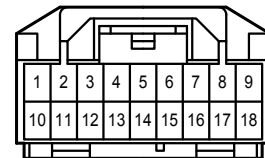

Cruise Control

AA1
White

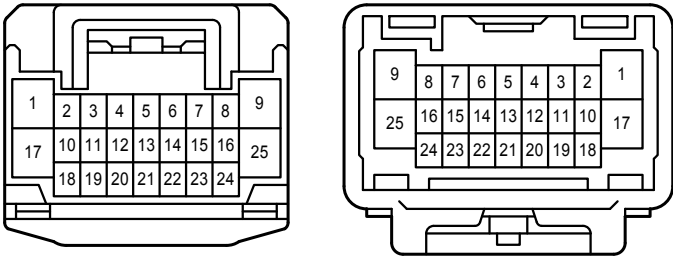

AF2
White

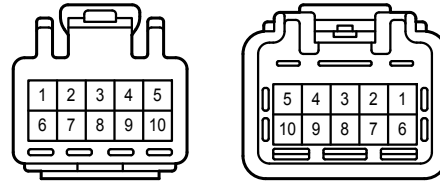

AF3
Black

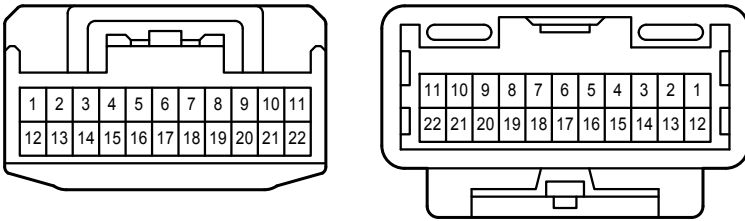

AF4
Gray

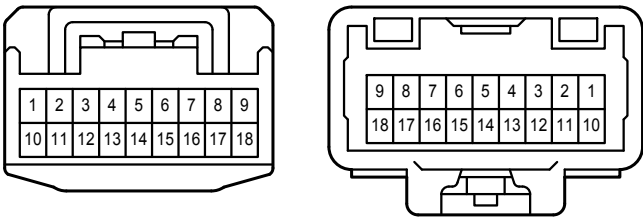

CA1
White

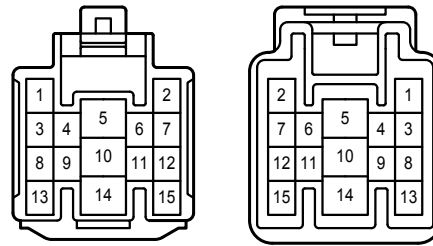

Data Link Connector 3

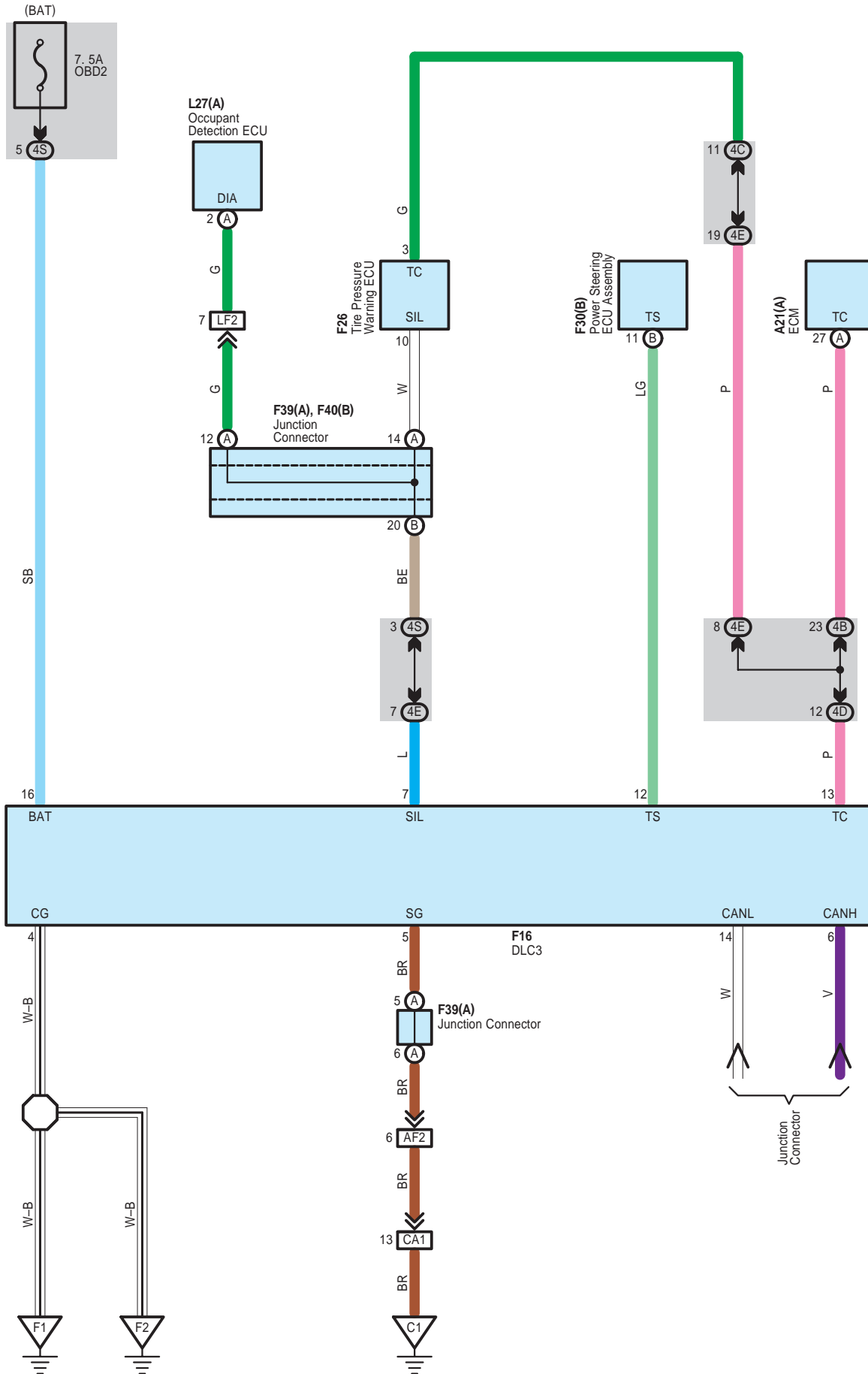

Data Link Connector 3

A 21
Black

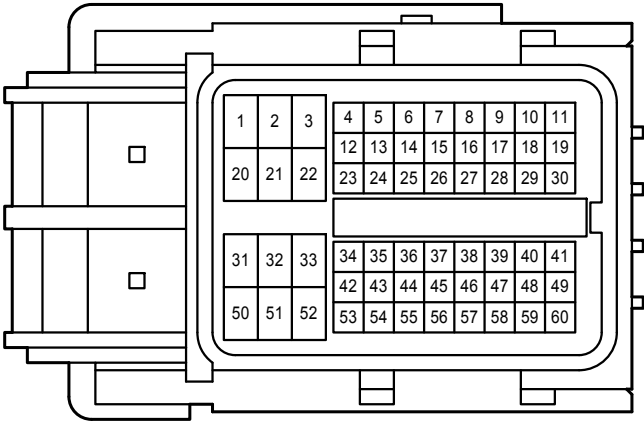

F 16
White

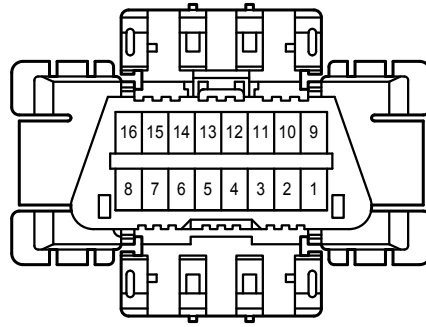

F 26
White



F 30
White

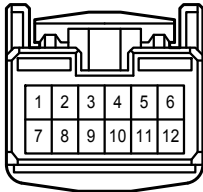

F 39
White

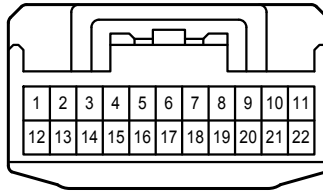

F 40
White

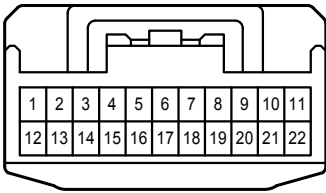

L 27
Black

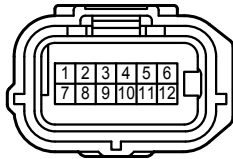

4B
White

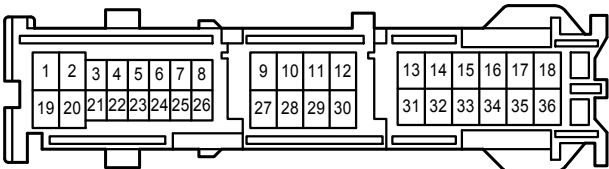

4C
White

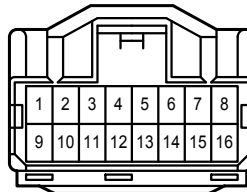

4D
White

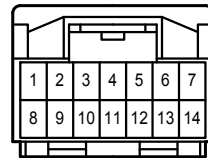

4E
White

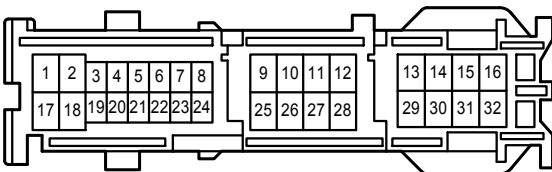

4S
White

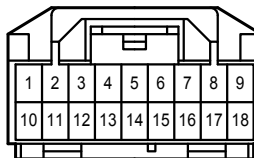

Data Link Connector 3

AF2
White

CA1
White

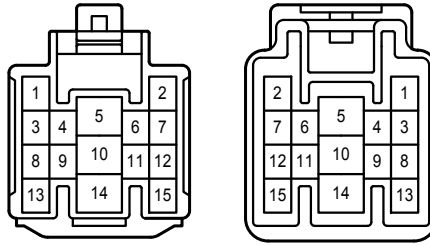
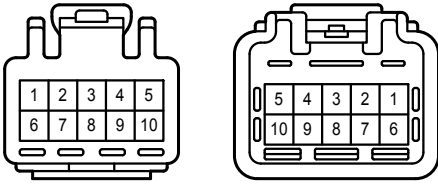

LF2
White

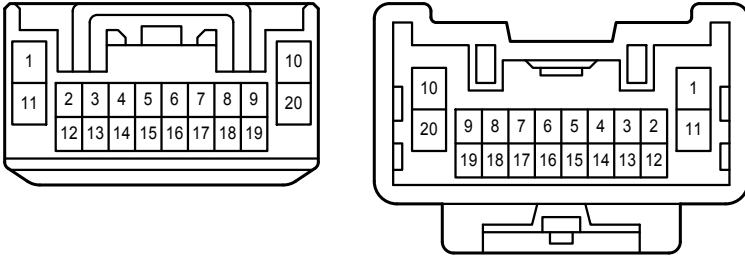

Door Lock Control

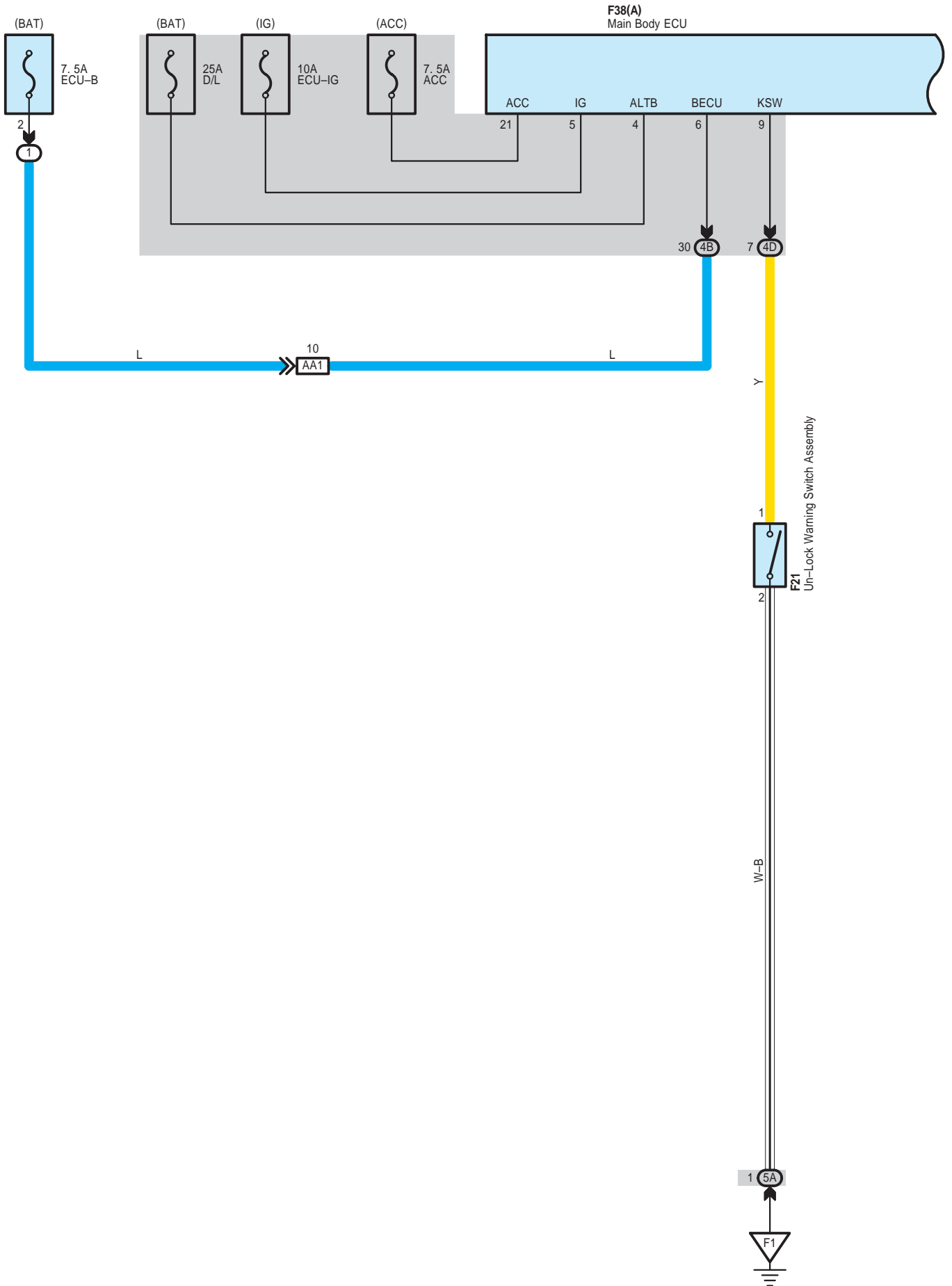

Door Lock Control

F38(A)
Main Body ECU

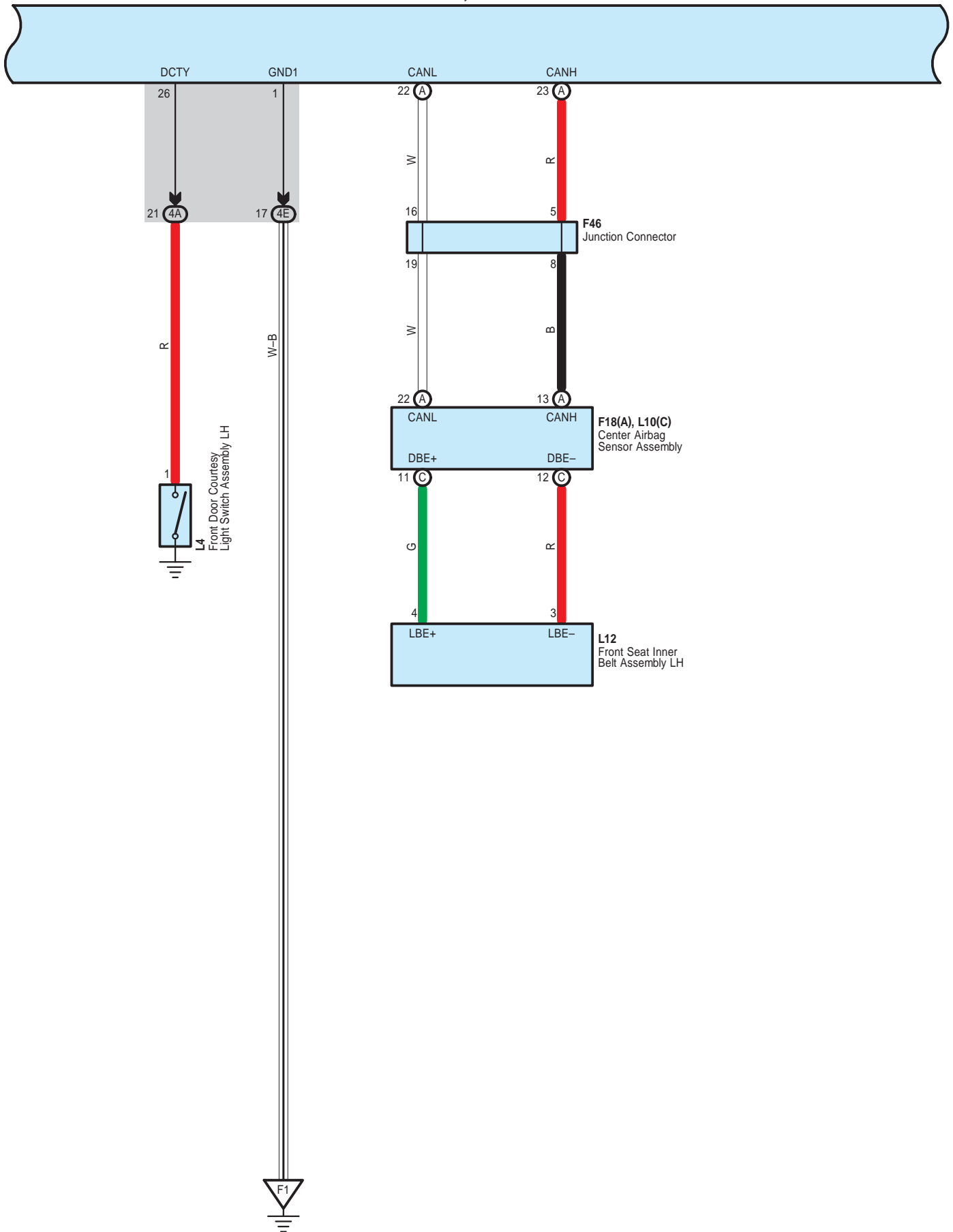

Door Lock Control

F38(A)
Main Body ECU

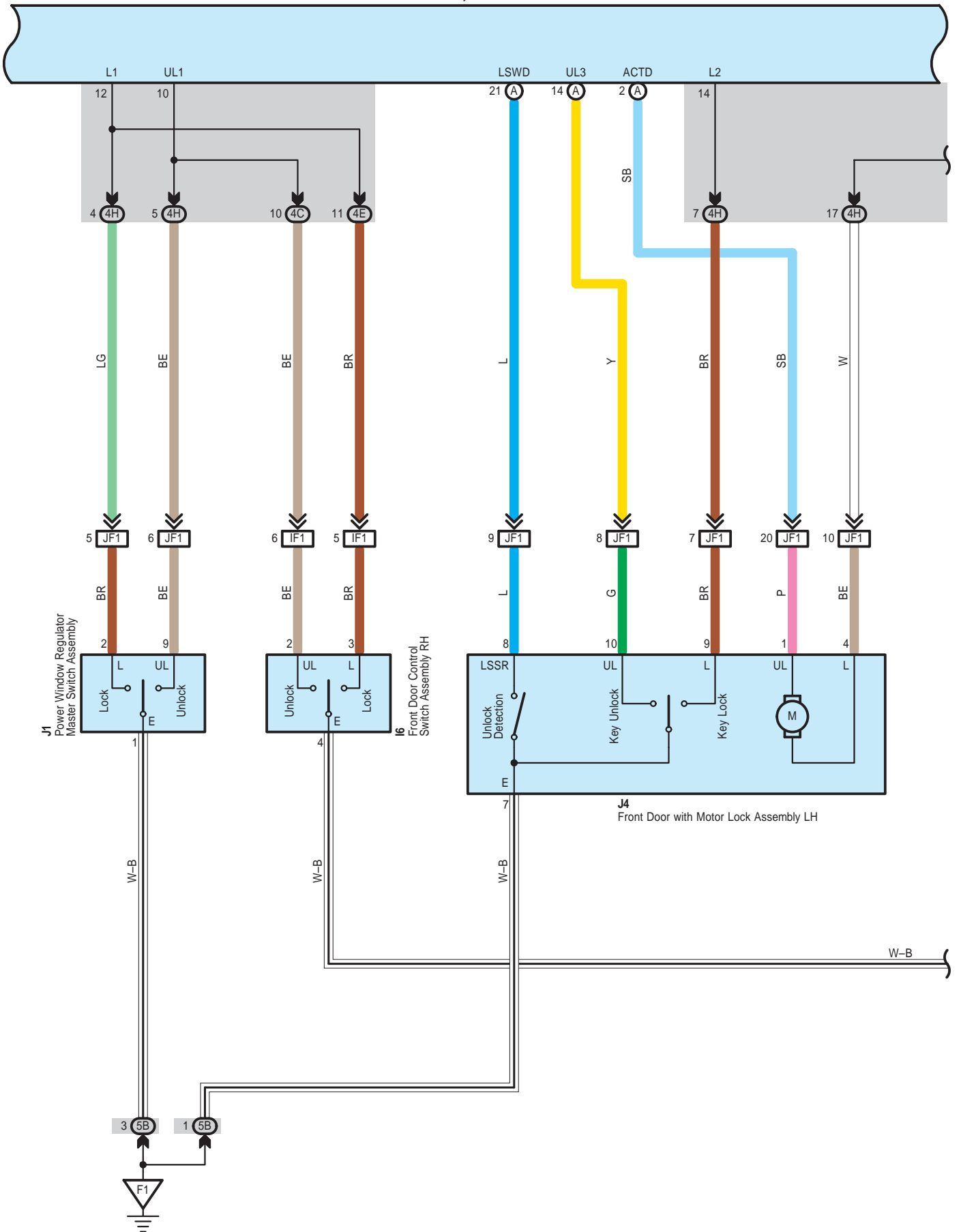

Door Lock Control

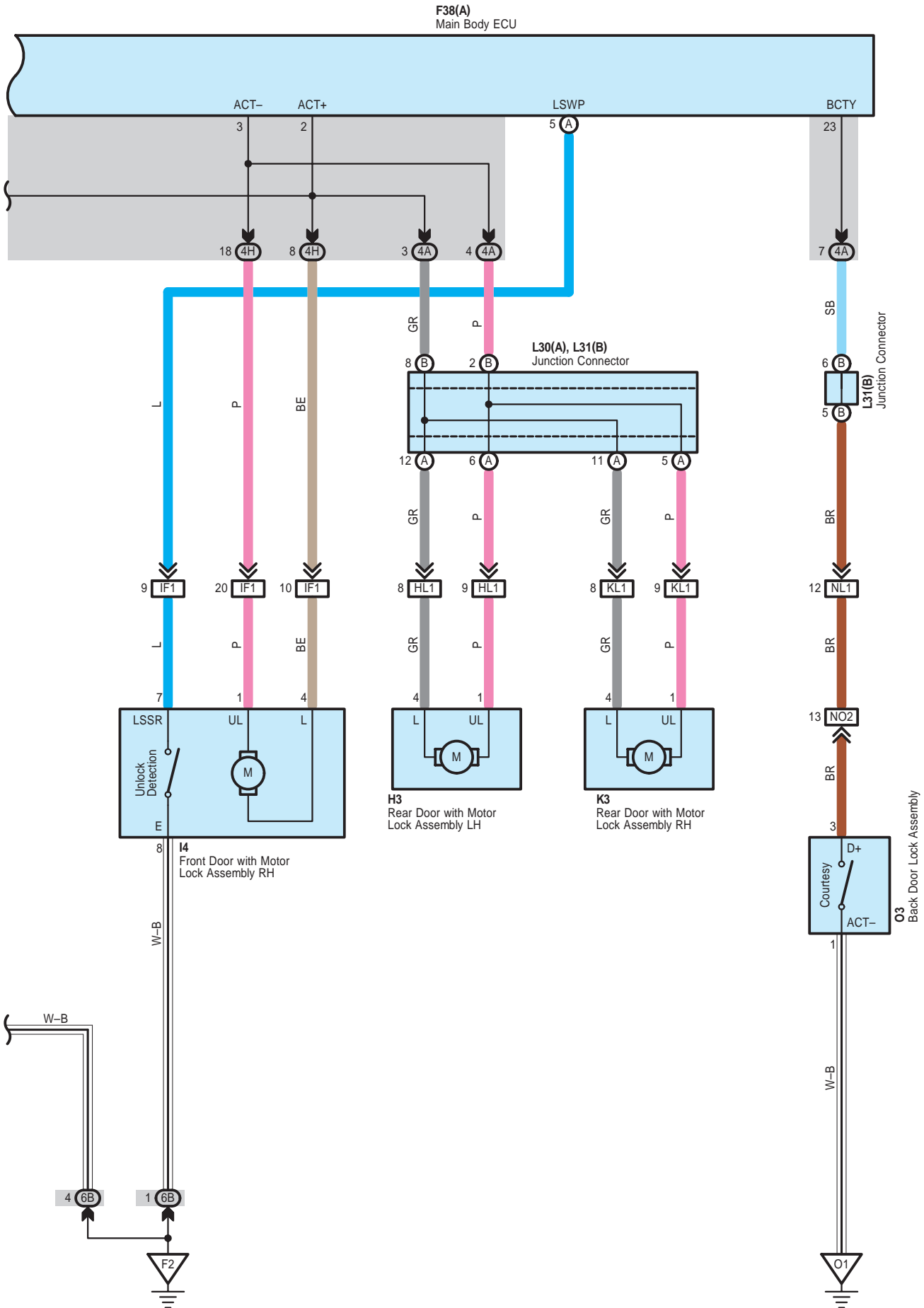

Door Lock Control

F 18
Yellow

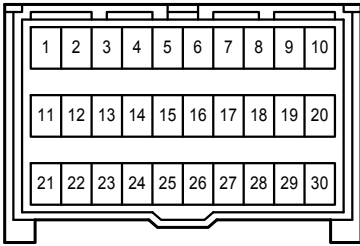

F 21
White



F 38
White

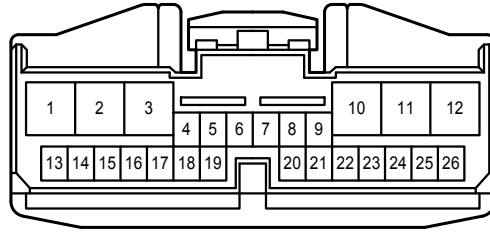

F 46
White

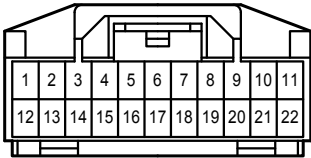

H 3
White

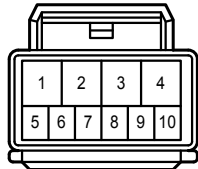

I 4
White

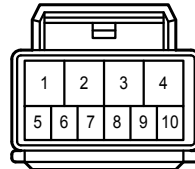

I 6
White

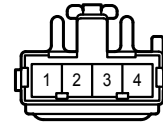

J 1
White

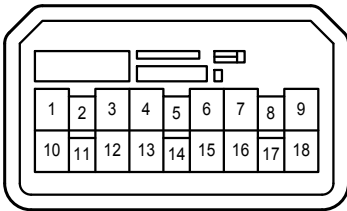

J 4
White

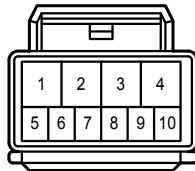

K 3
White

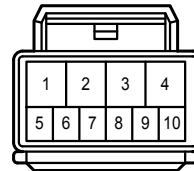

L 4
White



L 10
Yellow

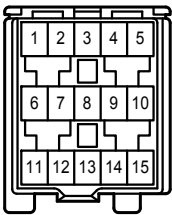

L 12
White



L 30
White

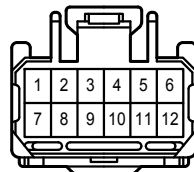

L 31
White

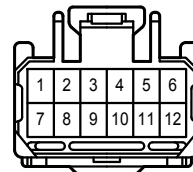

O 3
Black

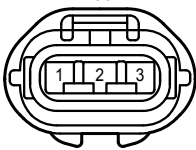

4A
White

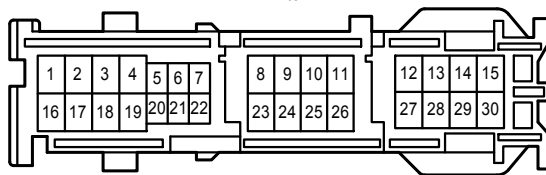

4B
White

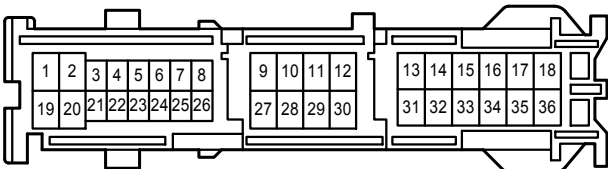

4C
White

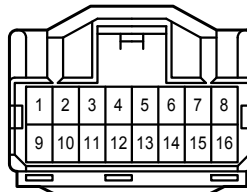

4D
White

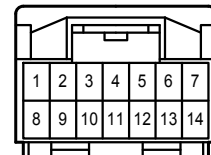

Door Lock Control

4E
White

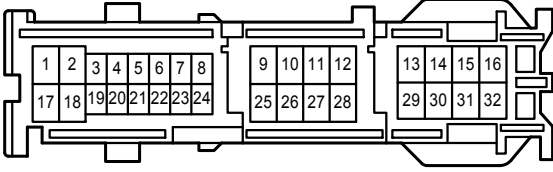

4H
White

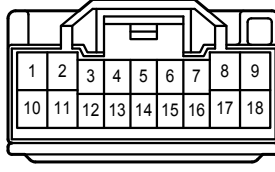

5A
White

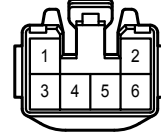

5B
White



6B
White

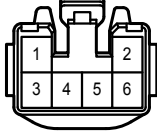

AA1
White

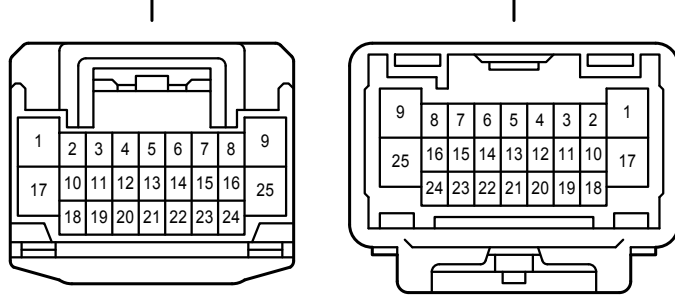

HL1
White

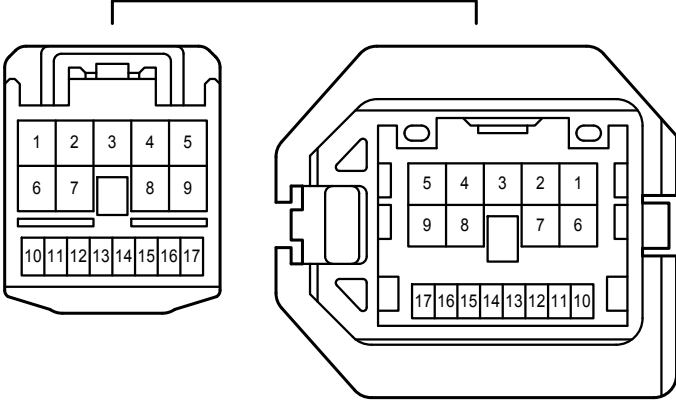

IF1
White

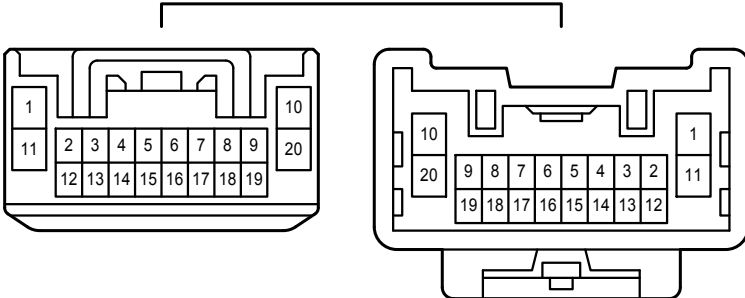

Door Lock Control

JF1
White

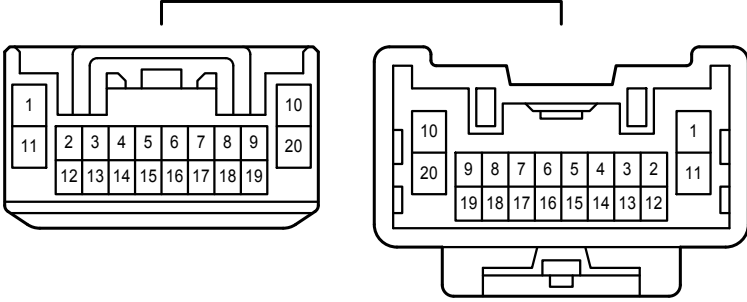

KL1
White

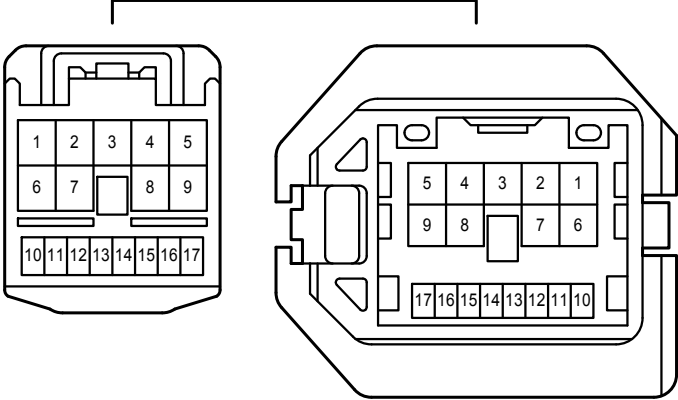

NL1
White

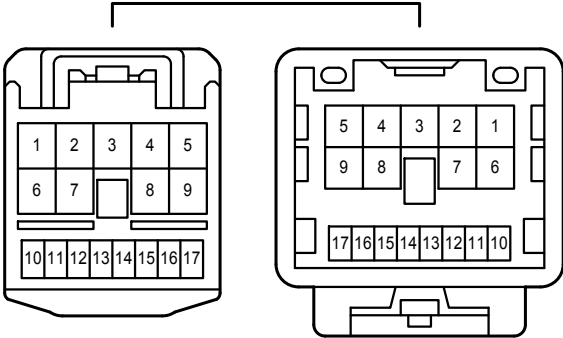

NO2
White

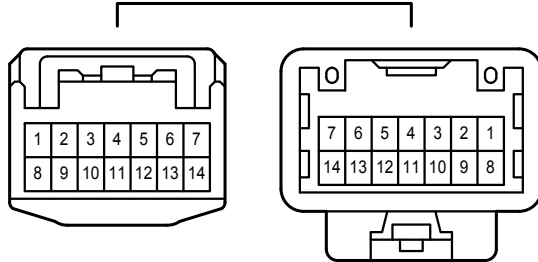

Electronically Controlled Transmission and A/T Indicator

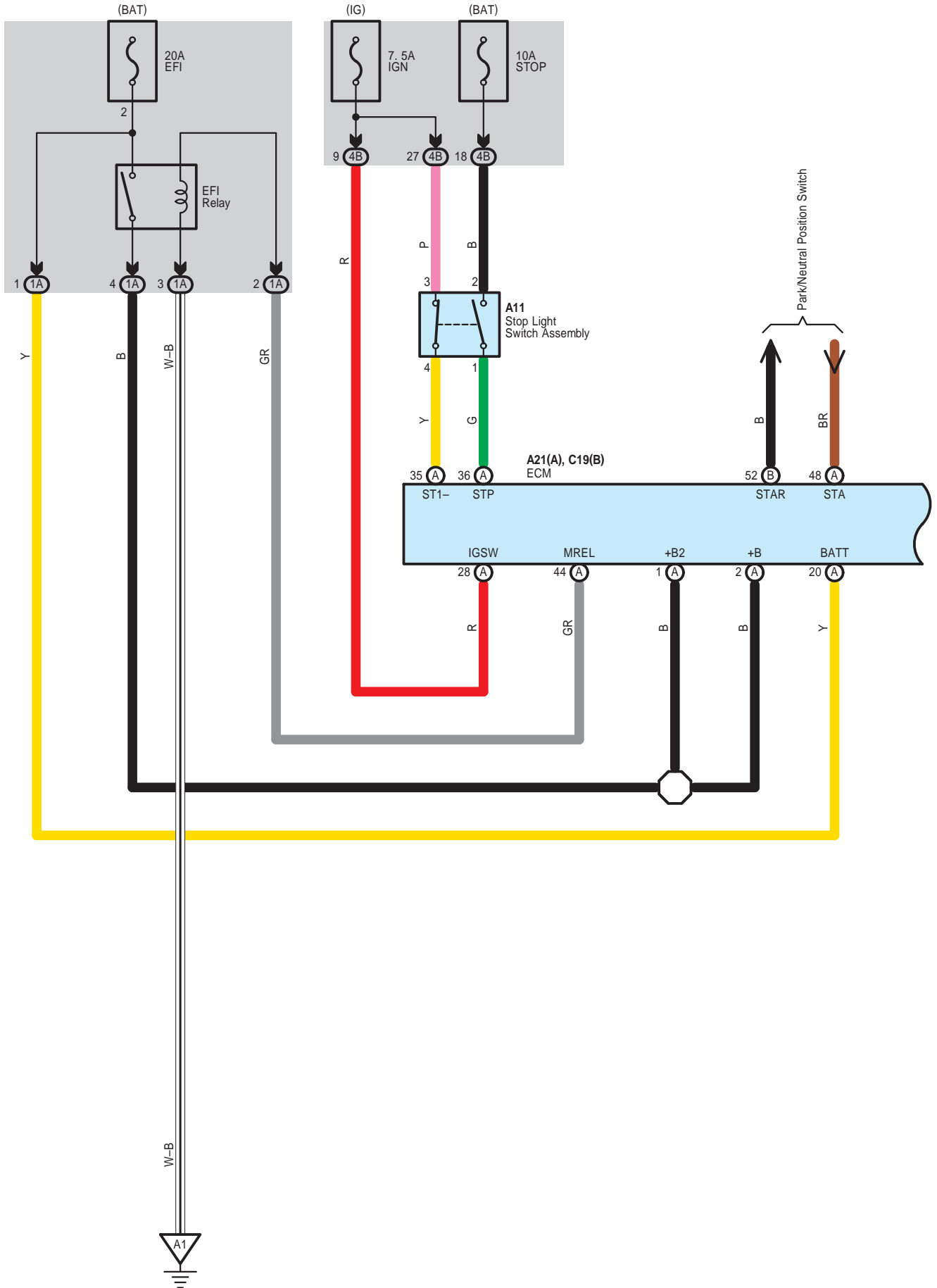

Electronically Controlled Transmission and A/T Indicator

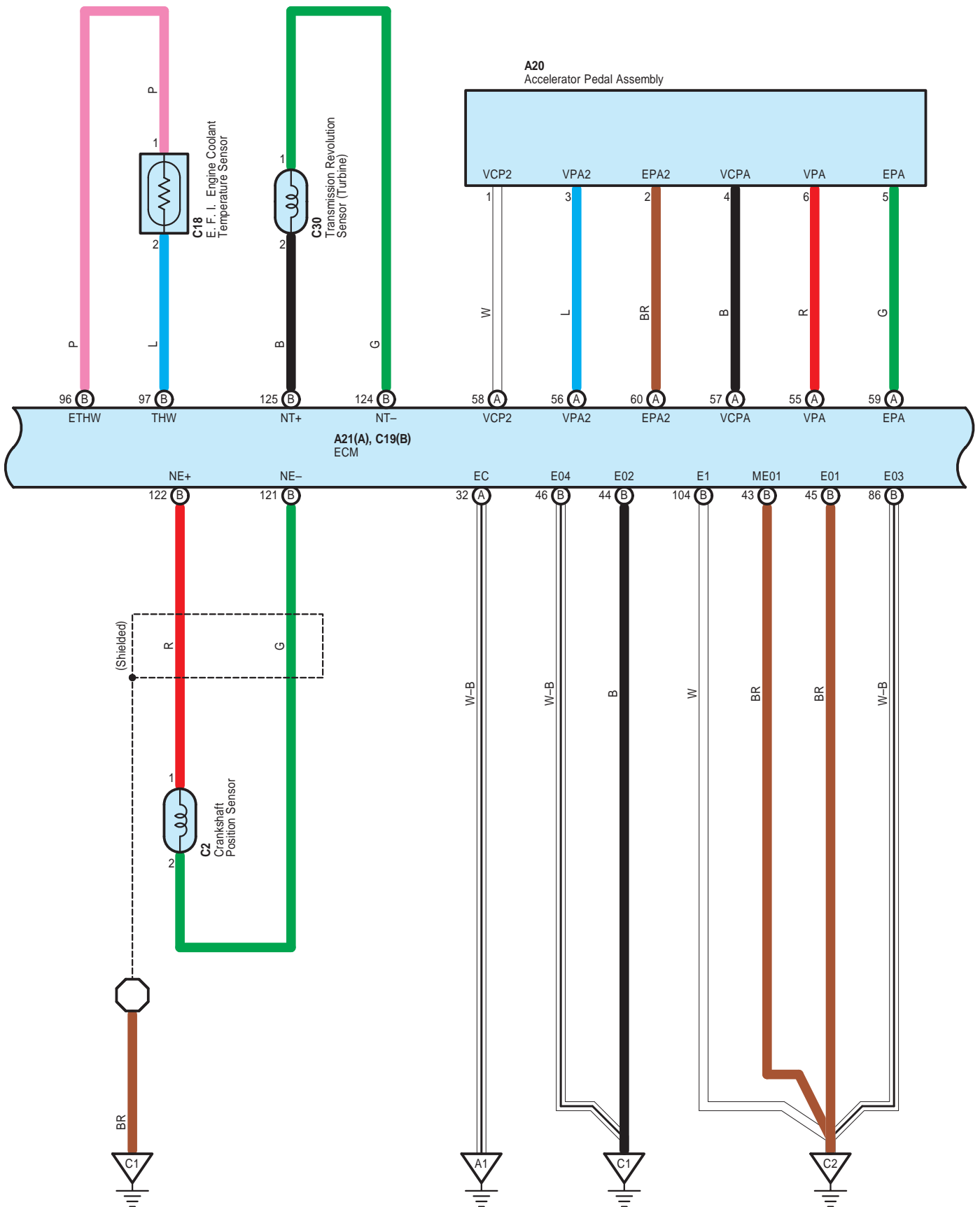

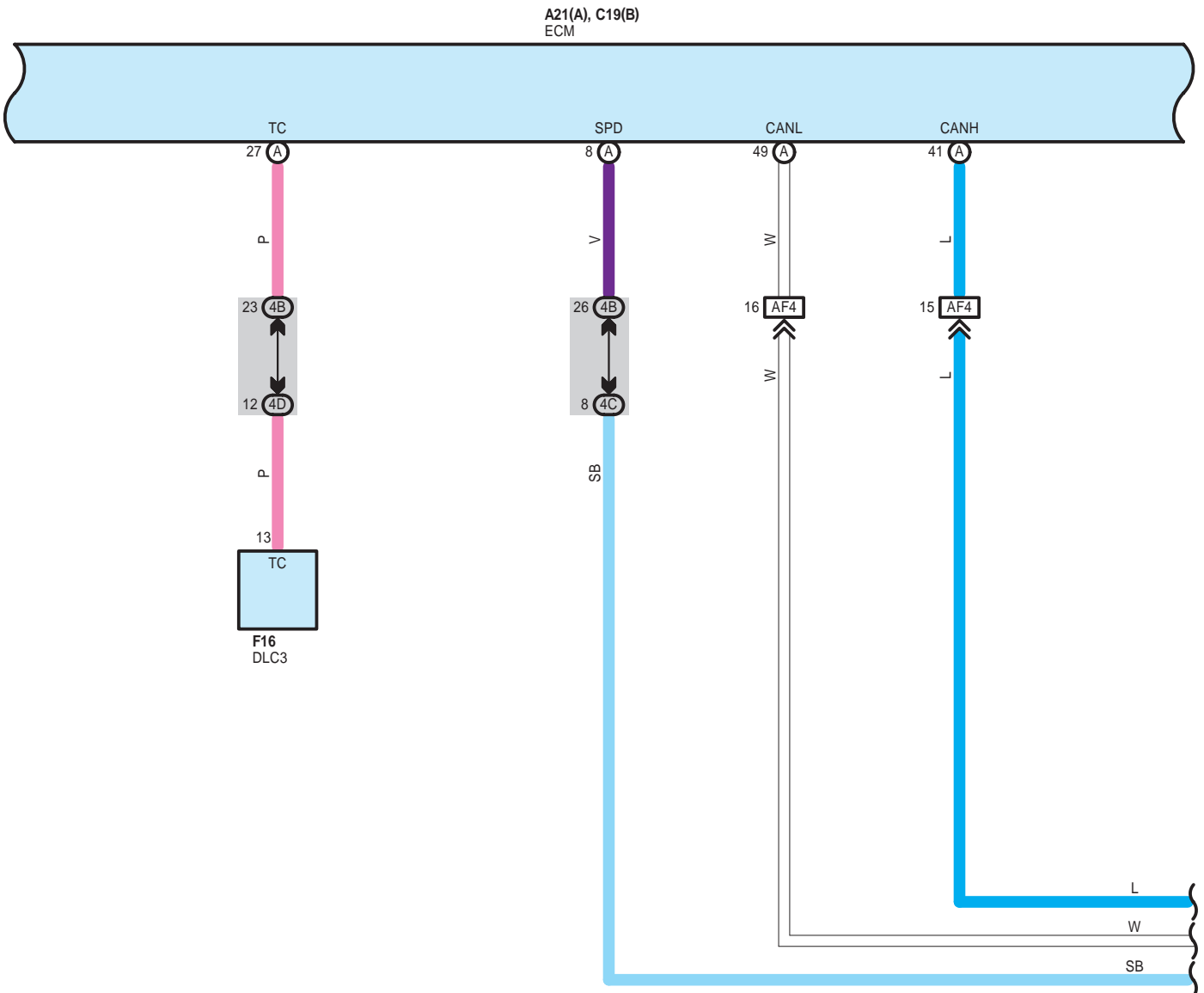

Electronically Controlled Transmission and A/T Indicator

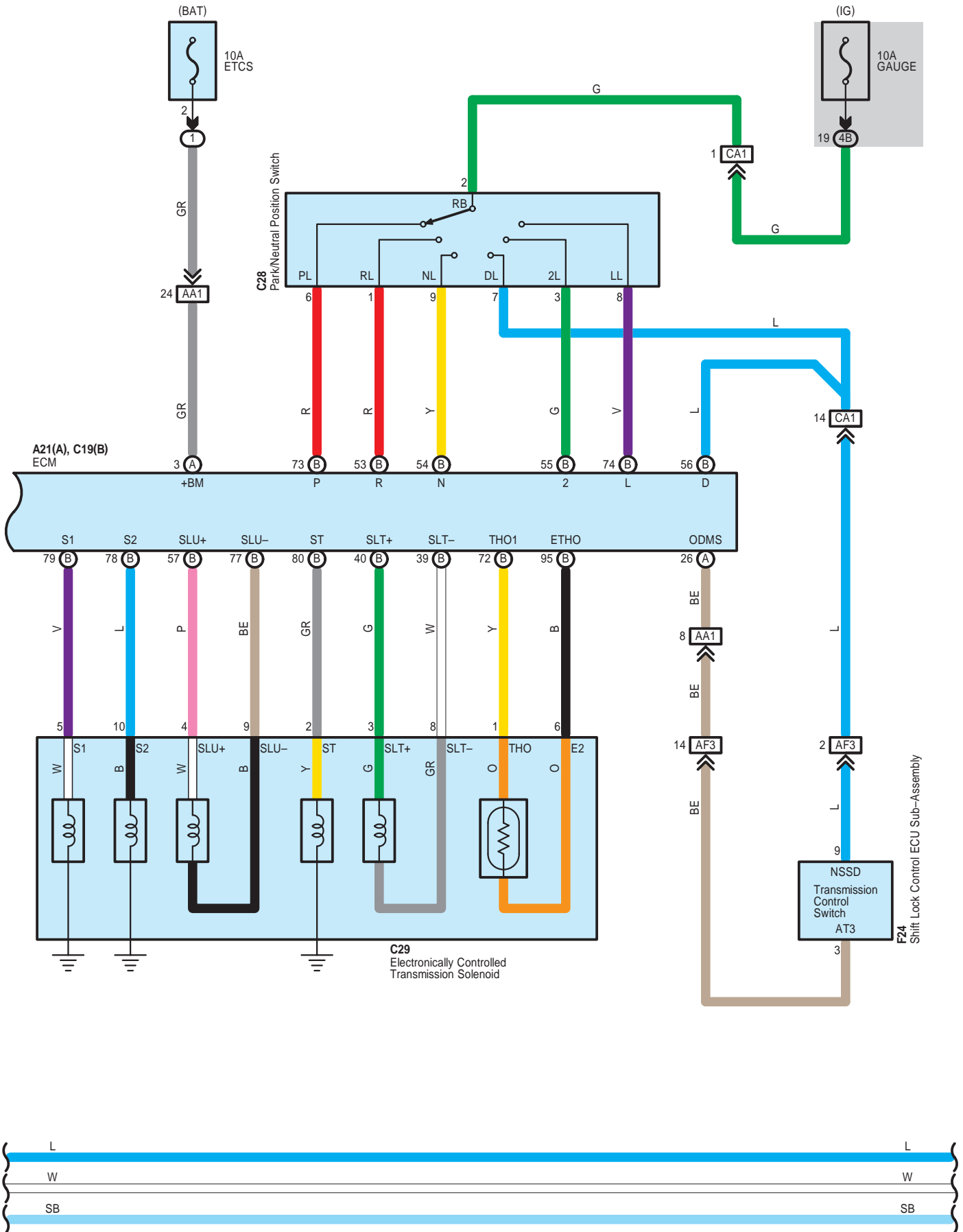

Electronically Controlled Transmission and A/T Indicator

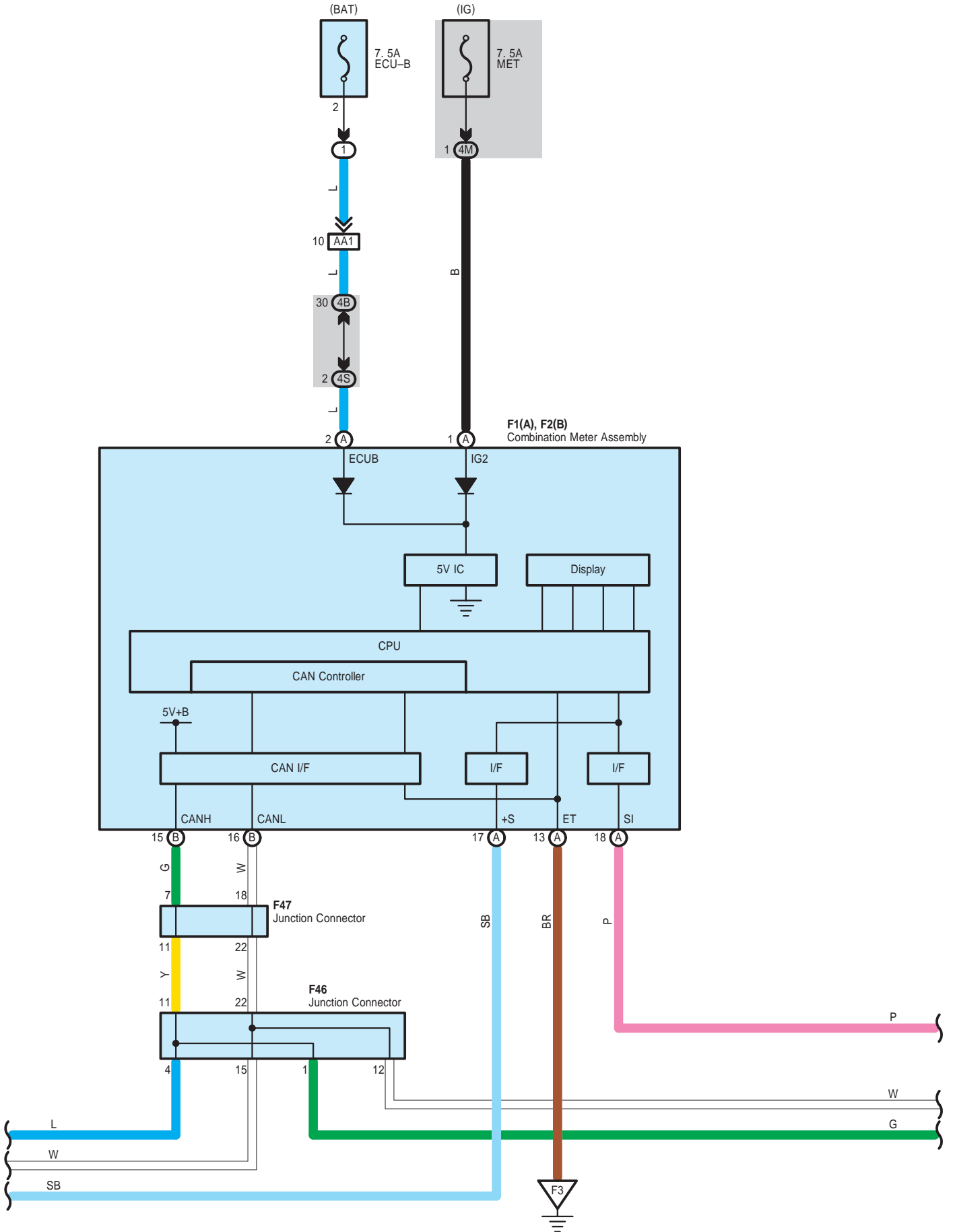

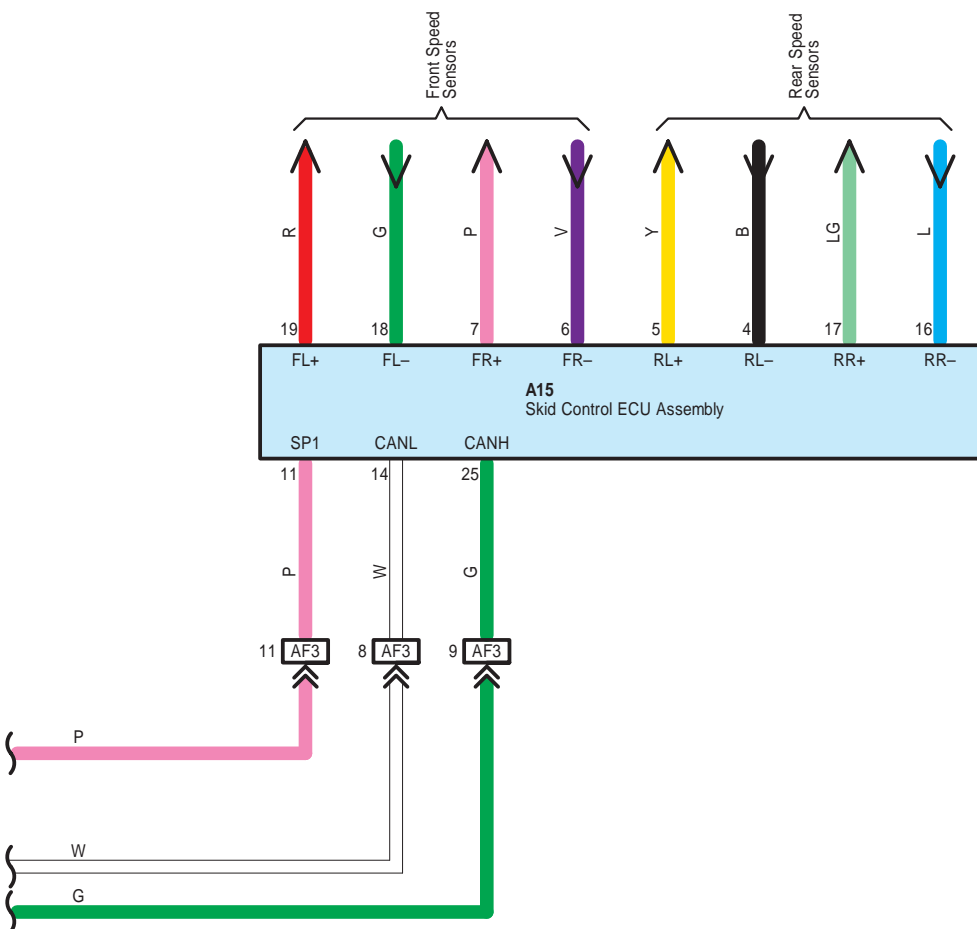

Electronically Controlled Transmission and A/T Indicator

A 11

White

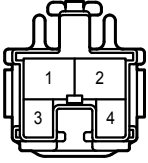

A 15

Black

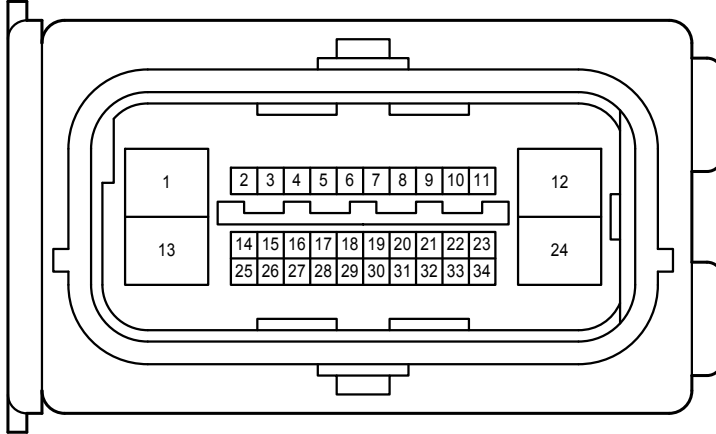

A 20

Black

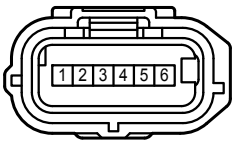

A 21

Black

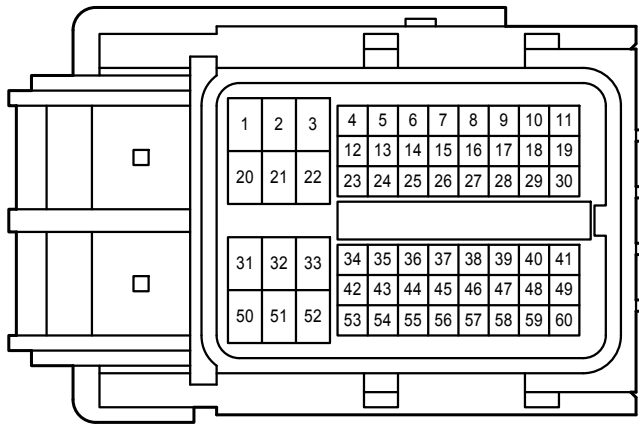

C 2

Black

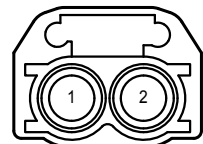

C 18

Black



C 19

Black

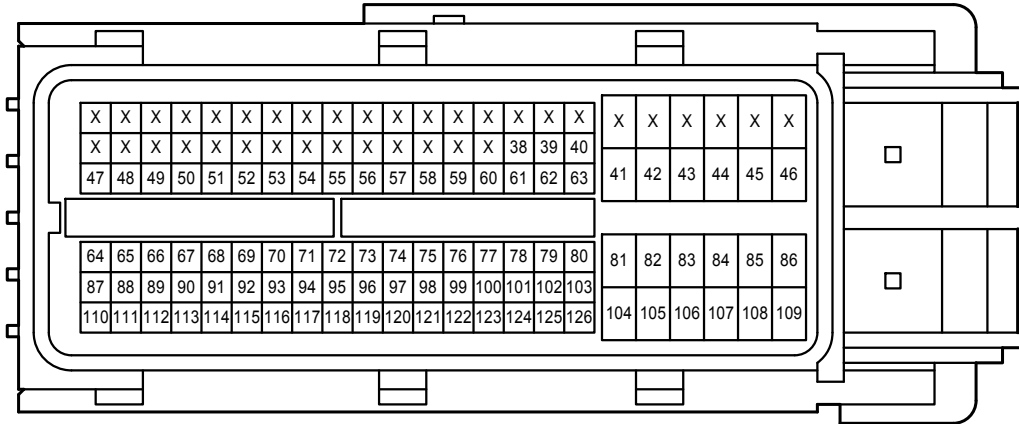

C 28

Gray

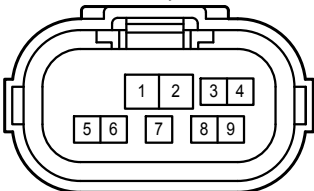

C 29

Gray

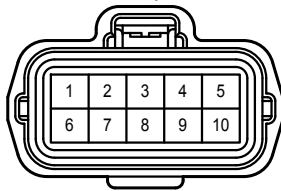

C 30

Black

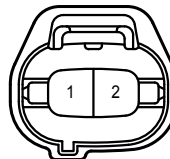

Electronically Controlled Transmission and A/T Indicator

F 1
White

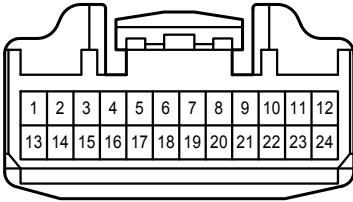

F 2
White

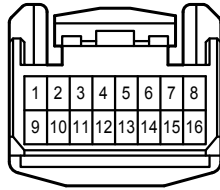

F 16
White

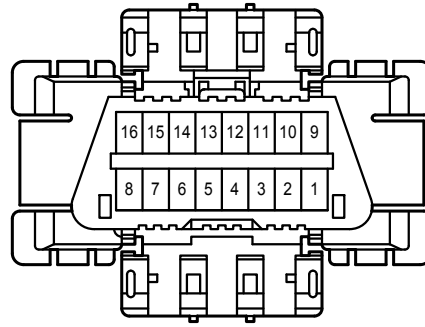

F 24
White



F 46
White

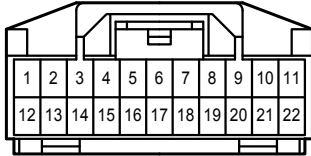

F 47
White

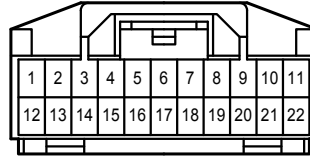

1A
White

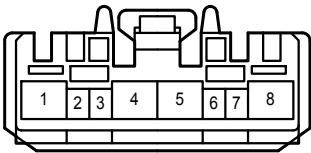

4B
White

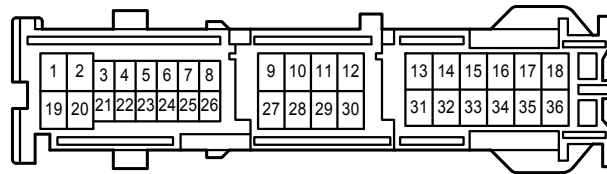

4C
White

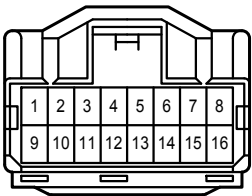

4D
White

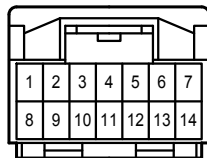

4M
White

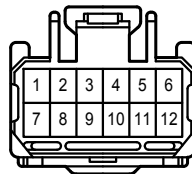

4S
White

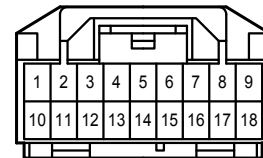

AA1
White

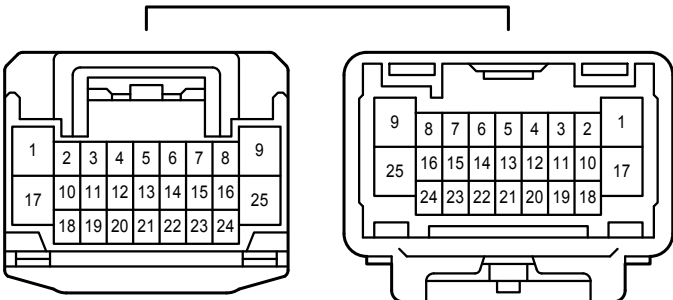

Electronically Controlled Transmission and A/T Indicator

AF3
Black

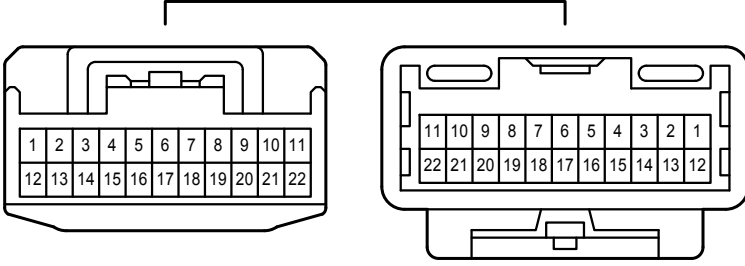

AF4
Gray

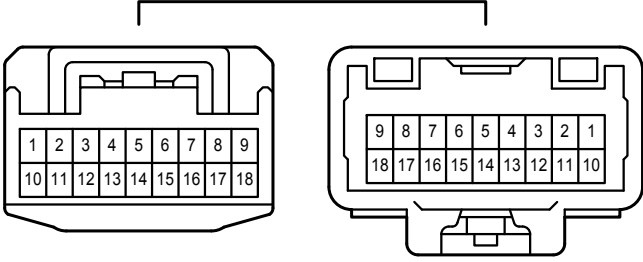

CA1
White

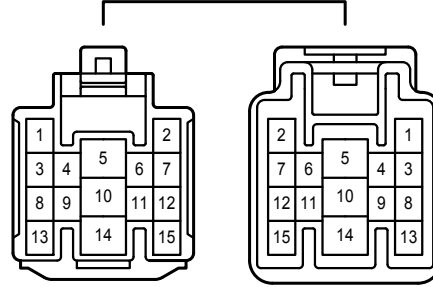

Engine Control

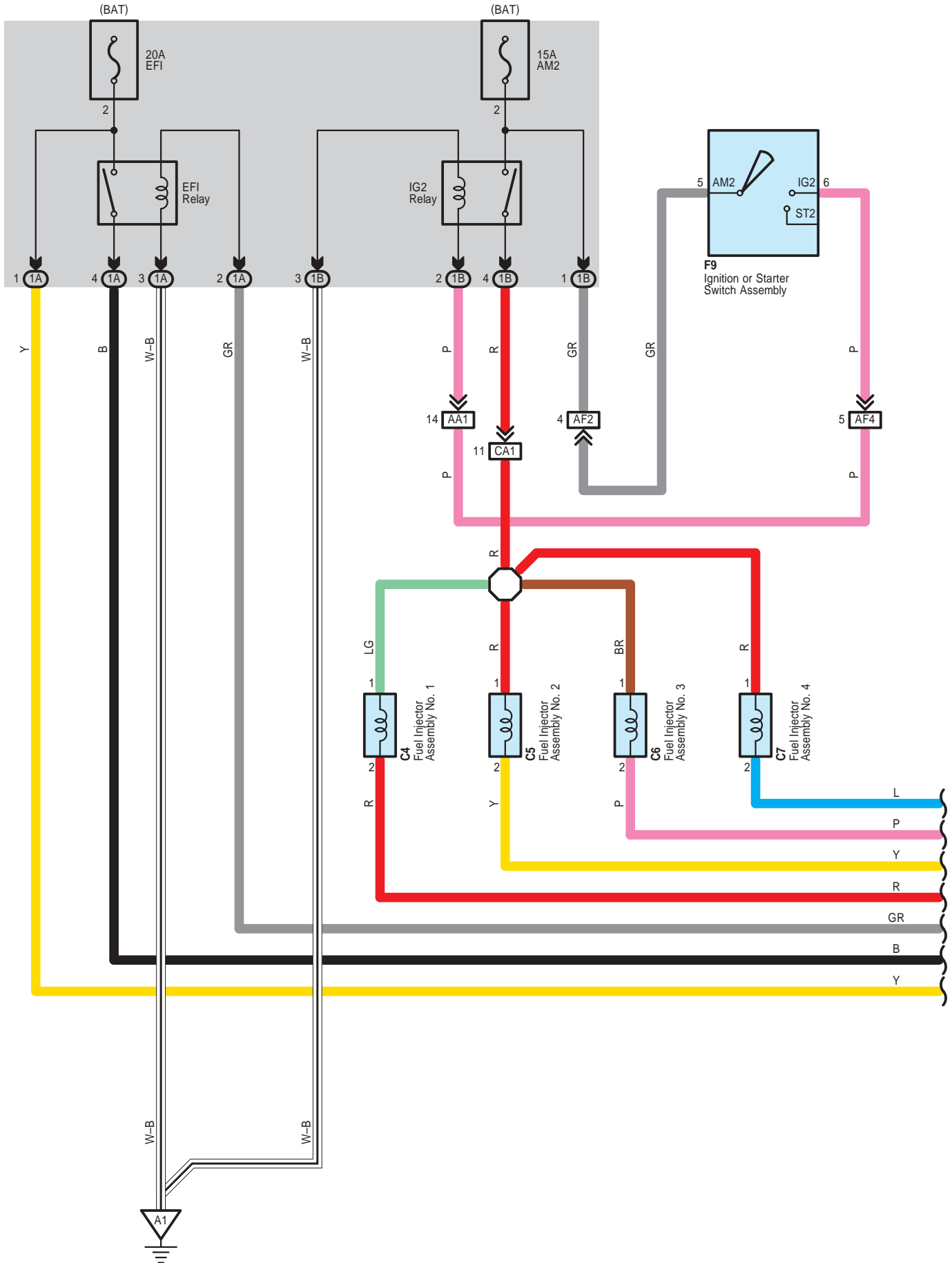

Engine Control

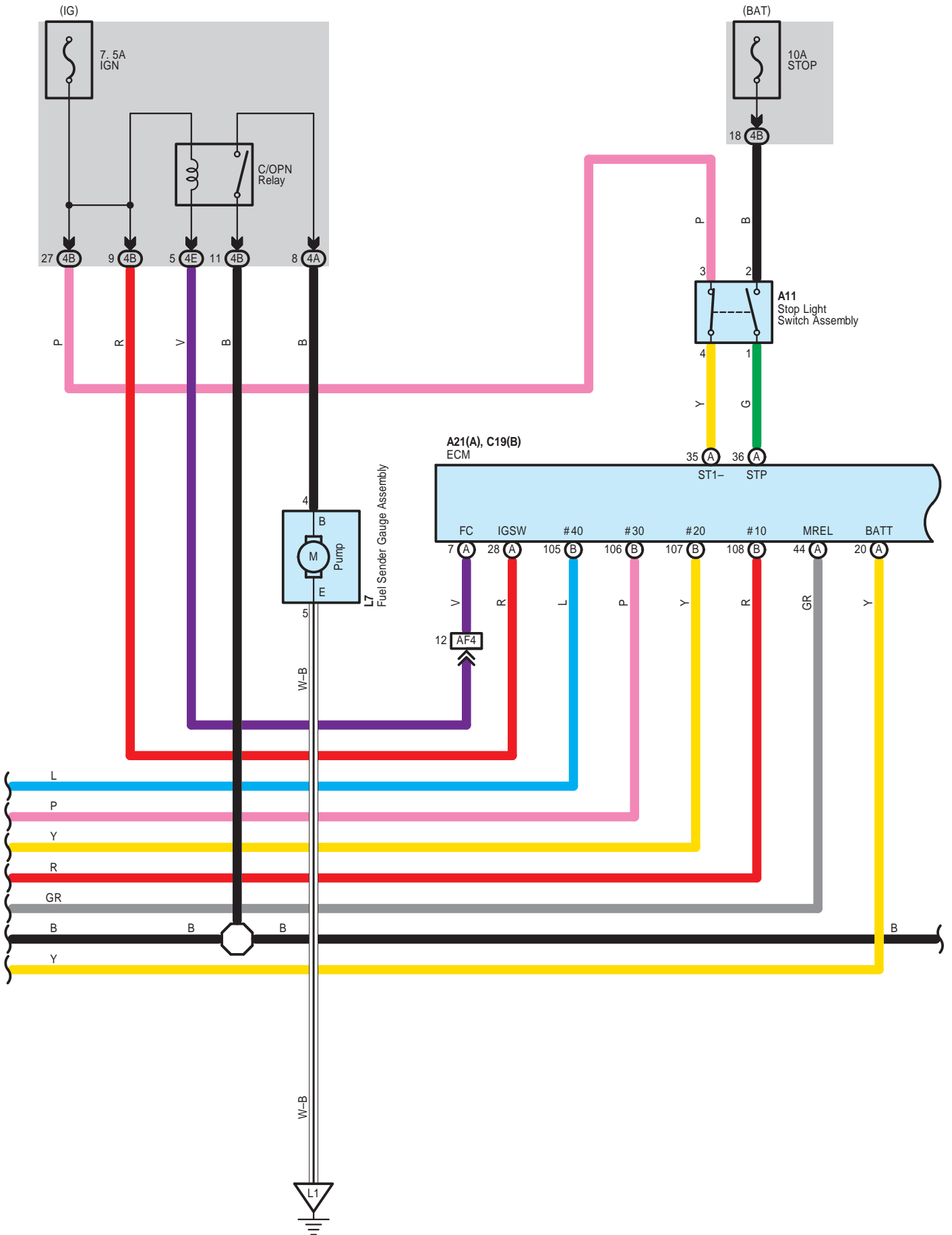

Engine Control

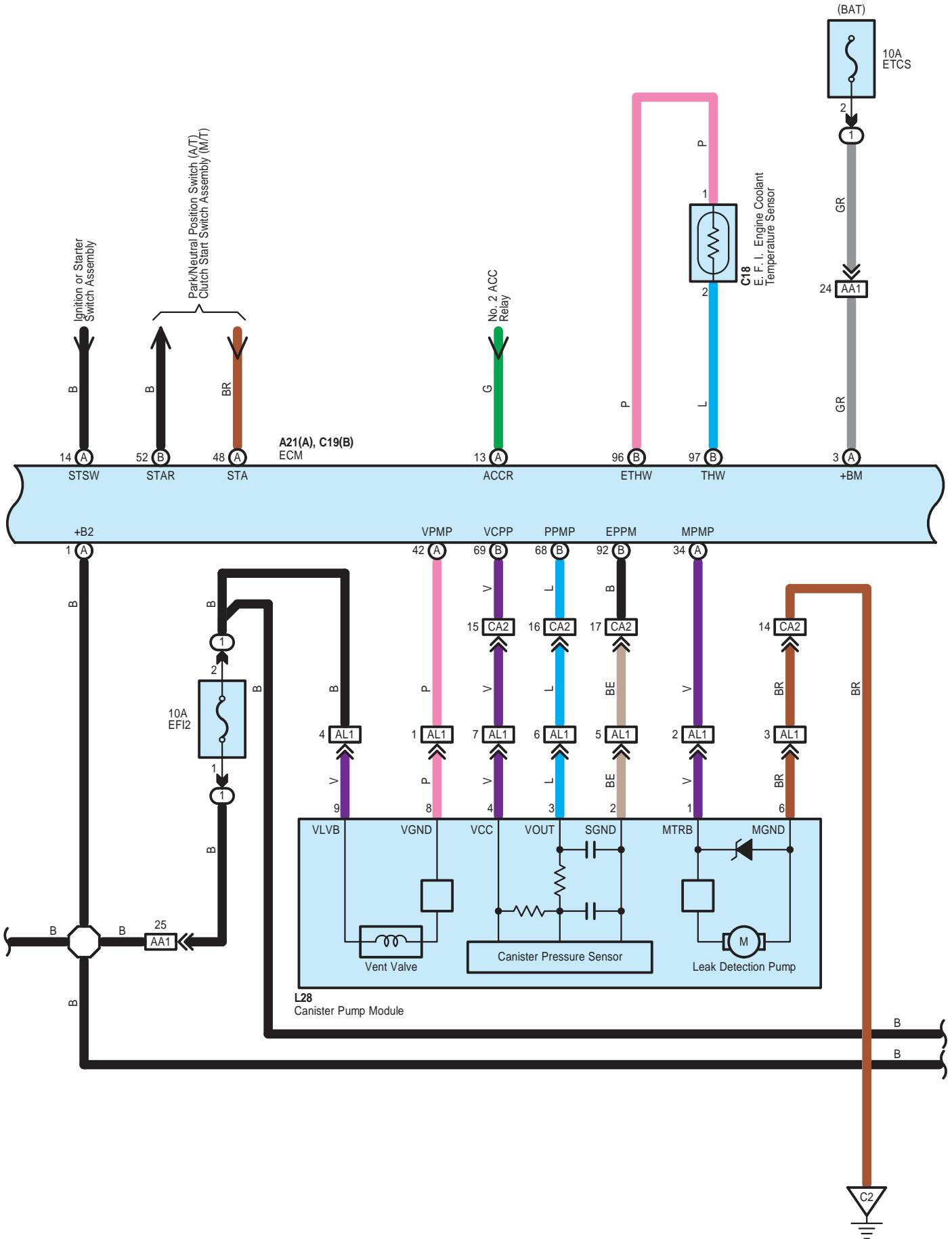

Engine Control

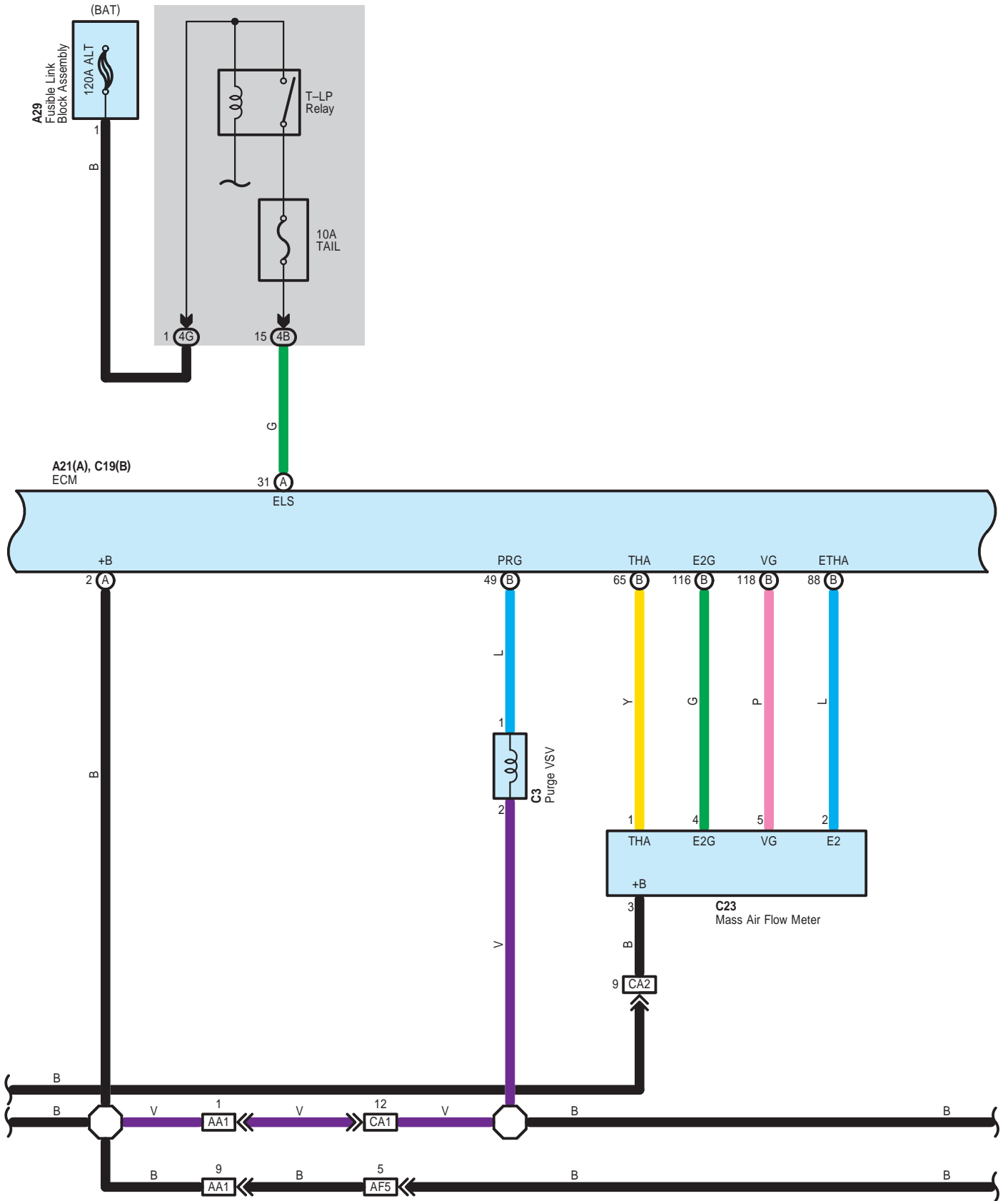

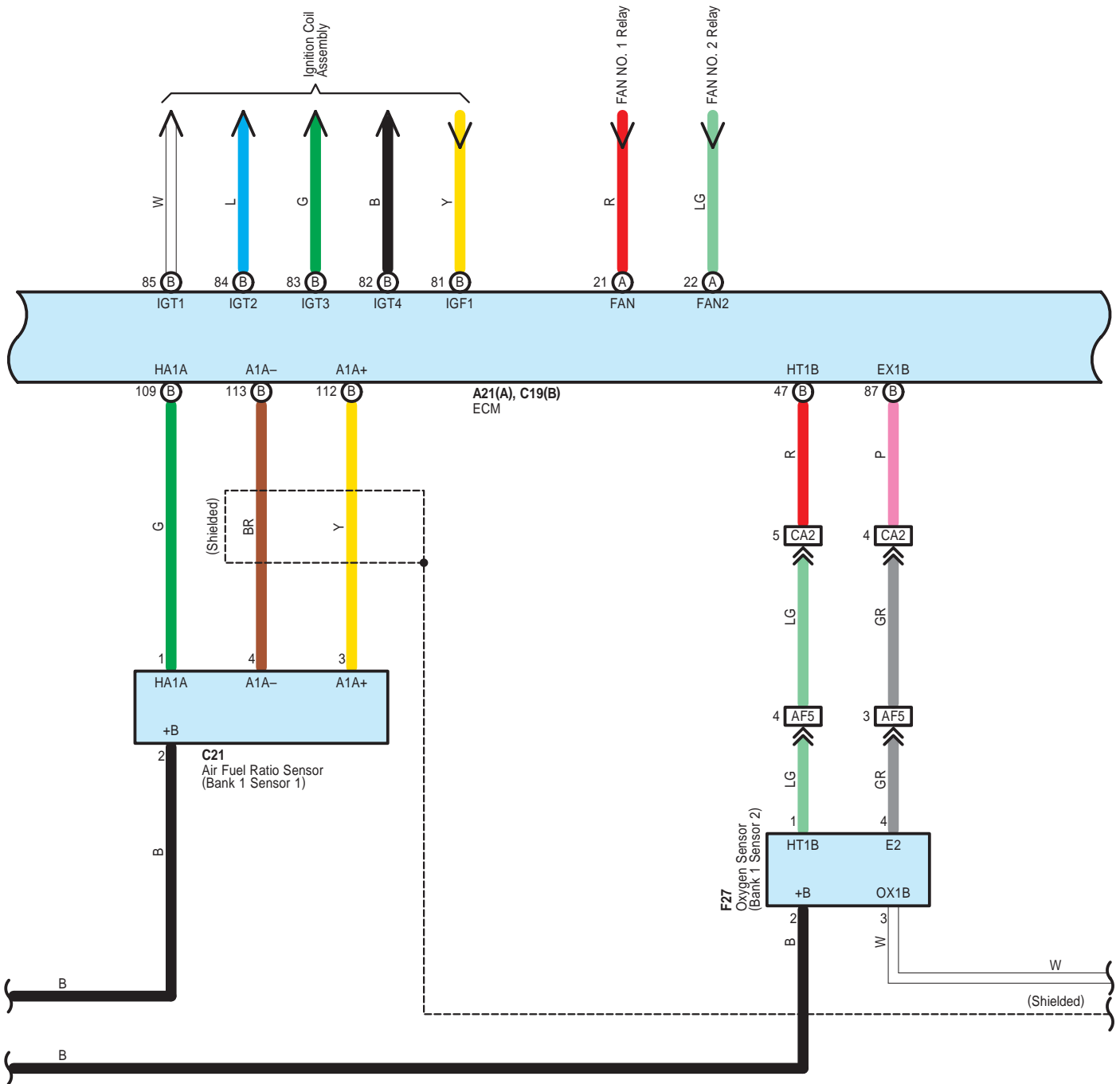

Engine Control

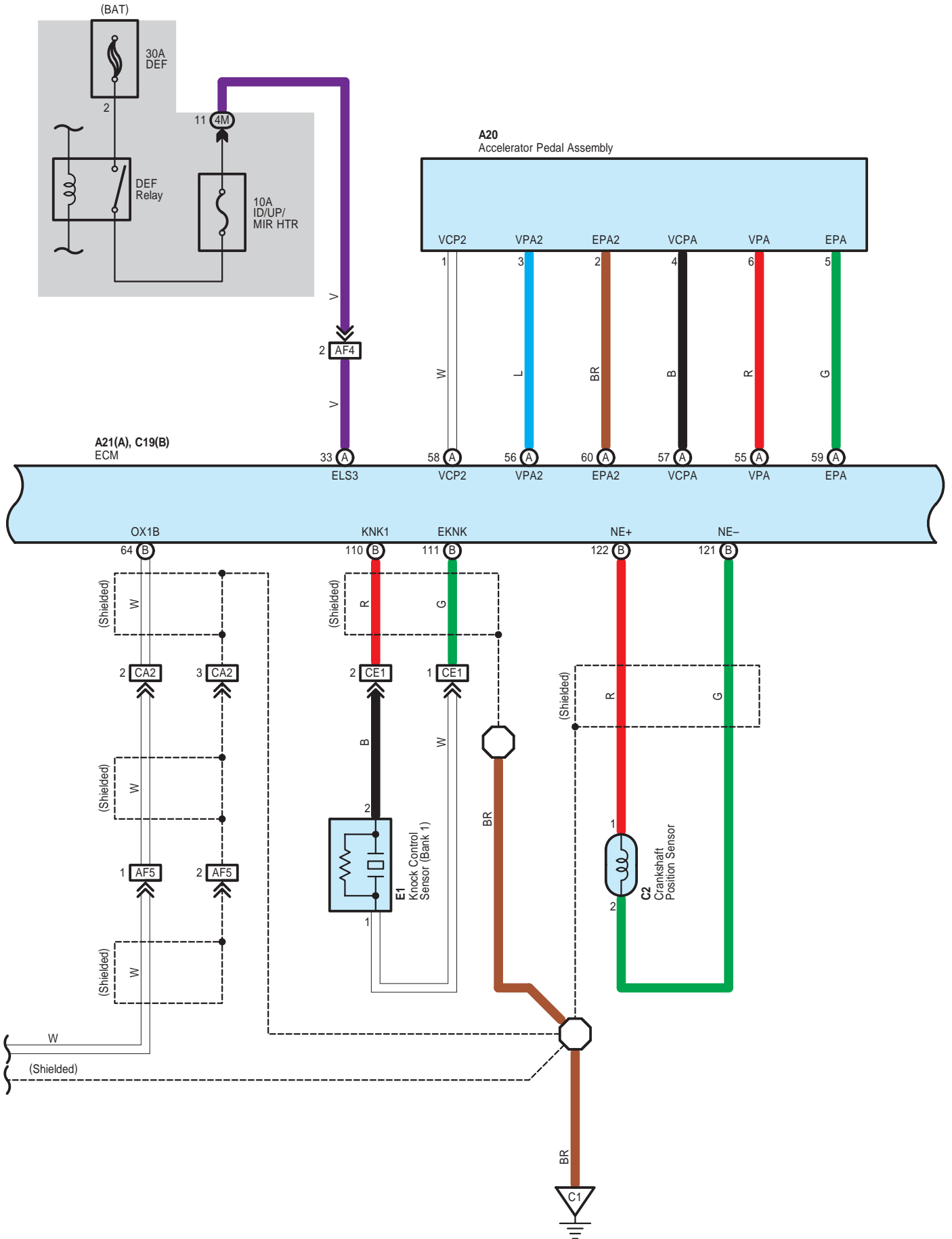

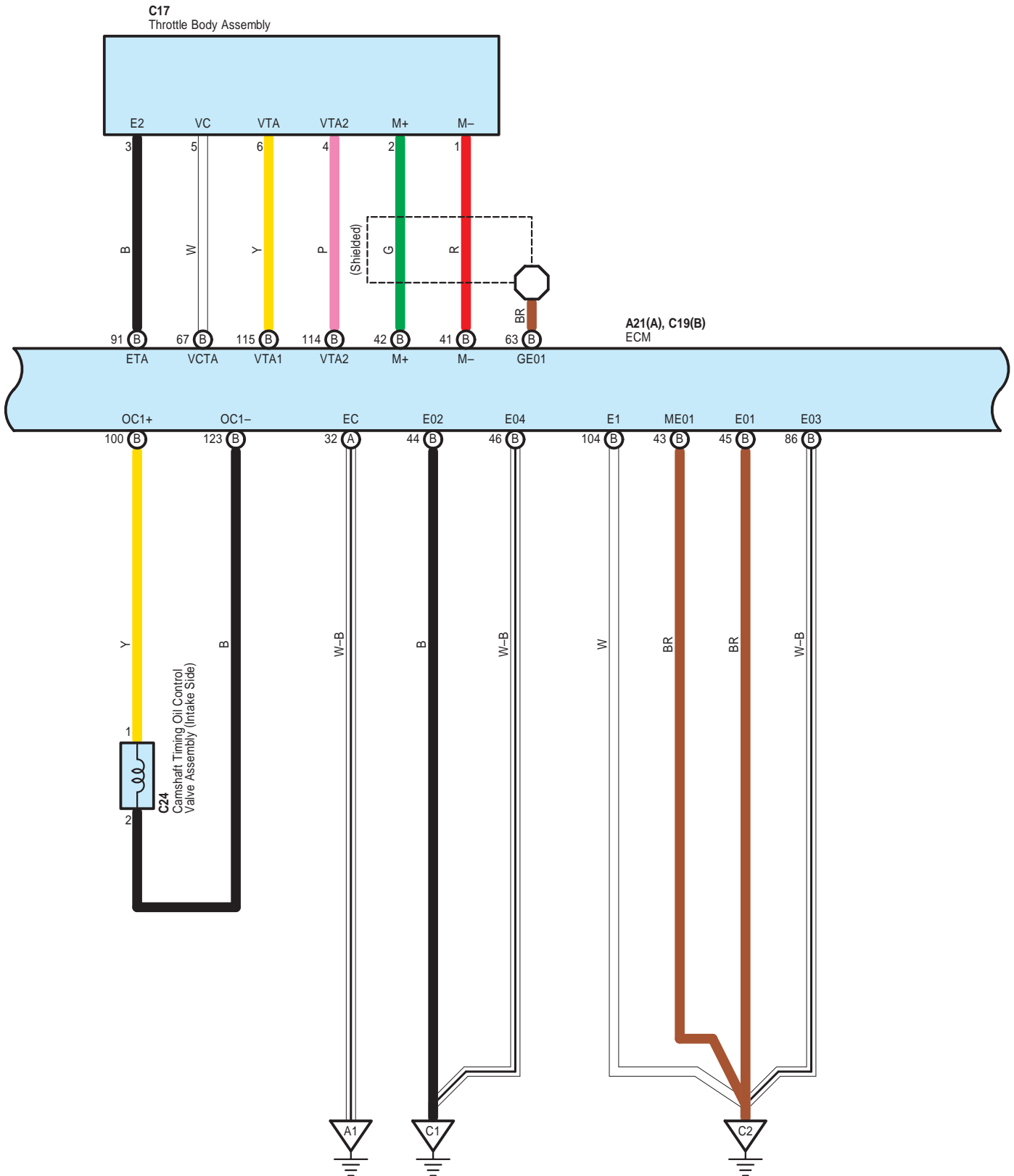

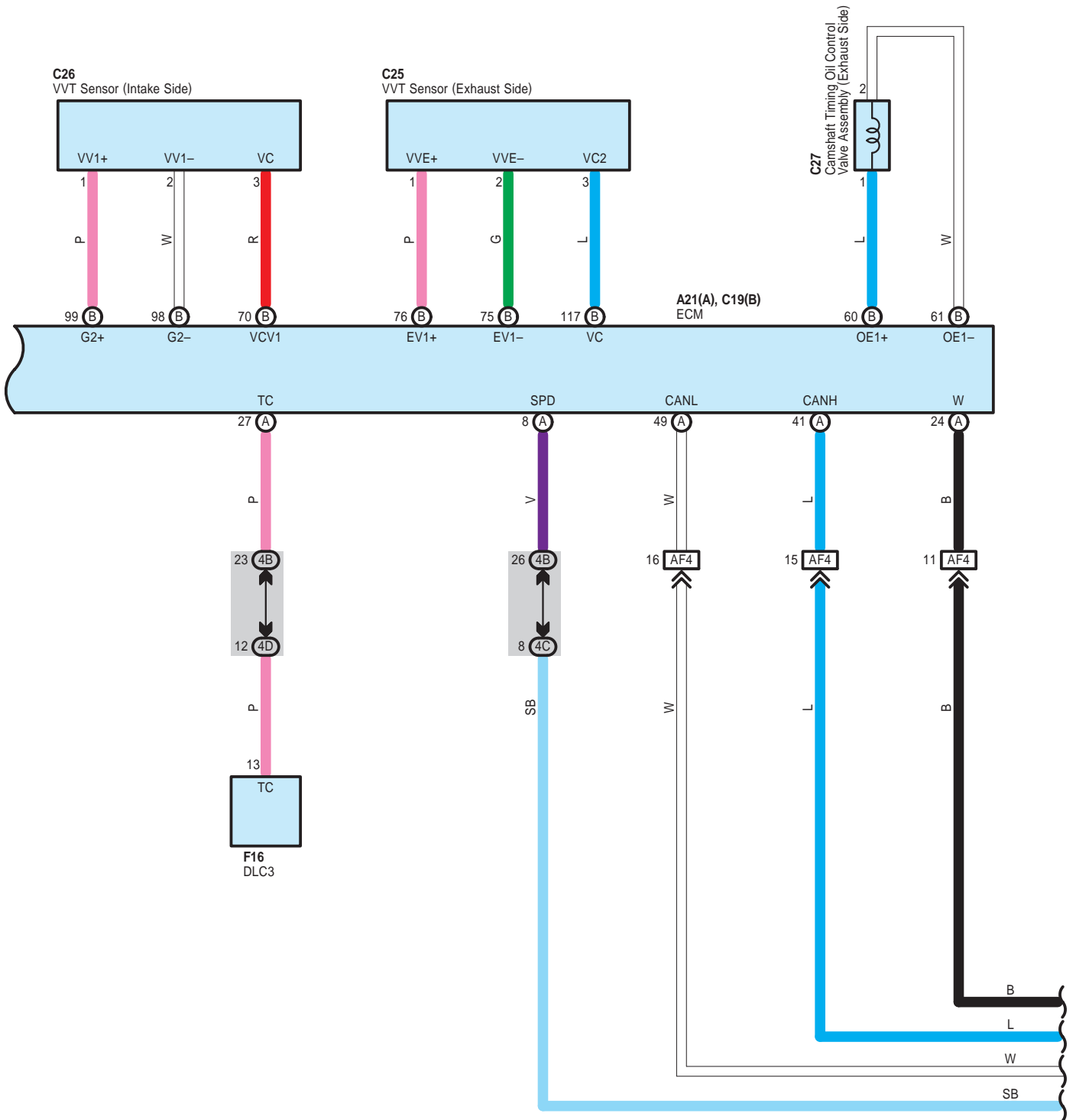

Engine Control

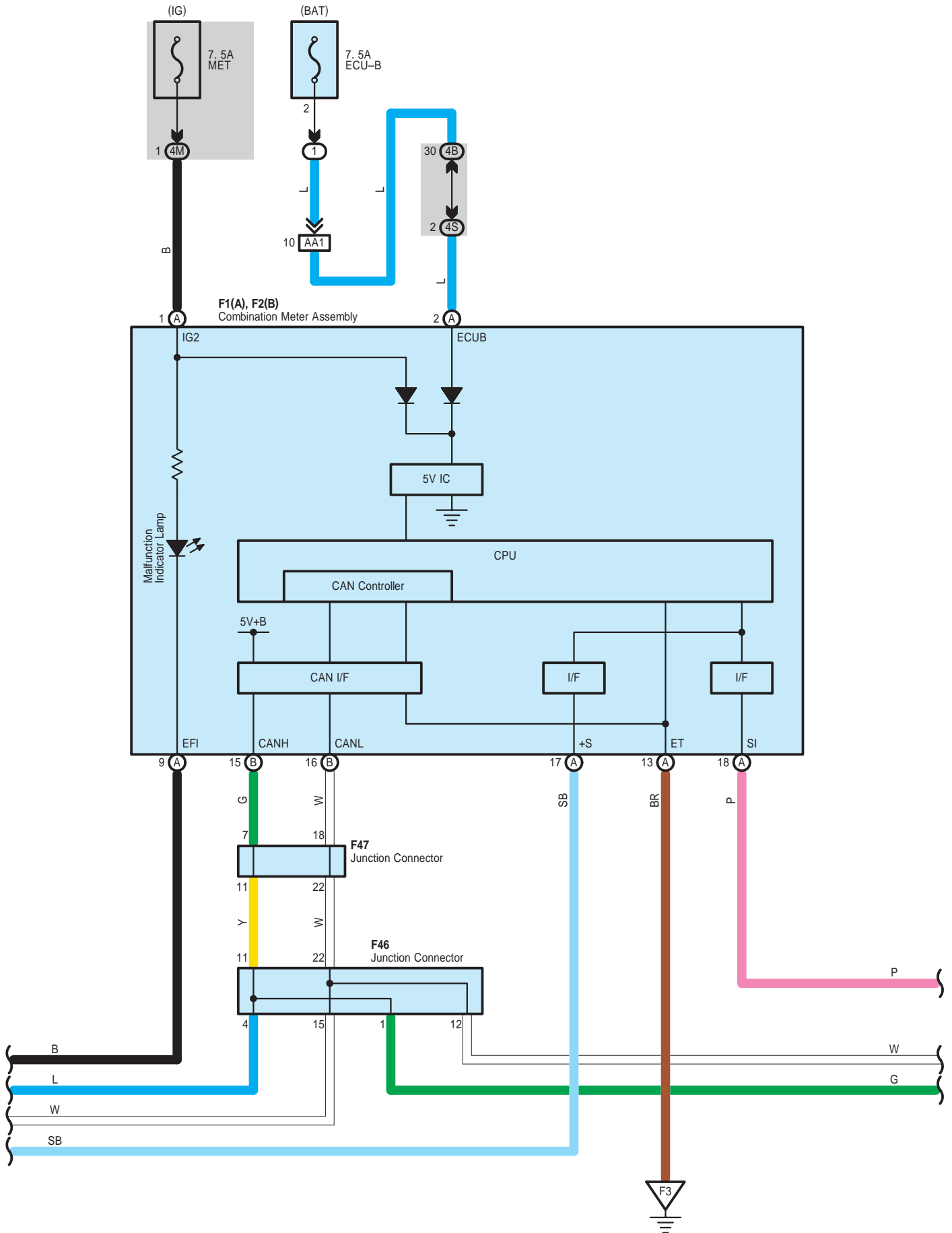

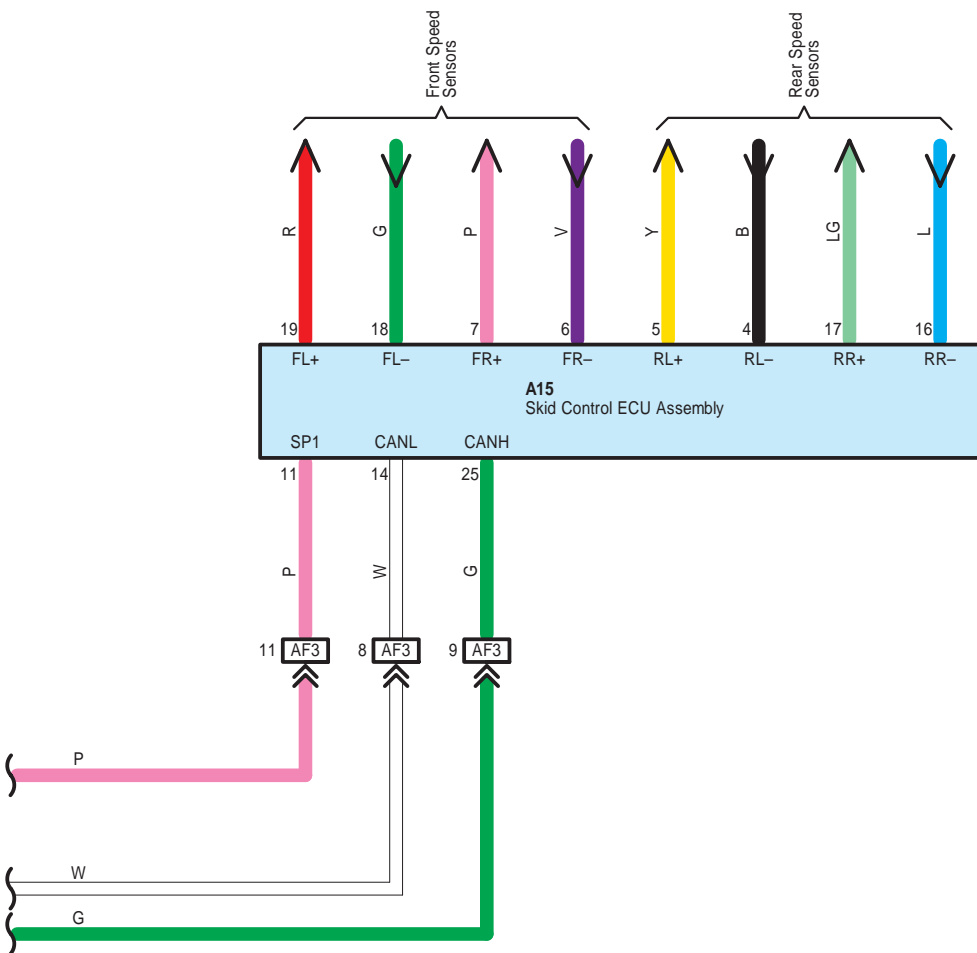

Engine Control

A 11

White

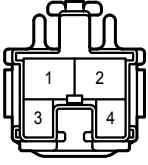

A 15

Black

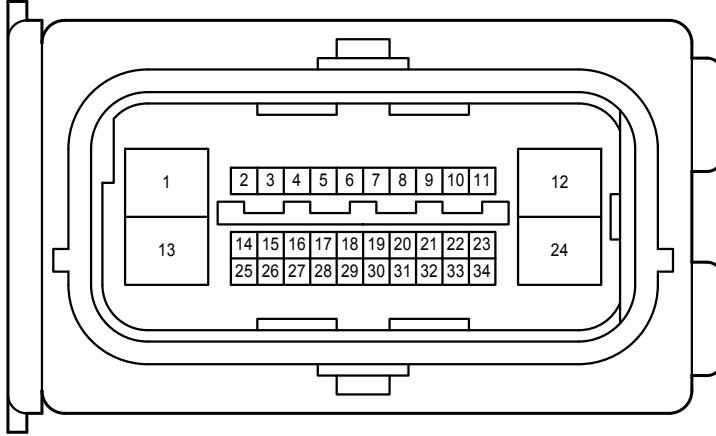

A 20

Black

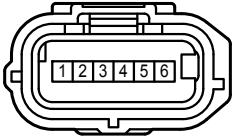

A 21

Black

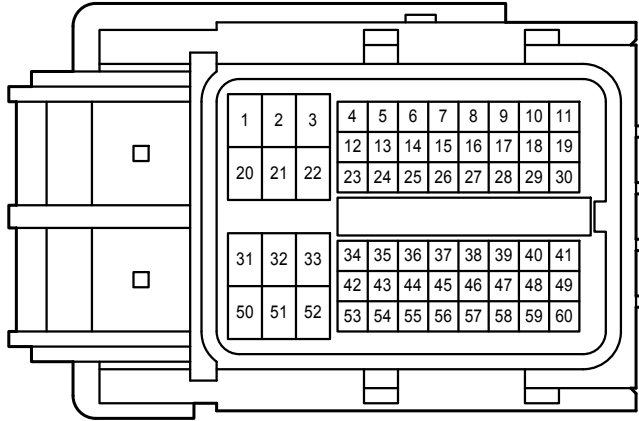

A 29

White



C 2

Black

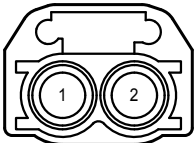

C 3

Blue

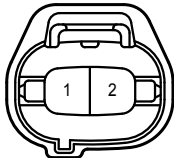

C 4

Black

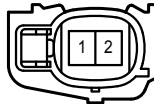

C 5

Gray

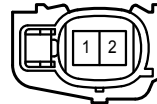

C 6

Black

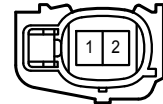

C 7

Gray

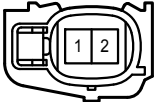

C 17

Black

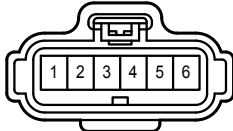

C 18

Black



C 19
Black

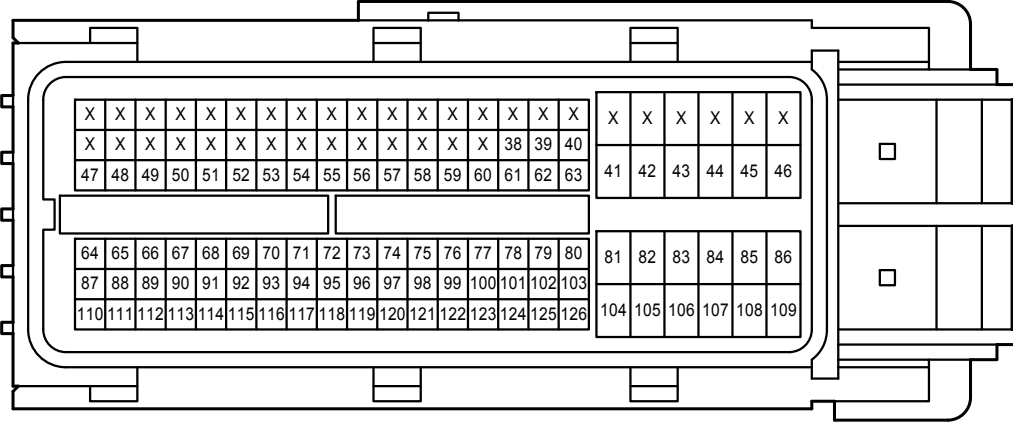

C 21
Dark Gray



C 23
Black

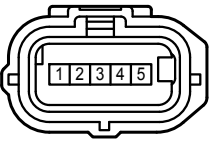

C 24
Gray



C 25
Black

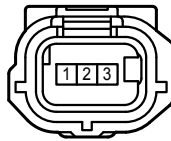

C 26
Gray

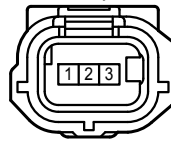

C 27
Black



E 1
Black

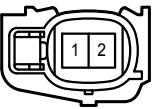

F 1
White

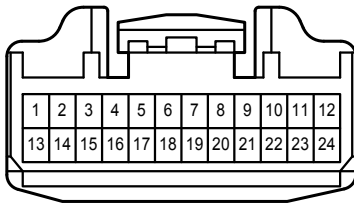

F 2
White

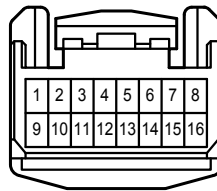

F 9
White

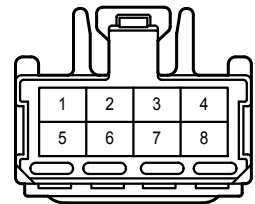

F 16
White

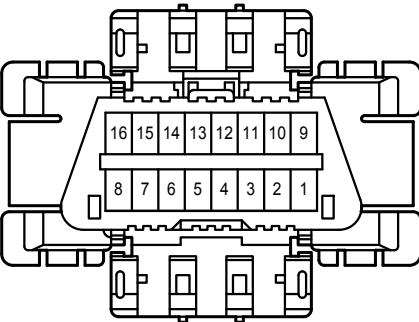

F 27
Dark Gray



F 46
White

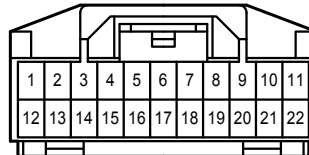

F 47
White

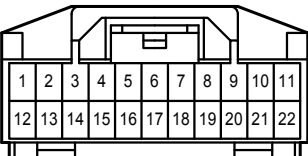

L 7
White



L 28
Black



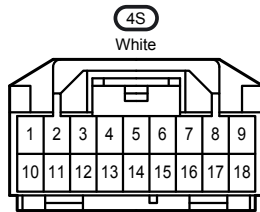
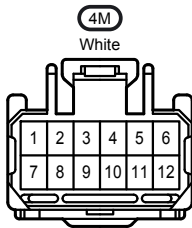
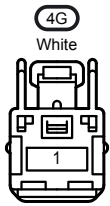
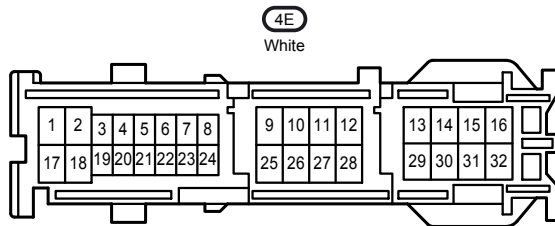
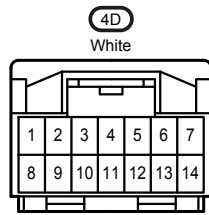
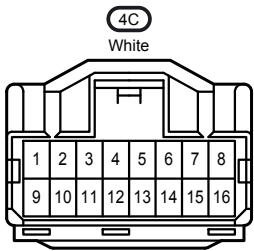
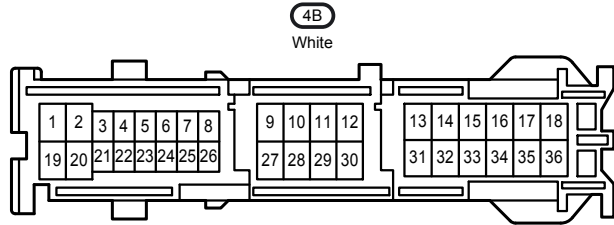
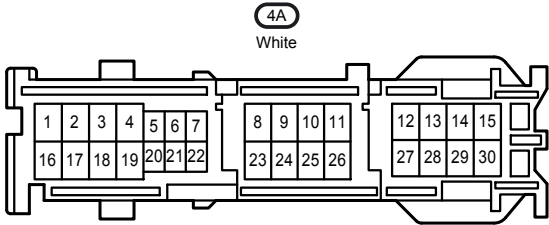
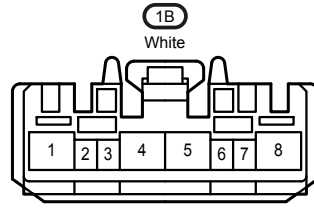
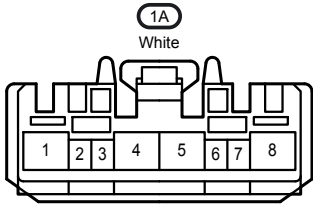

AA1
White

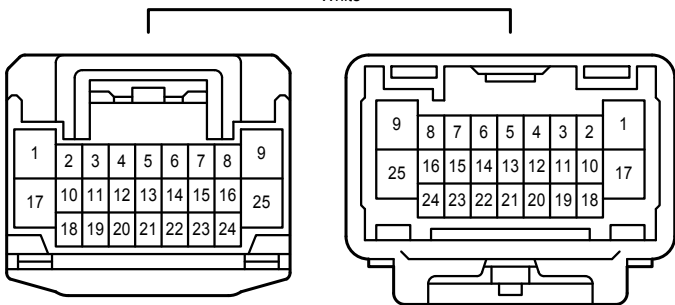

AF2
White

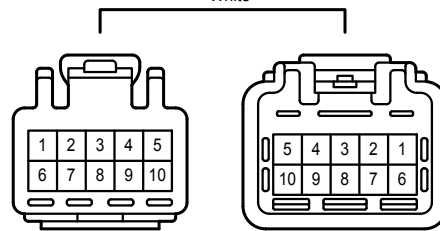

AF3
Black

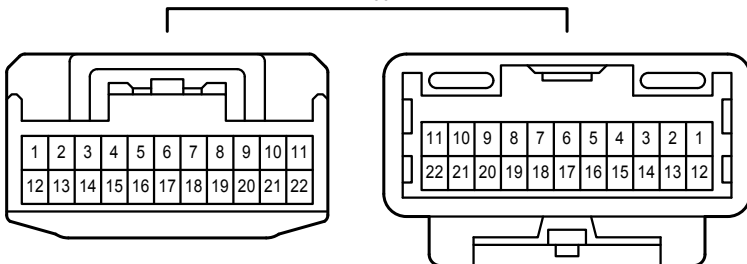

AF4
Gray

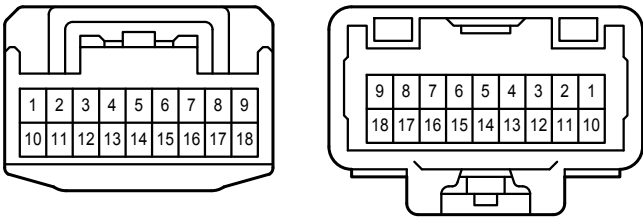

AF5
Blue

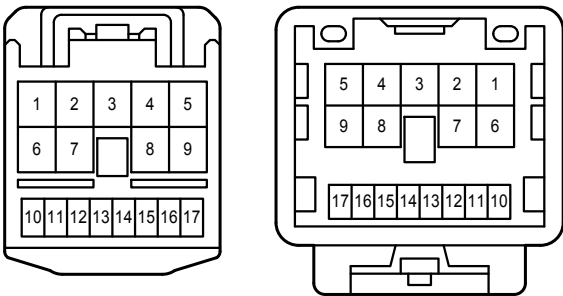

AL1
White

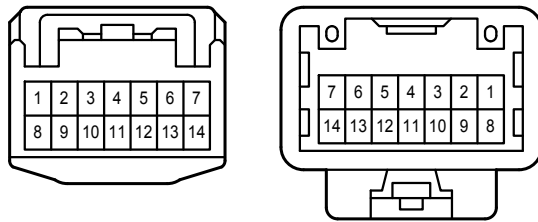

CA1
White

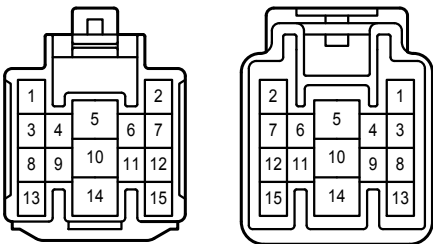

CA2
White

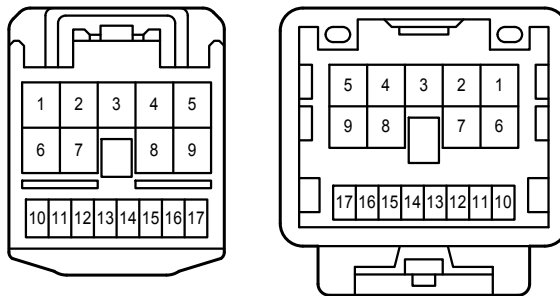

CE1
Gray

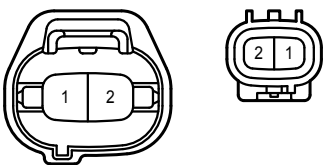

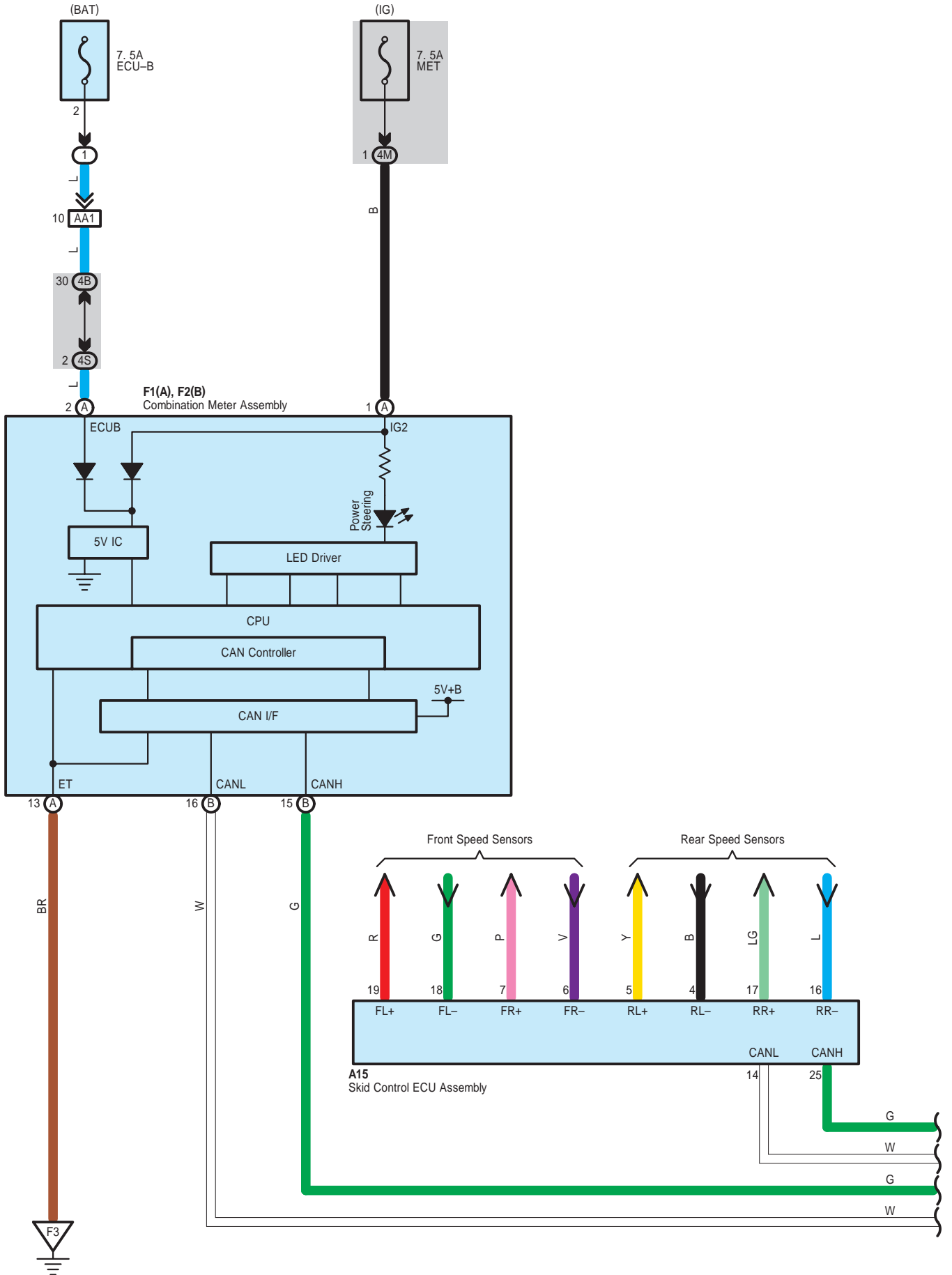

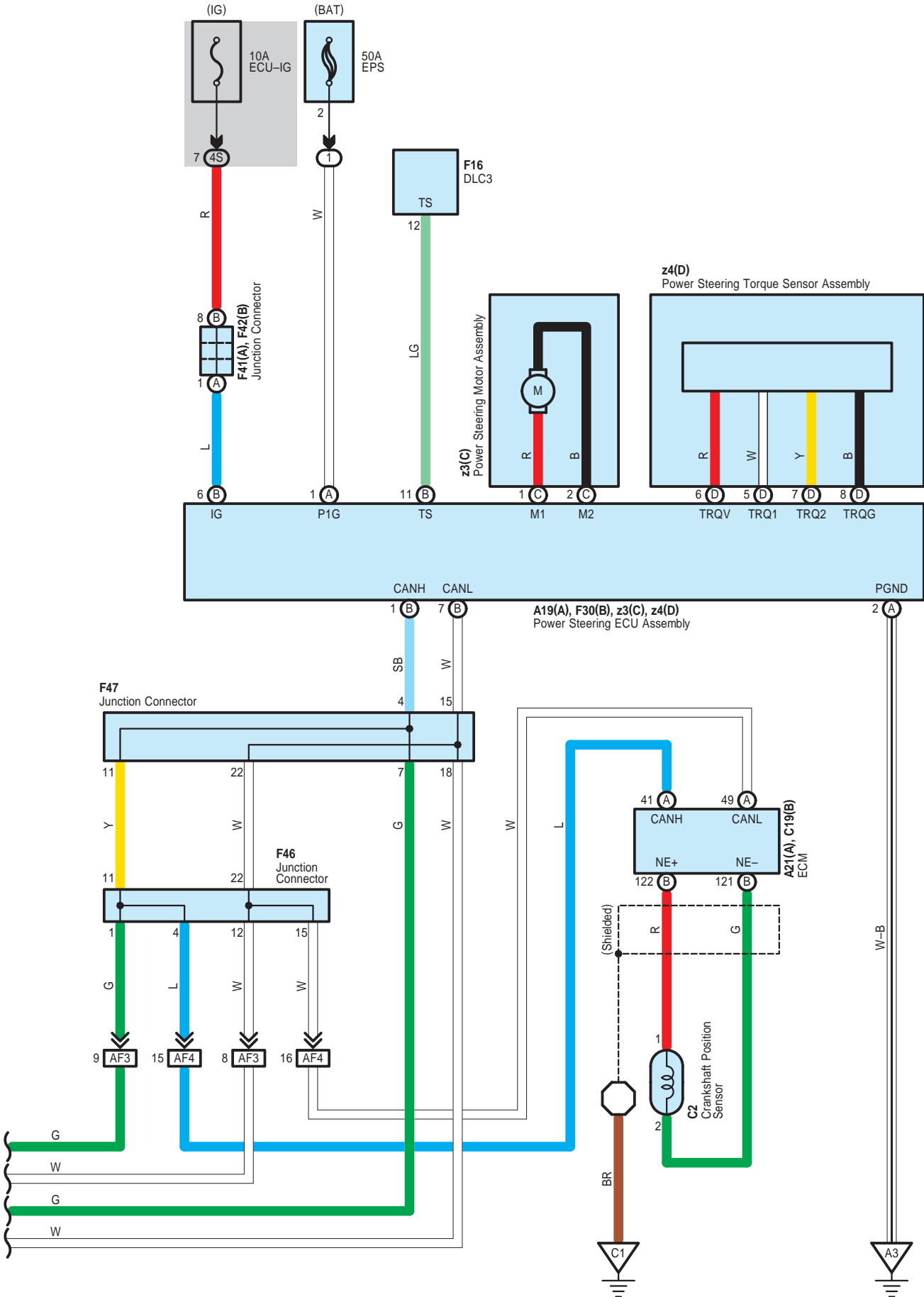

A 15
Black

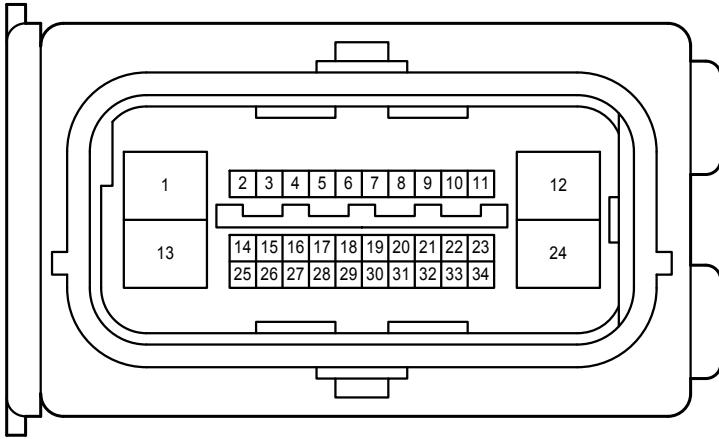

A 19
Gray

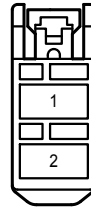

A 21
Black

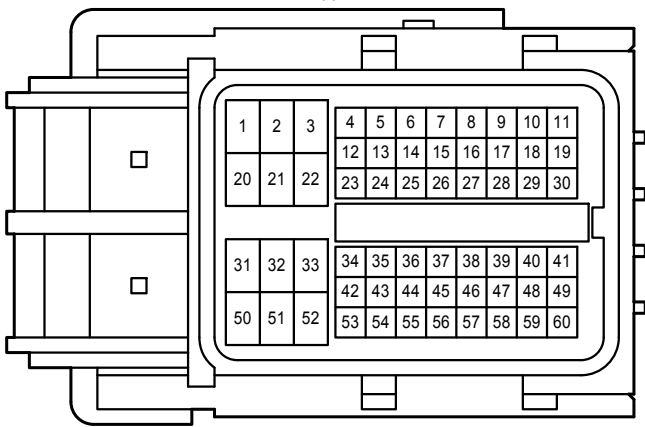

C 2
Black

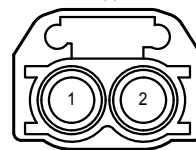

C 19
Black

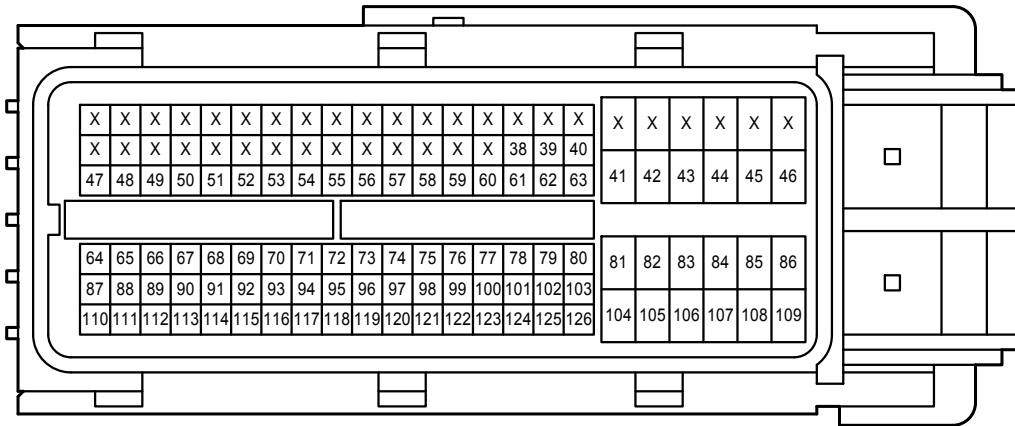

F 1
White

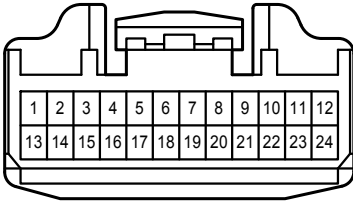

F 2
White

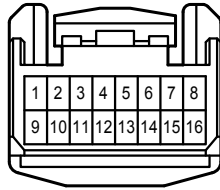

F 16
White

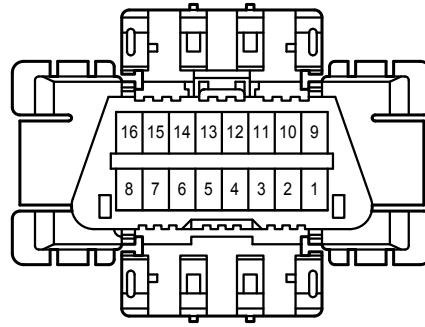

F 30
White

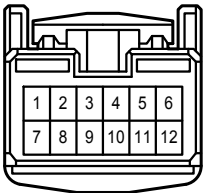

F 41
White

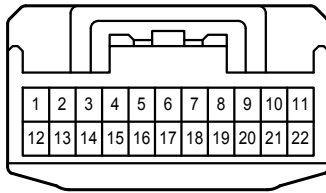

F 42
White

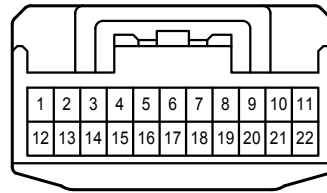

F 46
White

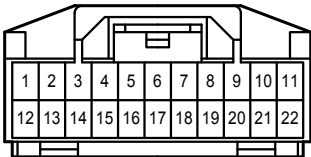

F 47
White

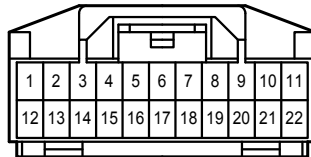

z 3
White



z 4
White

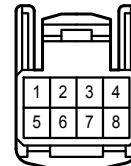

4B
White

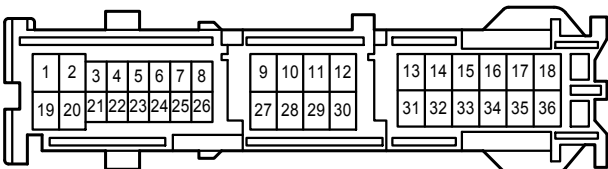

4M
White

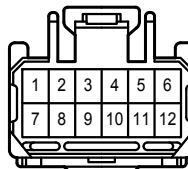

4S
White

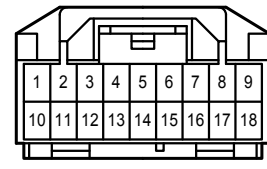

AA1
White

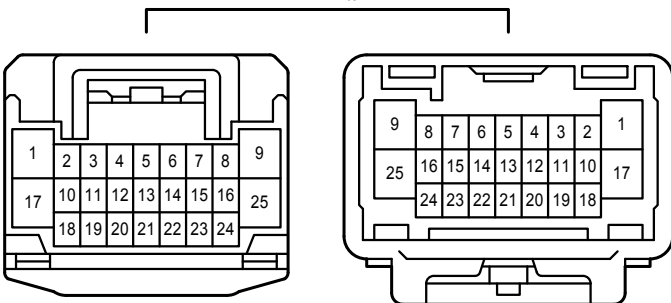

AF3
Black

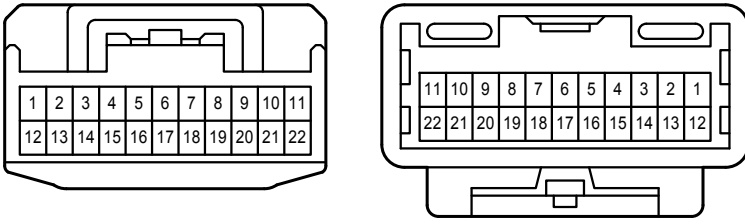

AF4
Gray

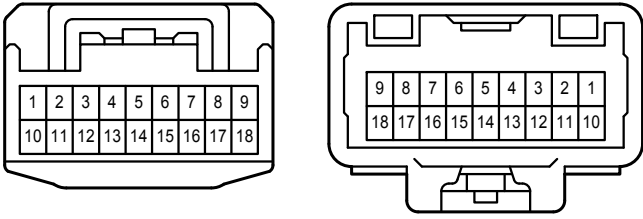

F RELAY LOCATIONS

<p>① : Engine Room R/B Assembly</p> <p>○ : Engine Room J/B Assembly</p>	<h2>Front Fender Apron LH (See Page 20)</h2>
---	--

- * 1:H-LP LH/H-LP LO LH
- * 2:H-LP RH/H-LP LO RH
- * 3:30A HTR SUB1 (for High Current)
- * 4:30A RDI (for High Current)
- * 5:40A HTR (for High Current)
- * 6:50A ABS1/VSC1 (for High Current)
- * 7:50A EPS (for High Current)
- * 8:40A HTR SUB2 (for High Current)
- * 9:FAN NO.2 Relay
- * 10:ST Relay

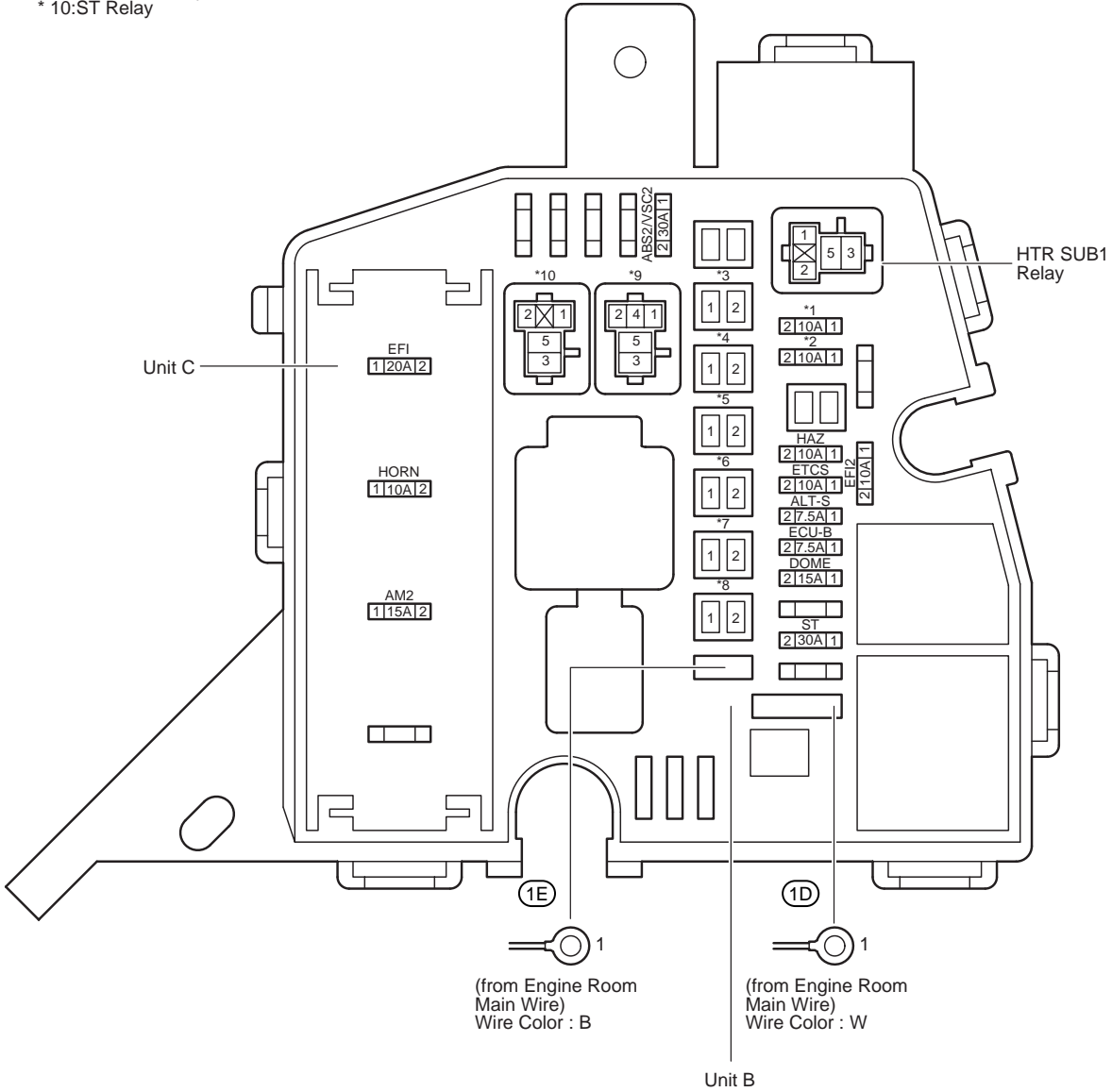

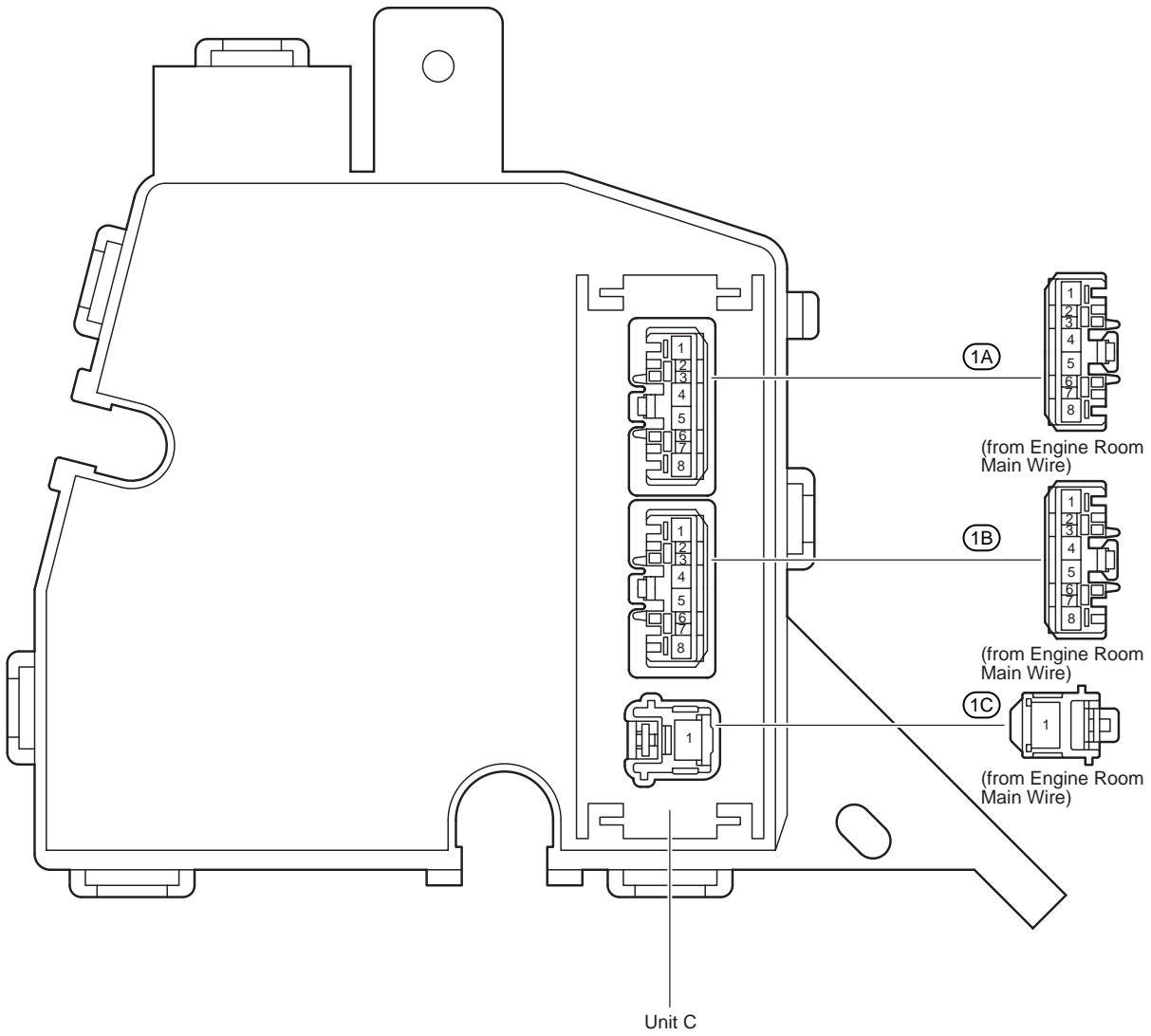

F RELAY LOCATIONS

 : Instrument Panel J/B Assembly **Lower Finish Panel (See Page 20)**

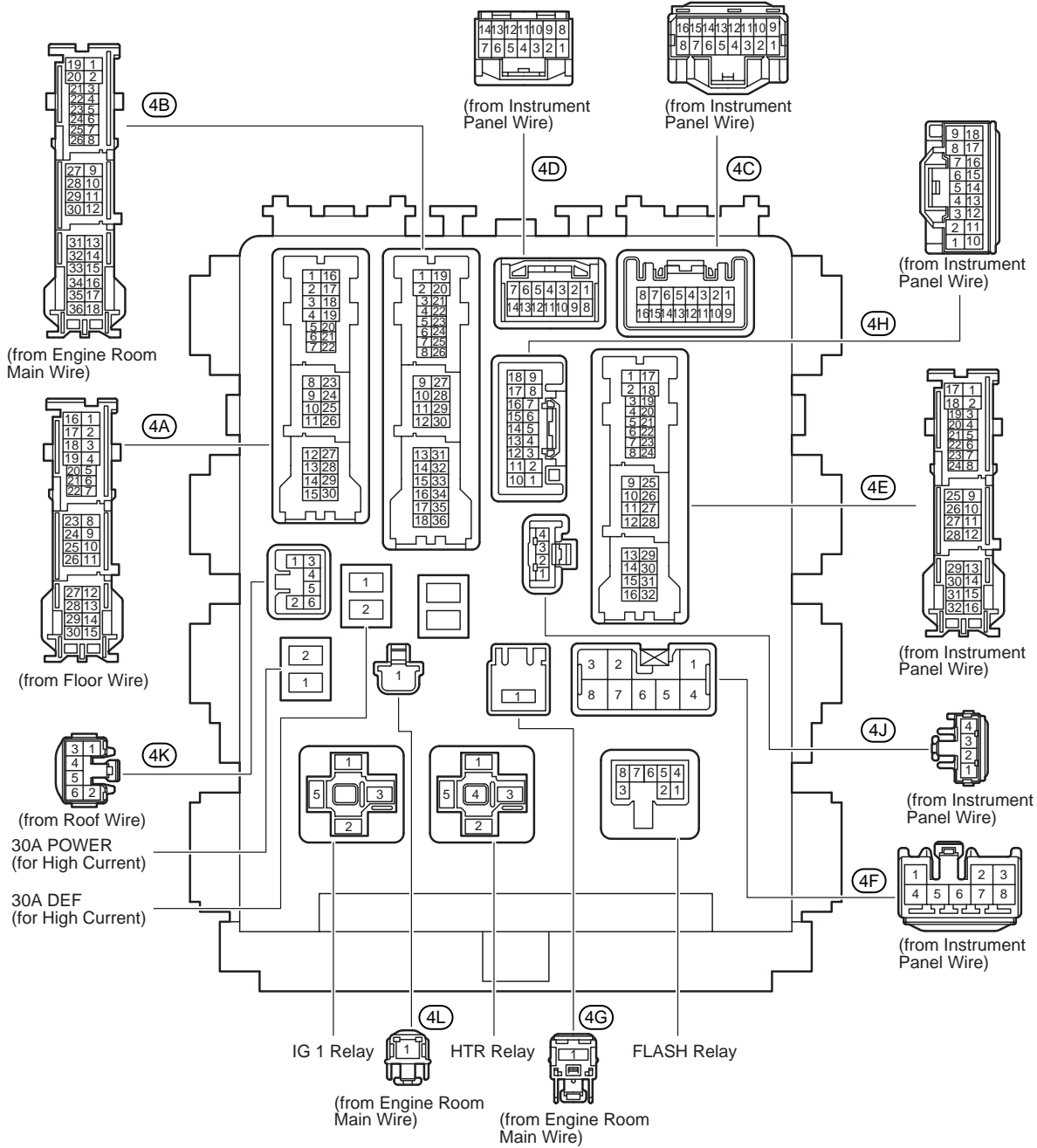

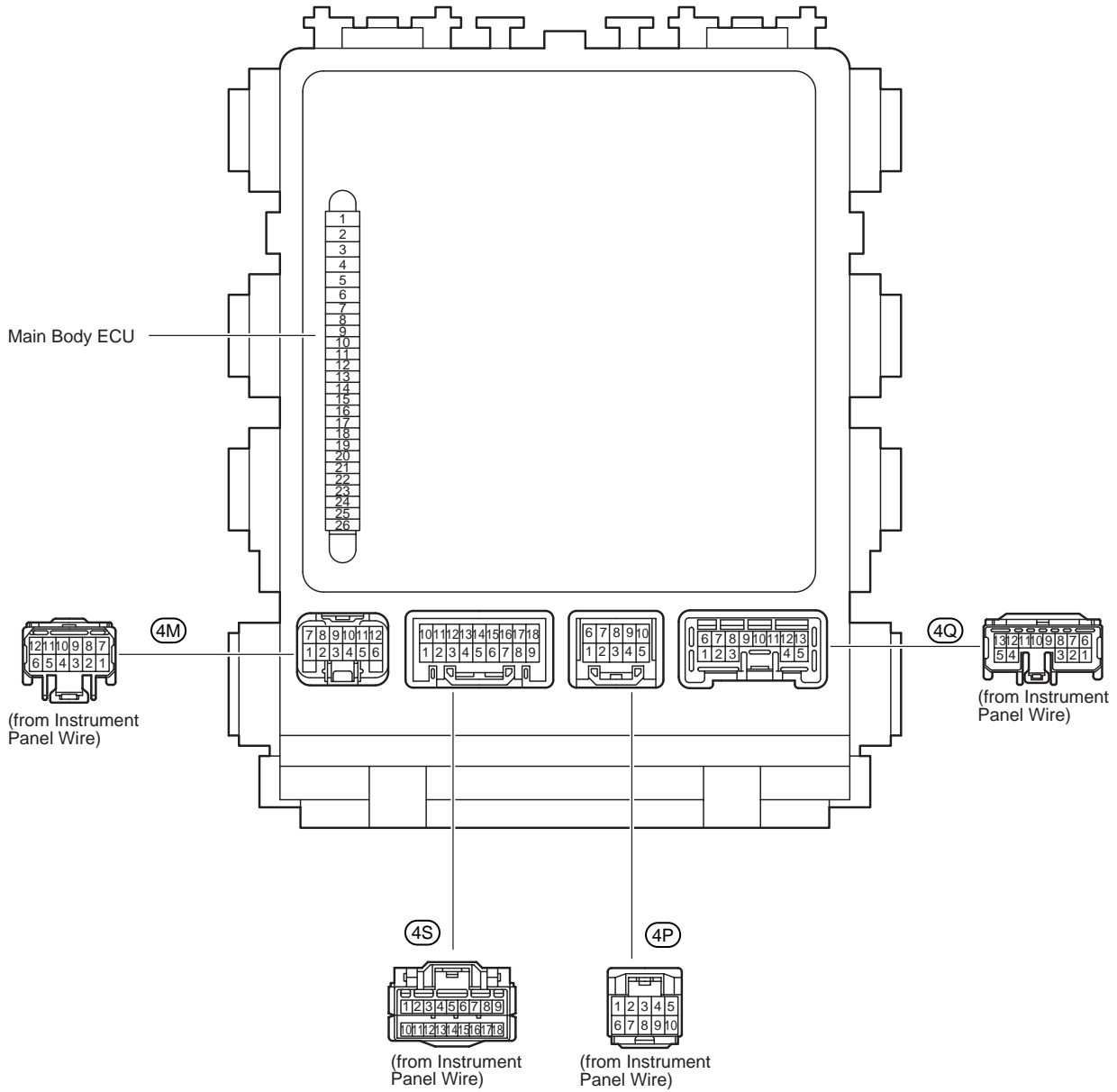

F RELAY LOCATIONS

 : Instrument Panel J/B Assembly **Lower Finish Panel (See Page 20)**

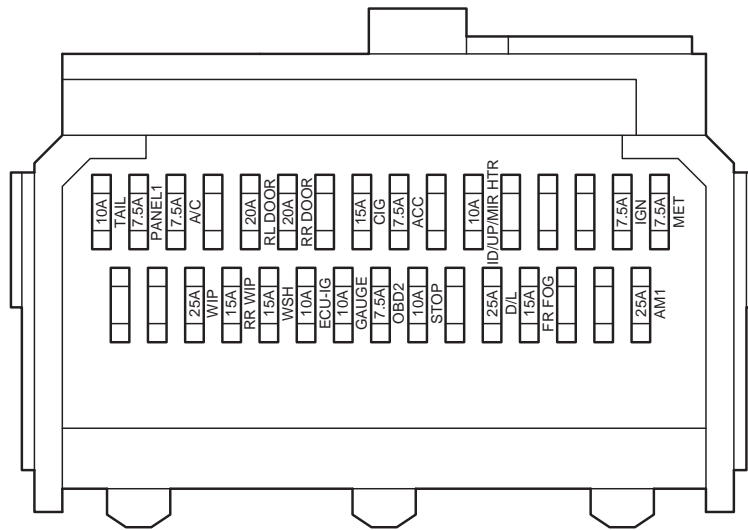

Front Wiper and Washer

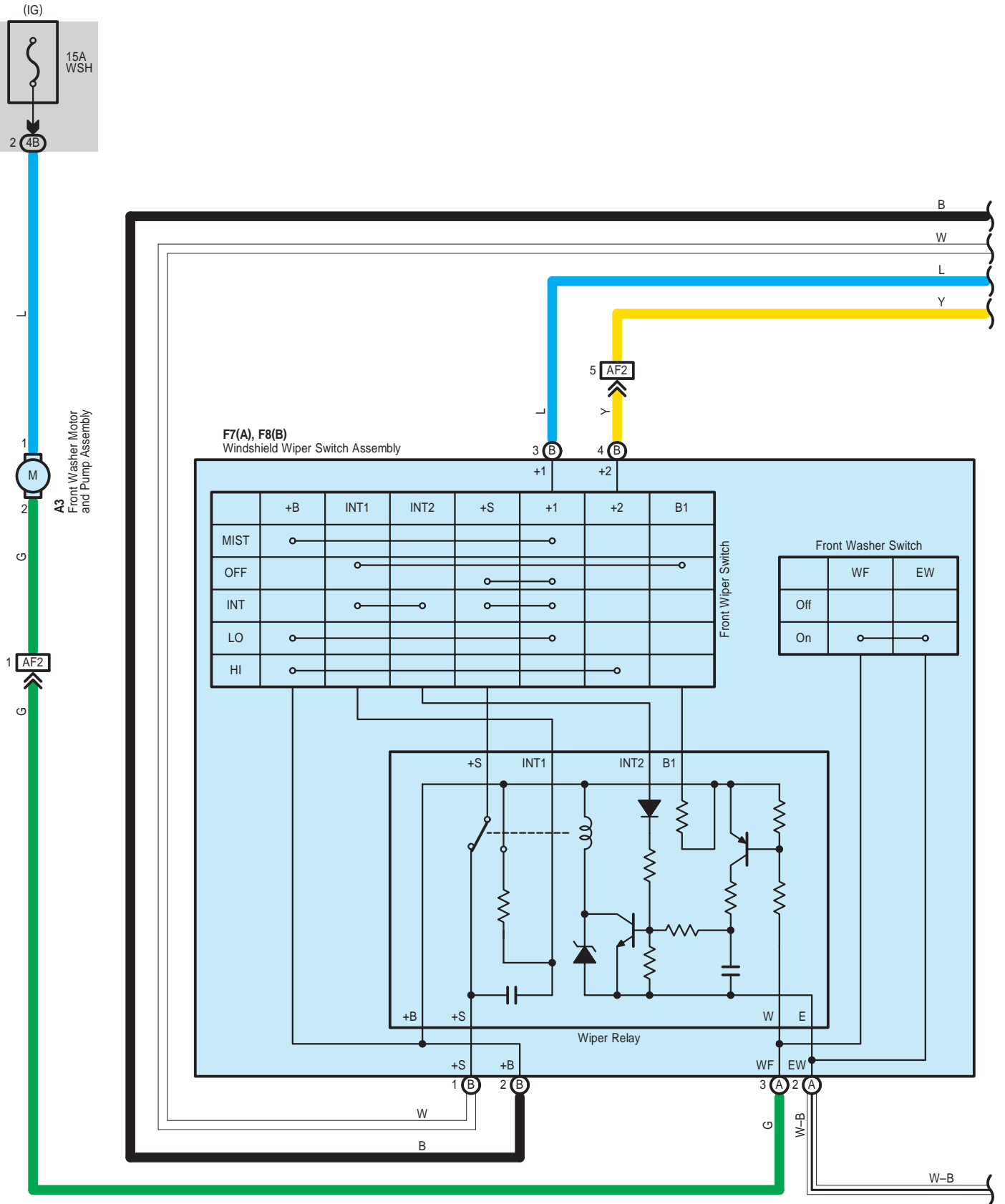

Front Wiper and Washer

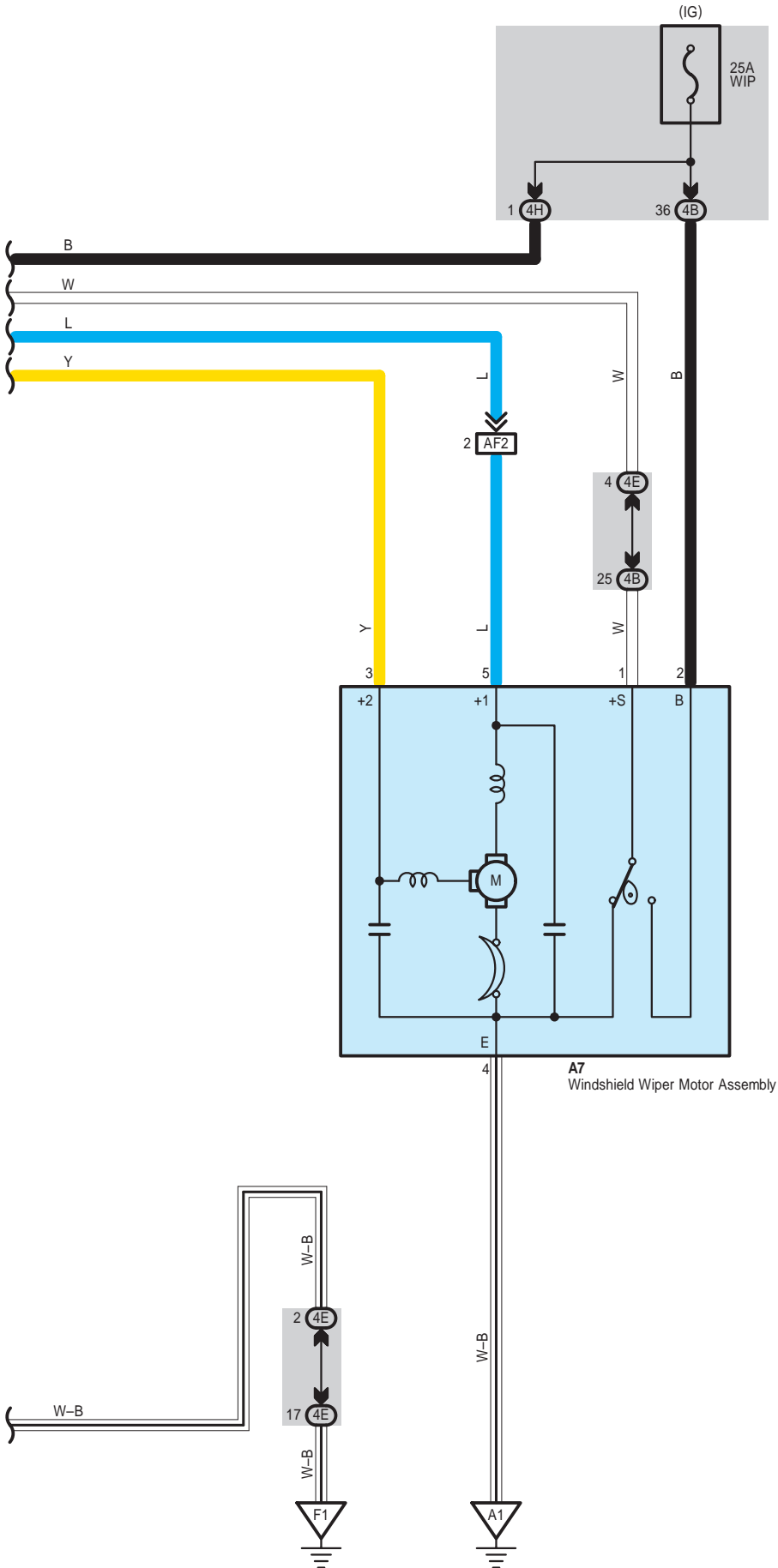

Front Wiper and Washer

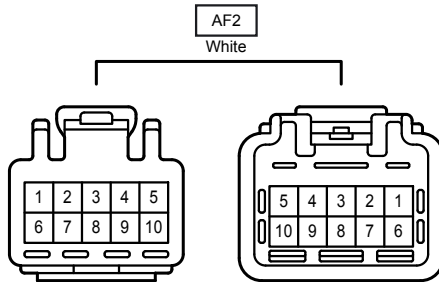
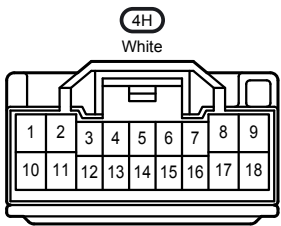
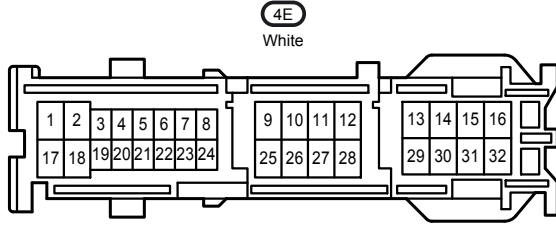
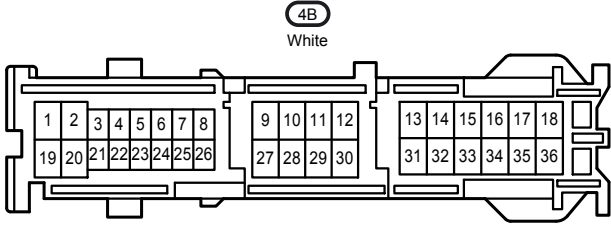
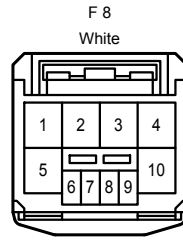
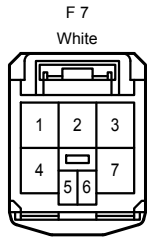
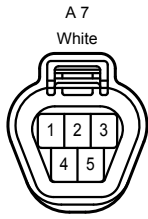
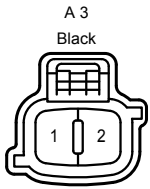

Ground Point

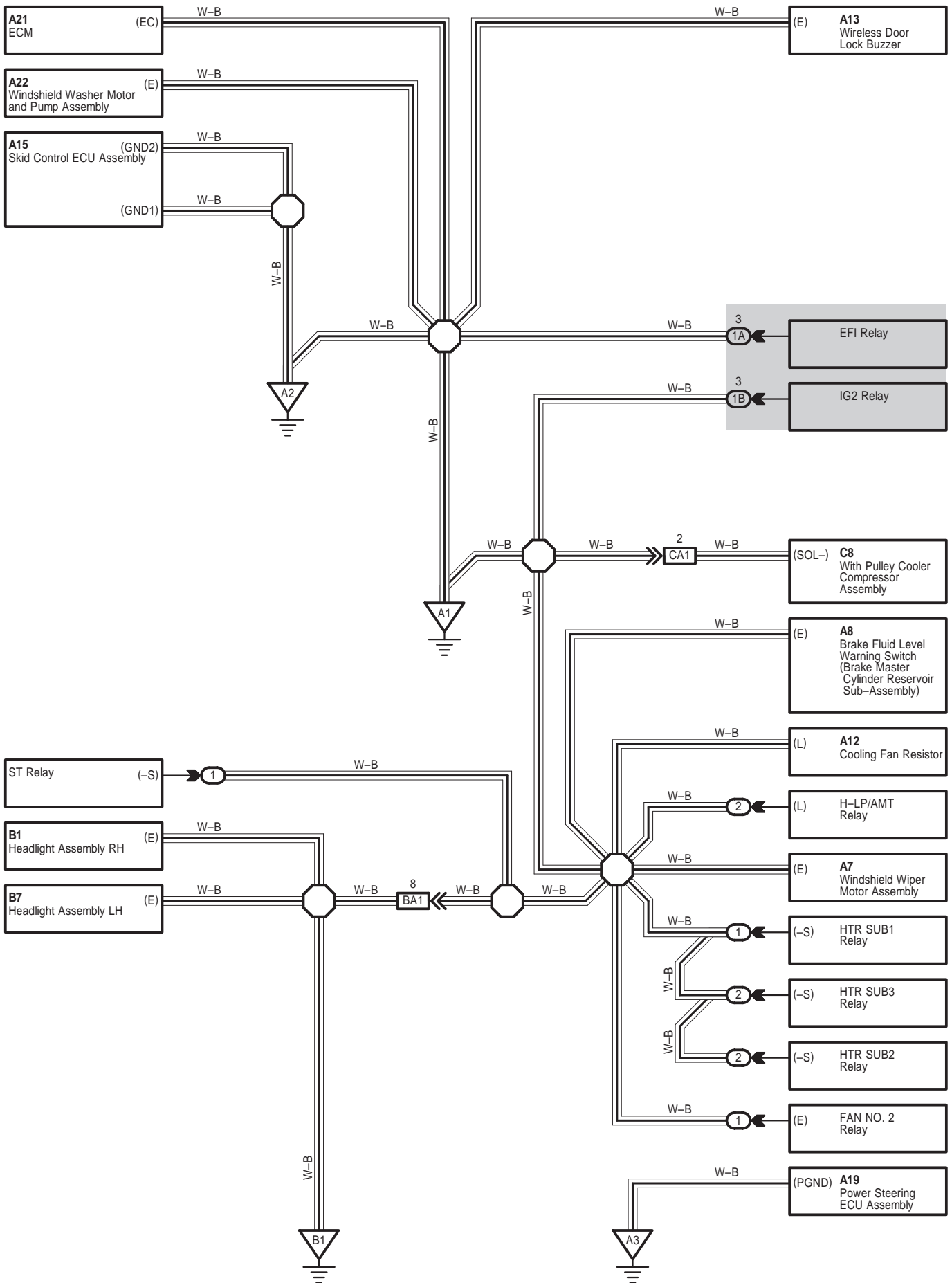

Ground Point

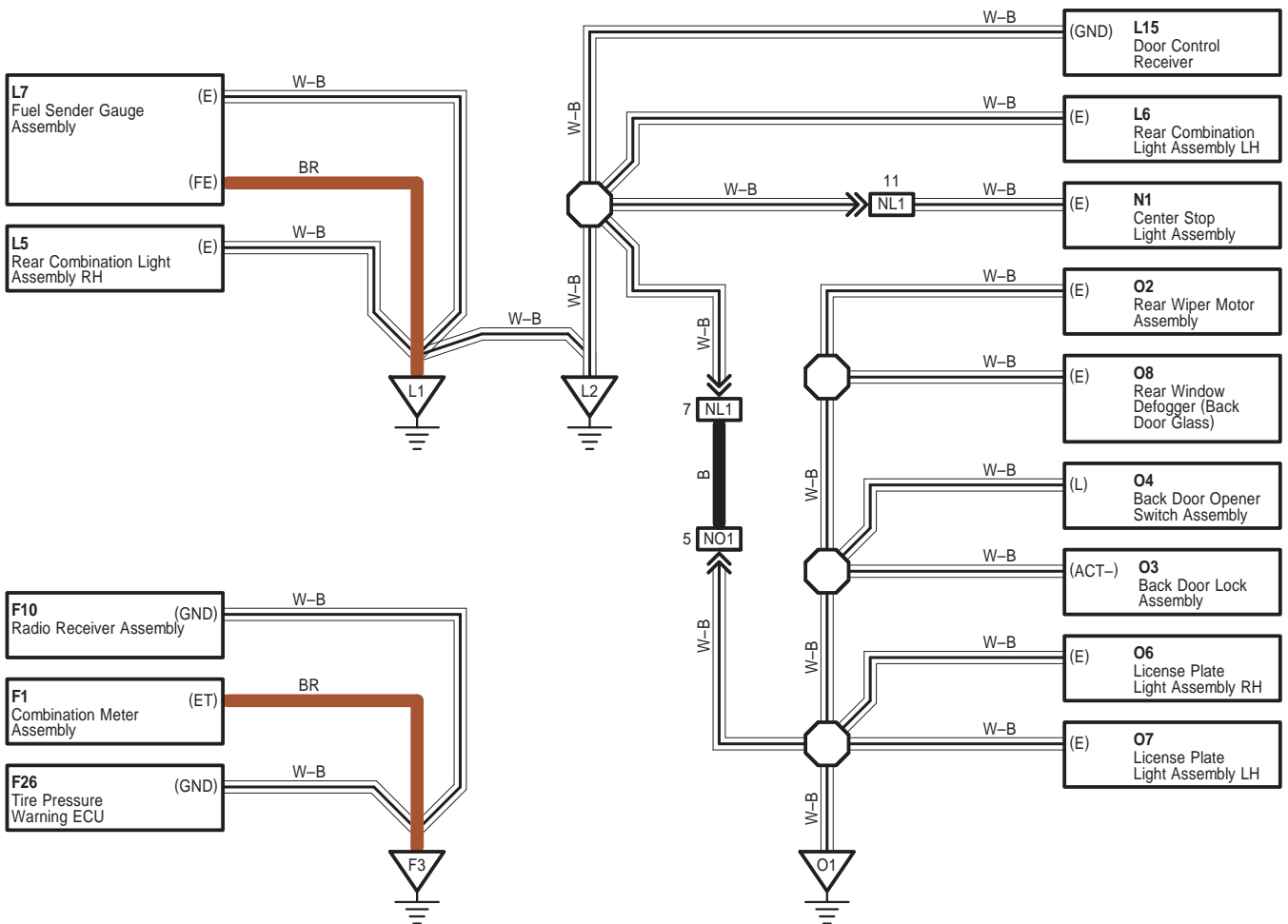
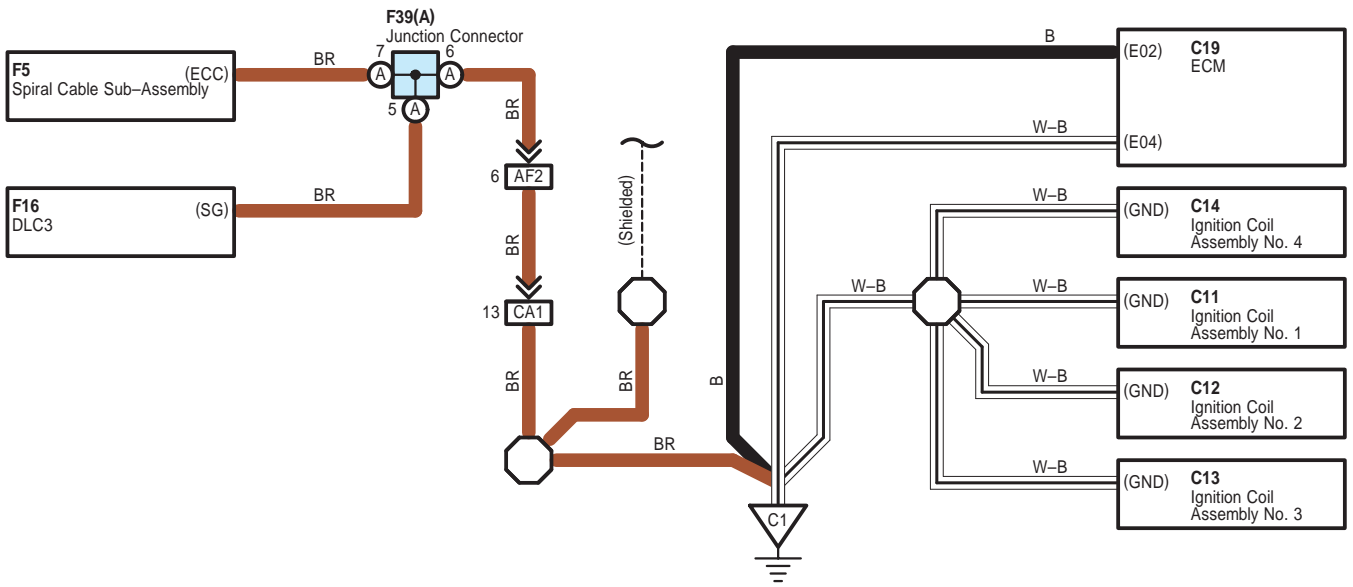

Ground Point

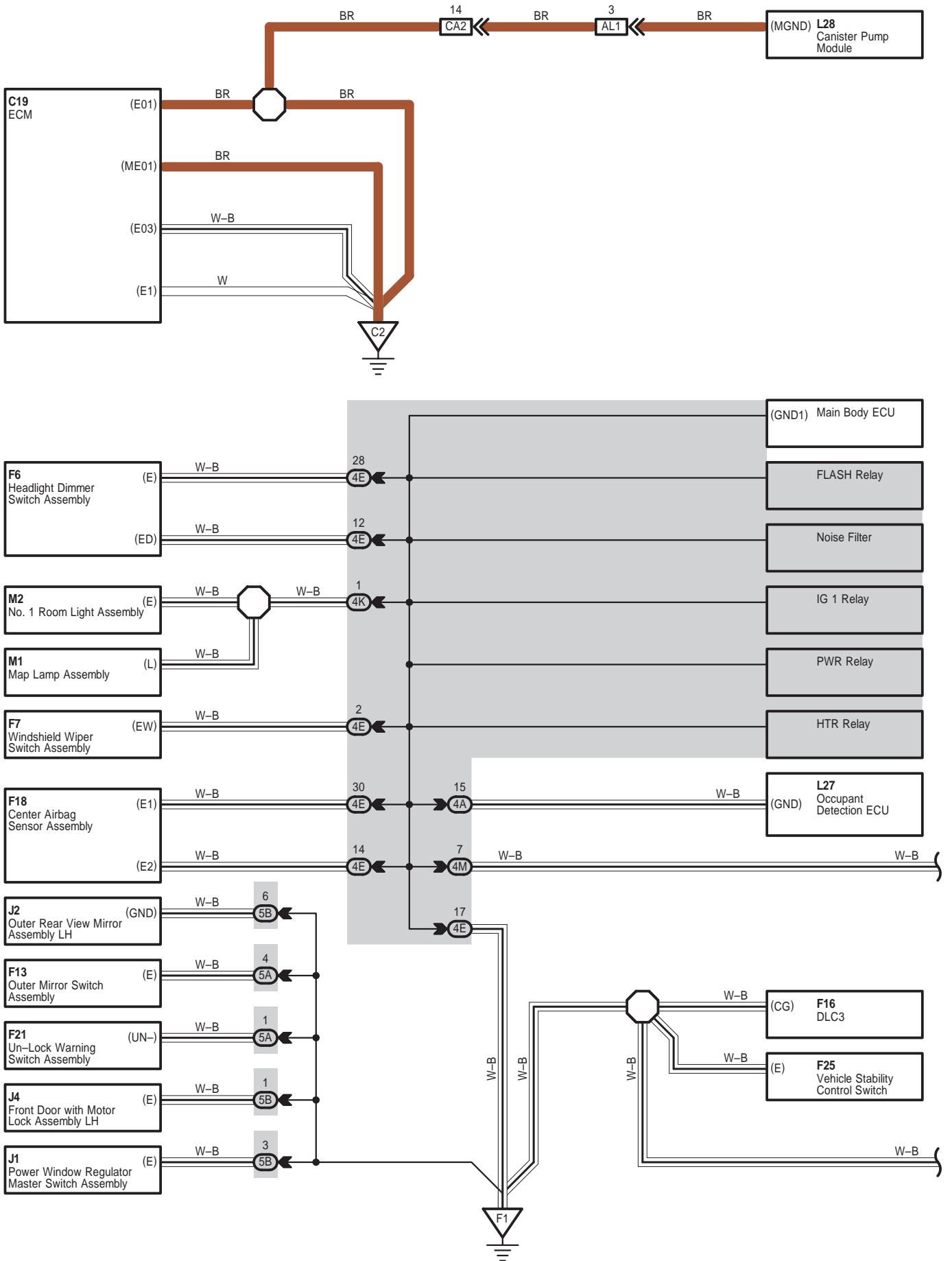

Ground Point

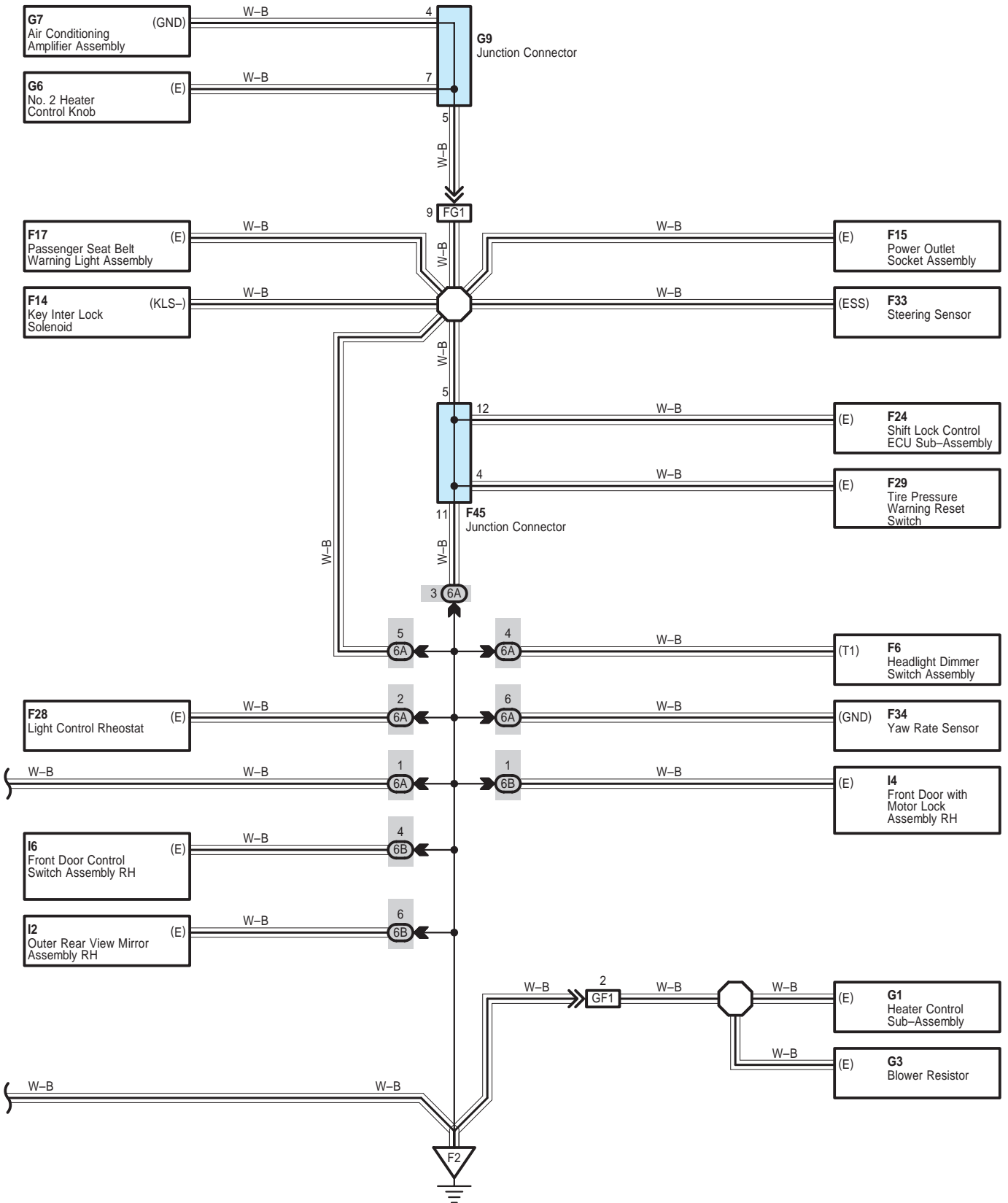

F 39
White

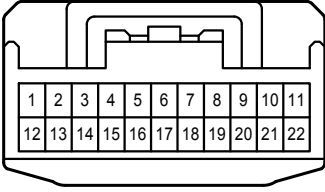

F 45
White

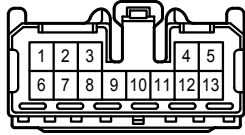

G 9
White

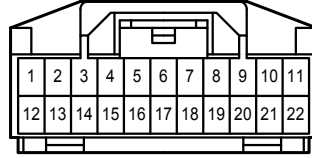

1A
White

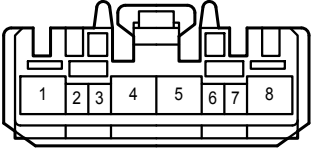

1B
White

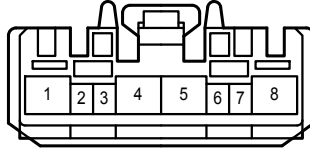

4A
White

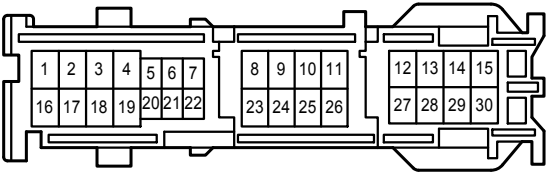

4E
White

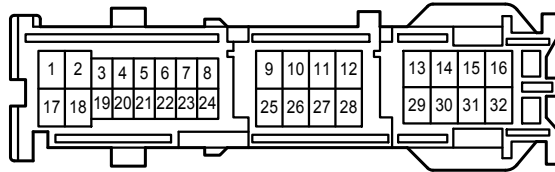

4K
White



4M
White

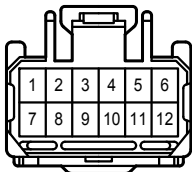

5A
White

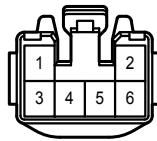

5B
White

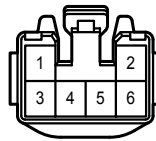

6A
White

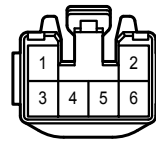

6B
White



AA1
White

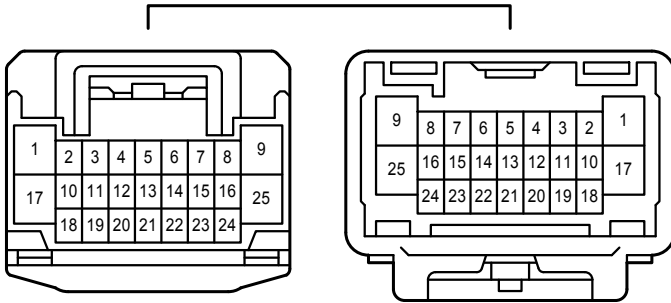

AF2
White

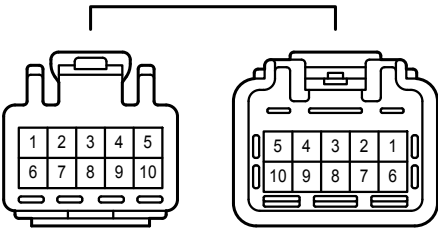

AL1
White

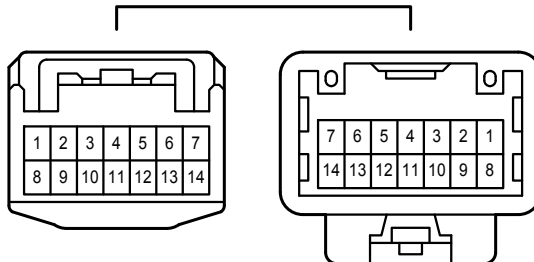

BA1
White

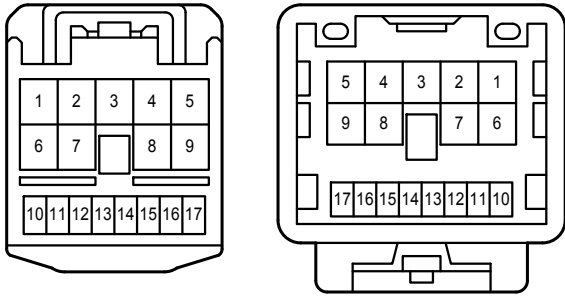

CA1
White

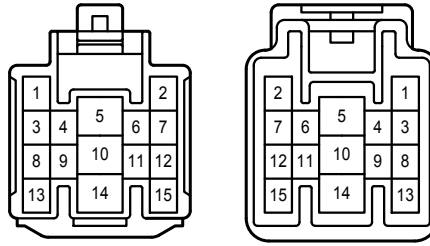

CA2
White

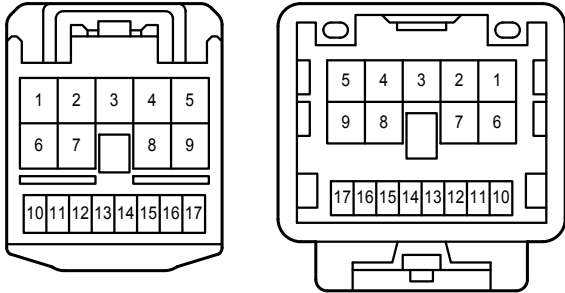

FG1
White

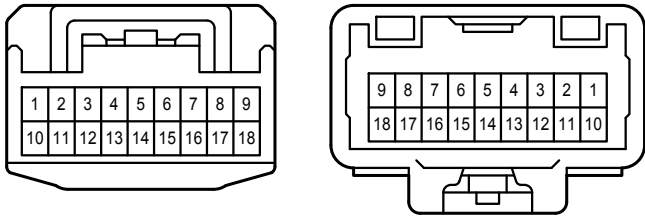

GF1
White

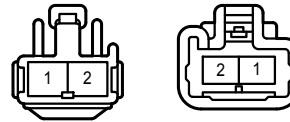

NL1
White

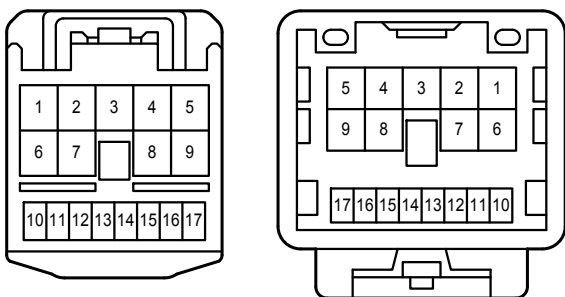

NO1
White

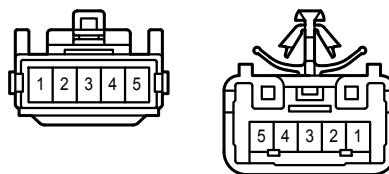

Headlight

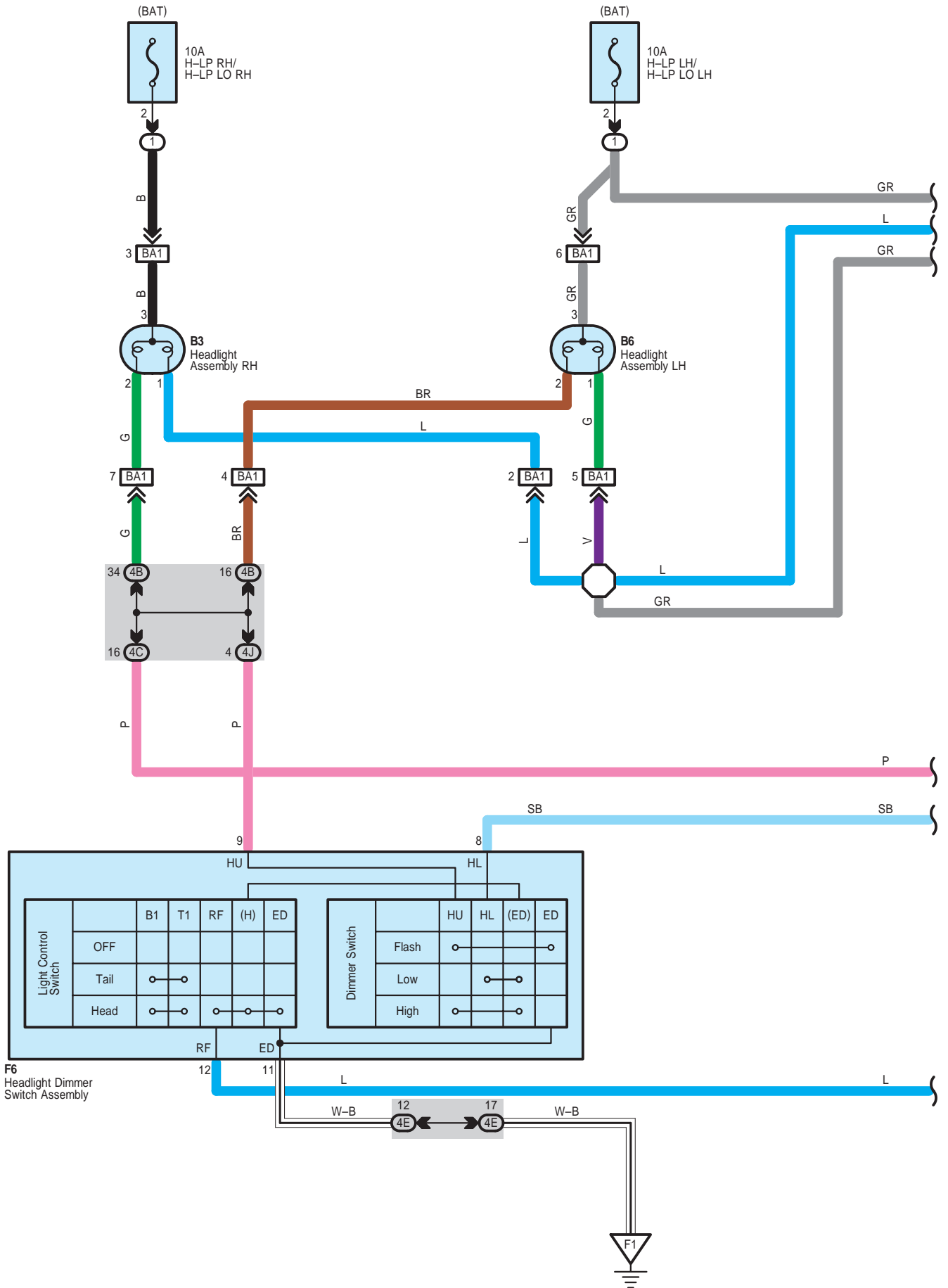

Headlight

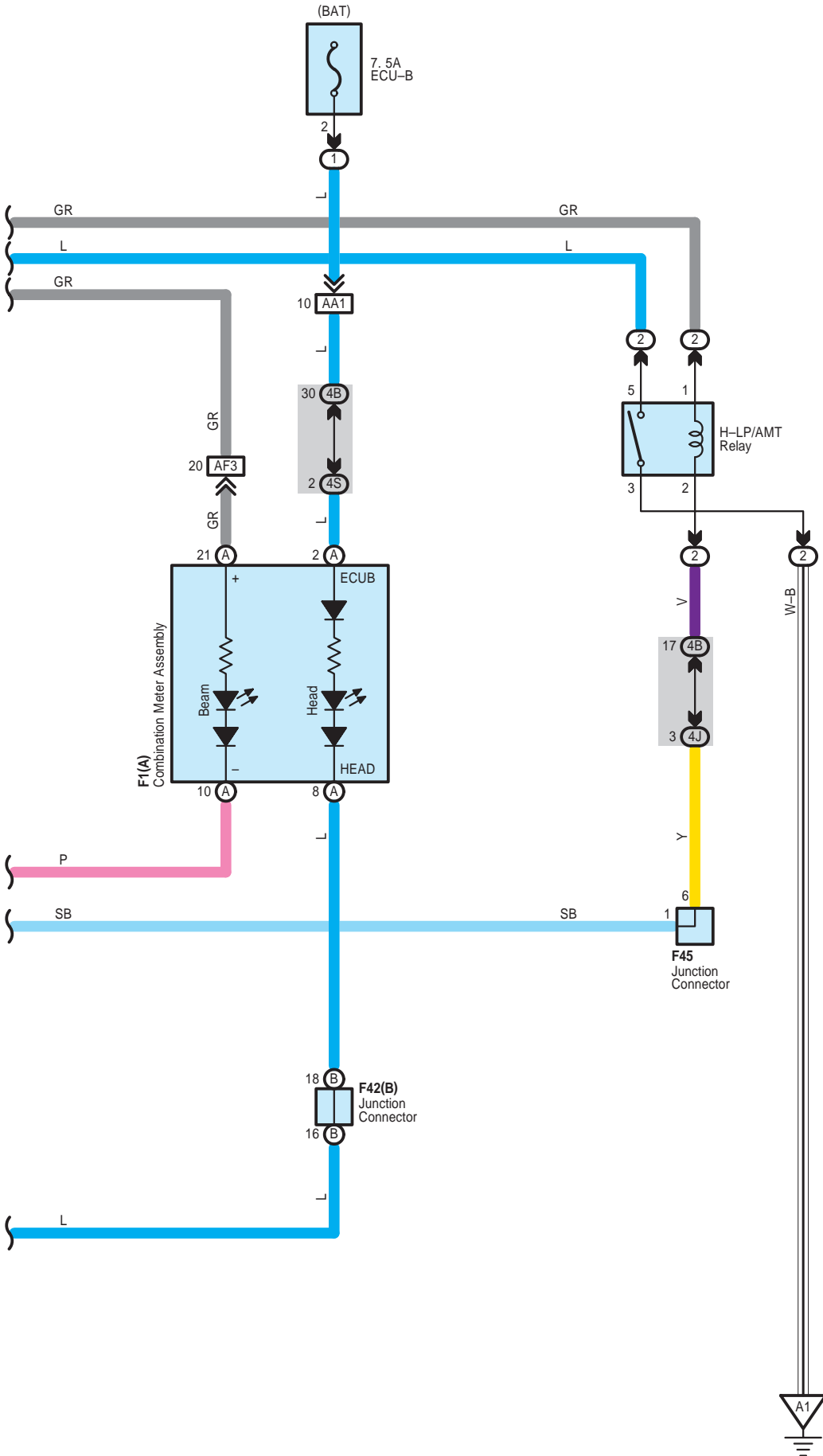

Headlight

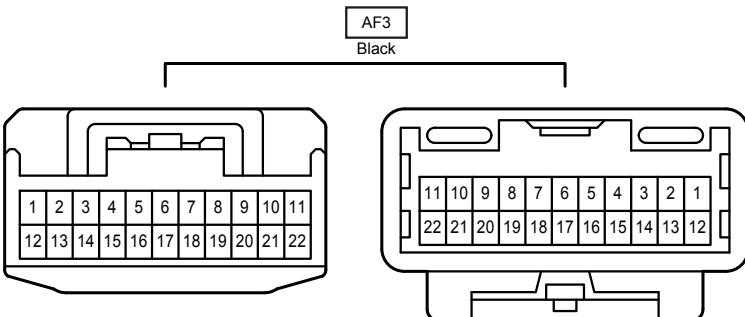
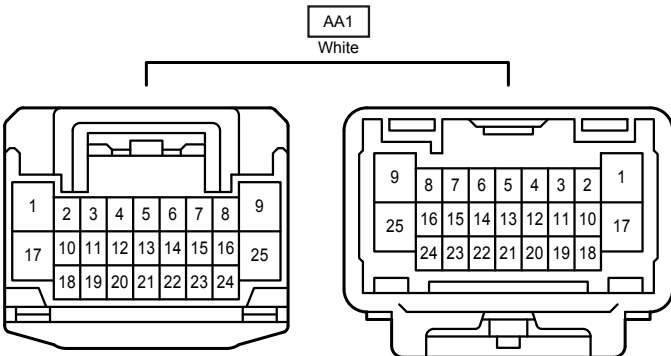
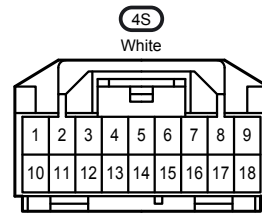
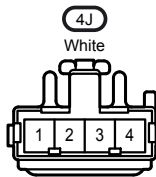
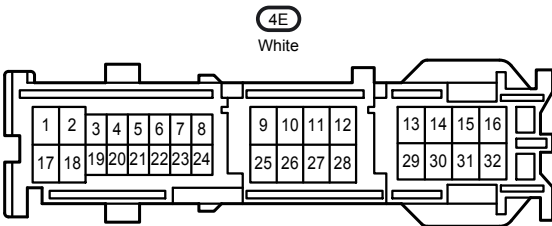
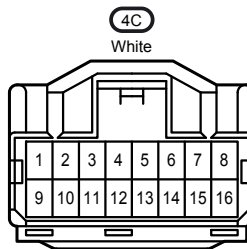
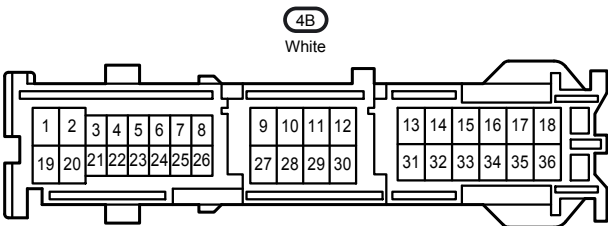
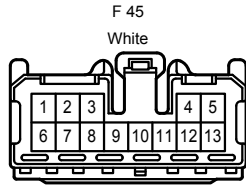
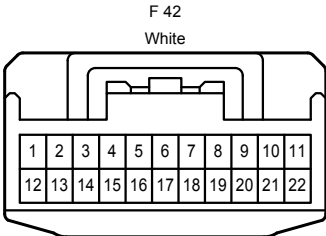
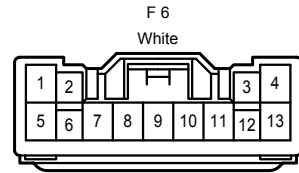
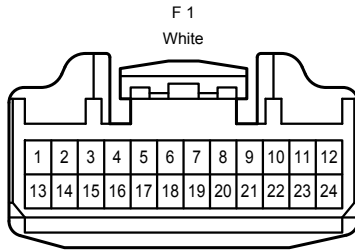
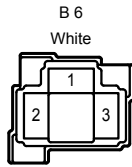
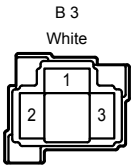

BA1
White

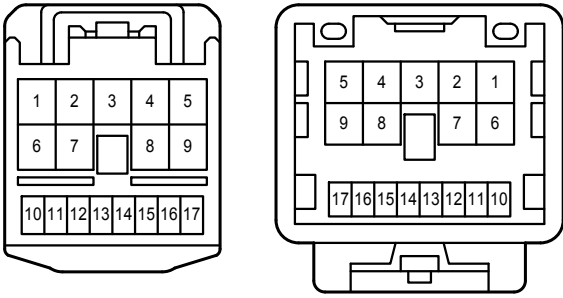

Horn

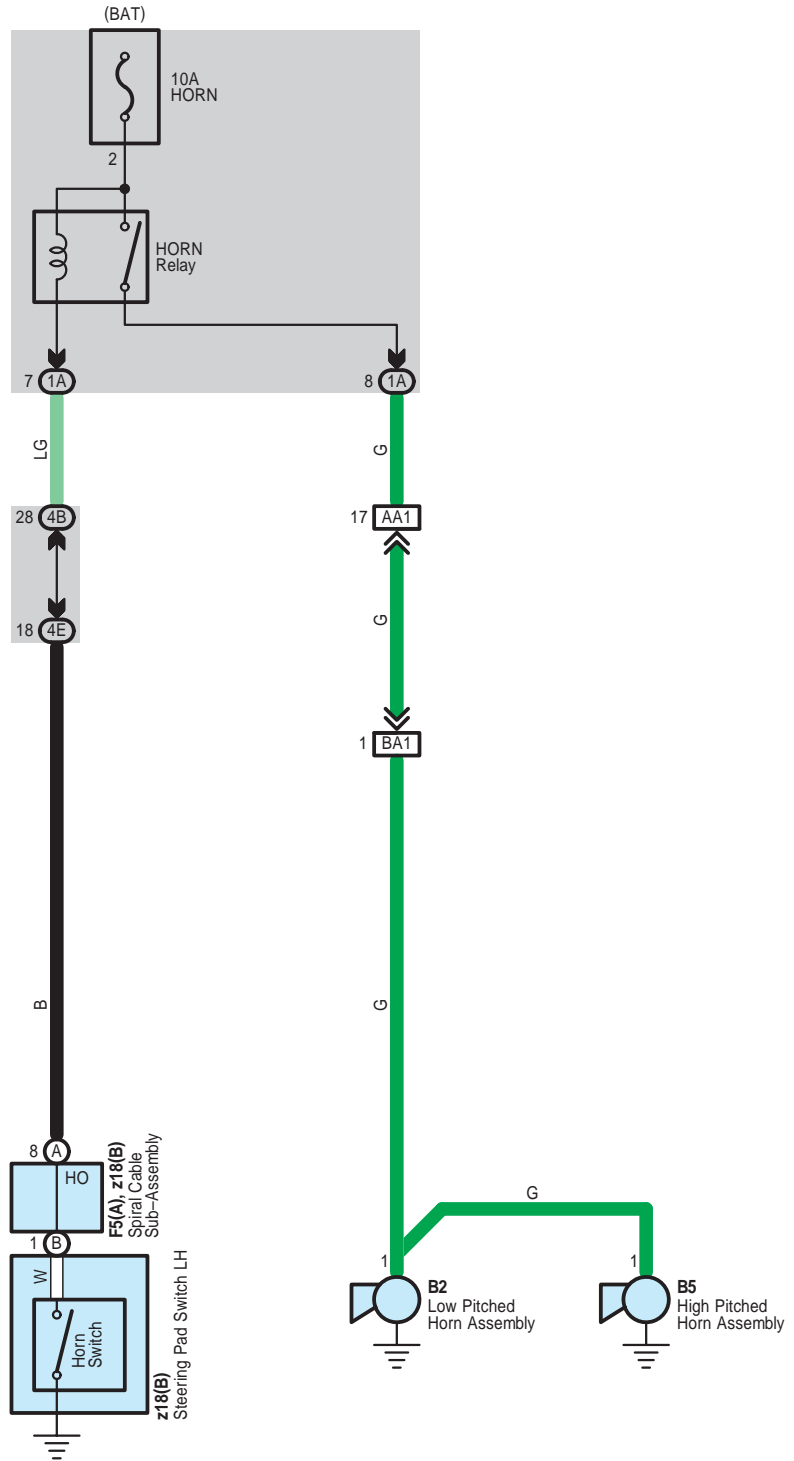

Horn

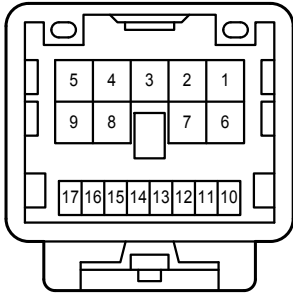
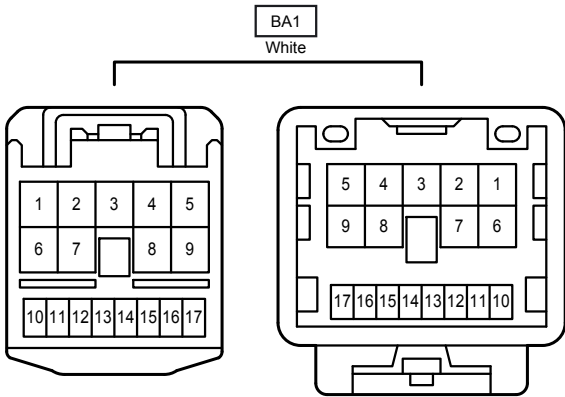
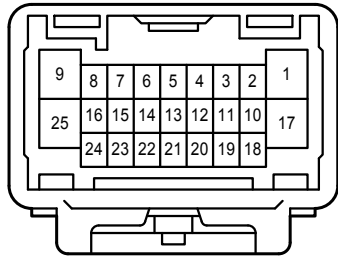
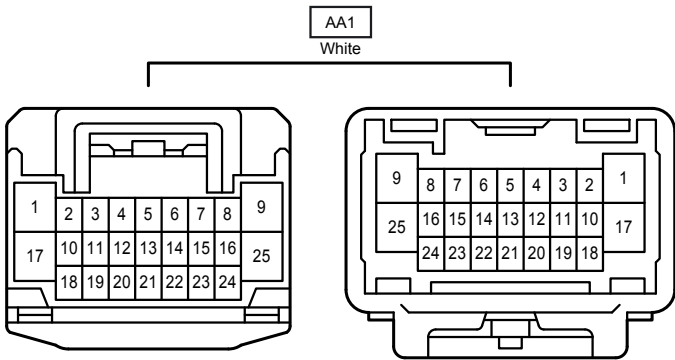
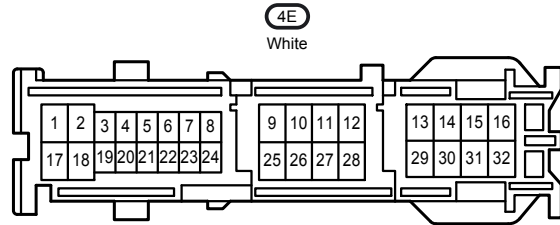
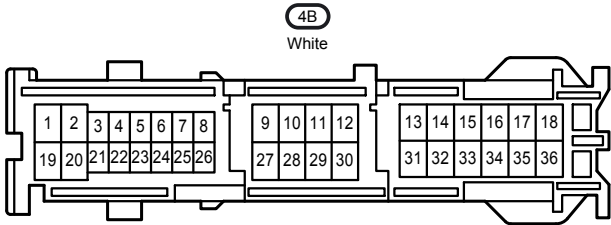
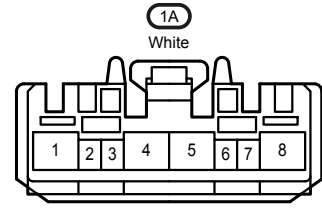
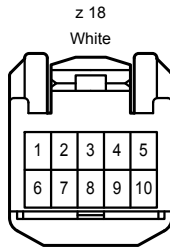
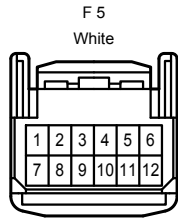
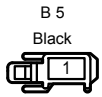
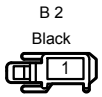

Ignition

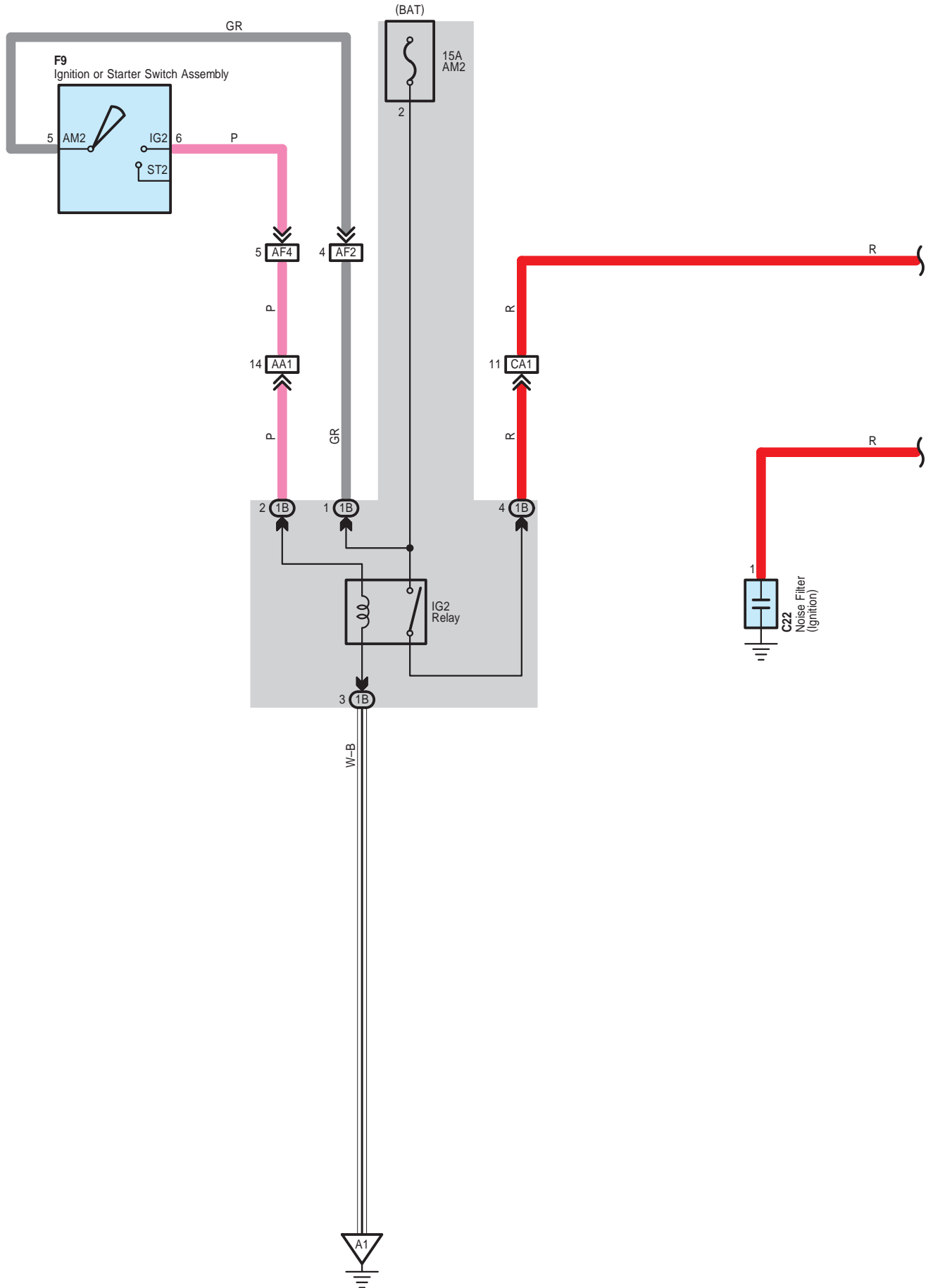

Ignition

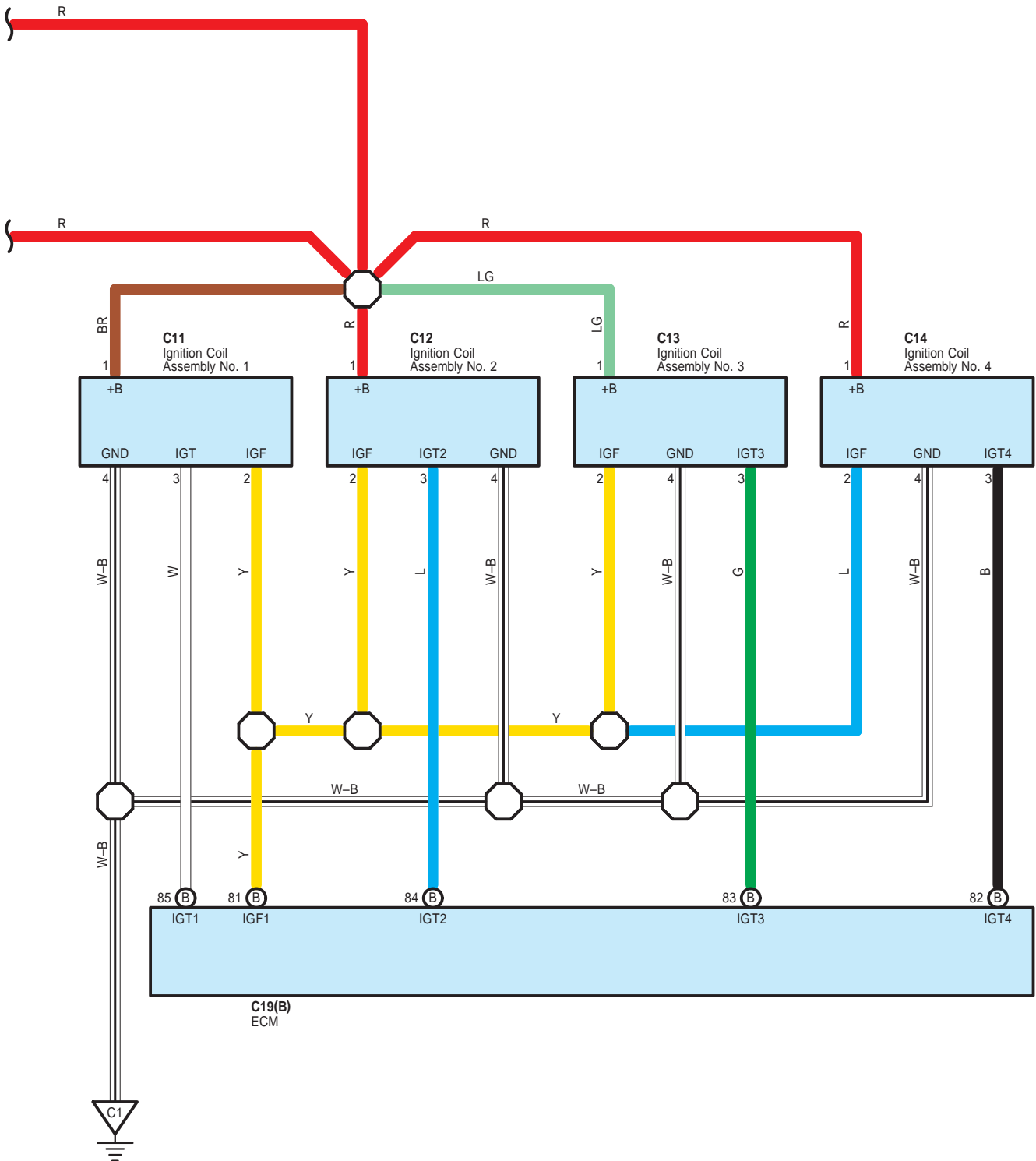

Ignition

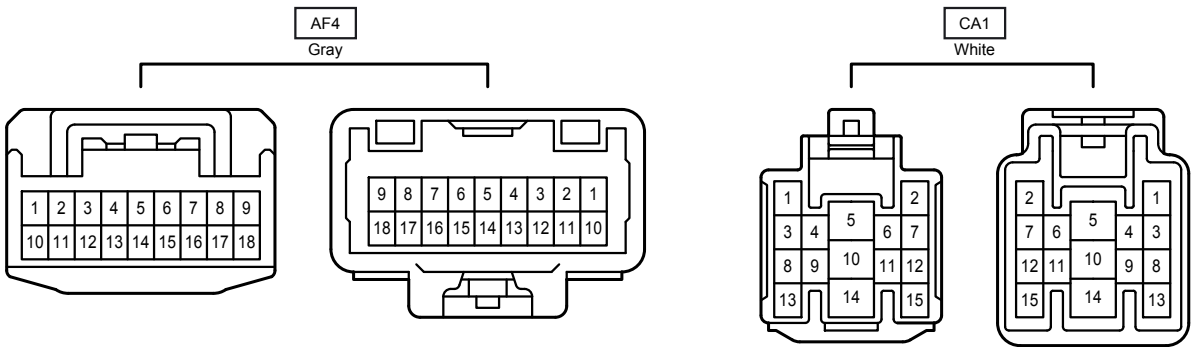
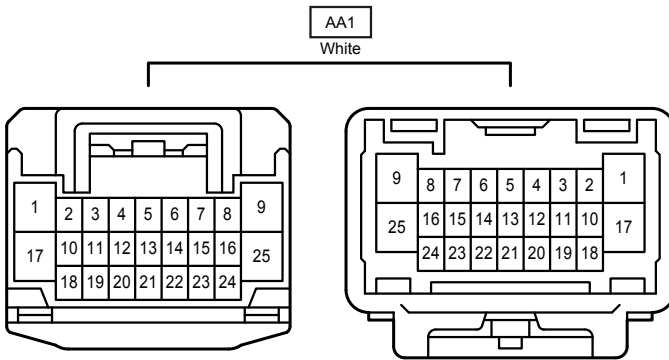
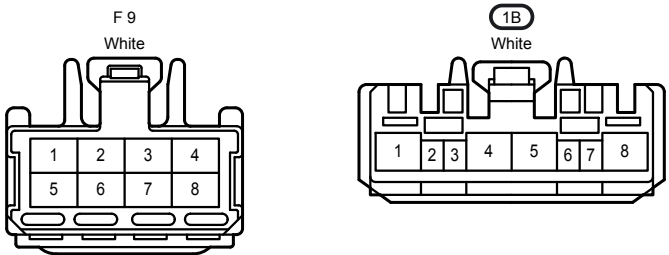
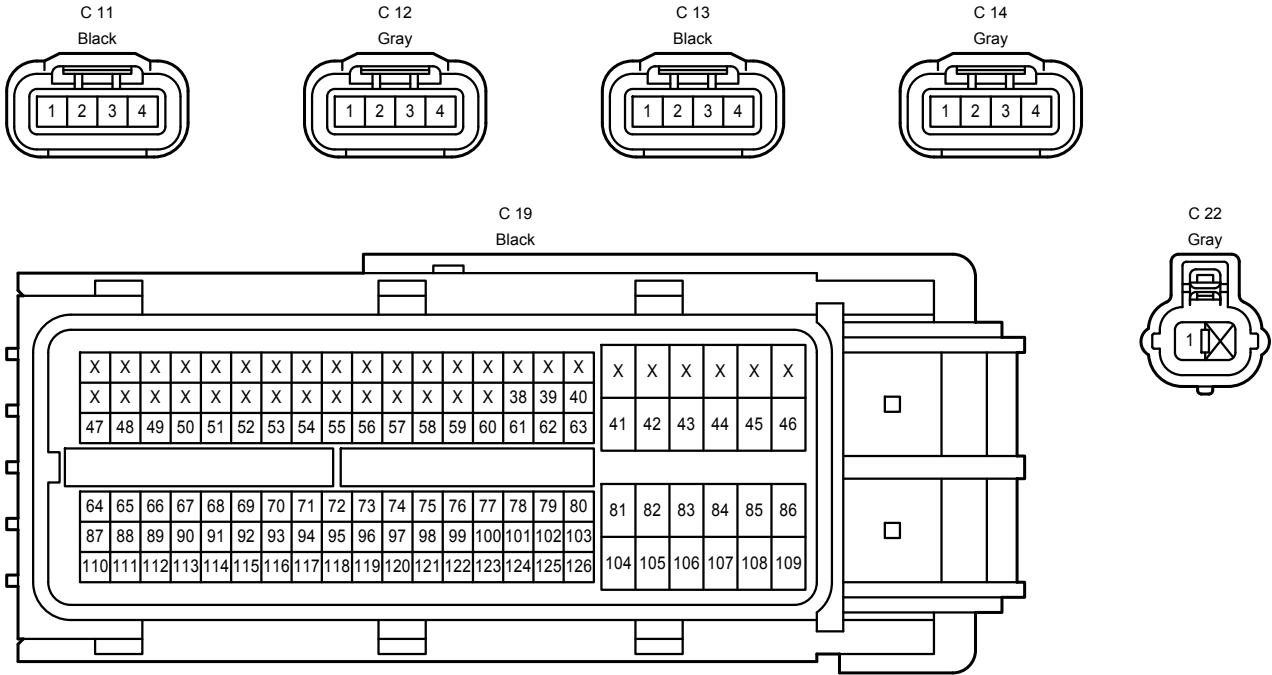

illumination , Taillight

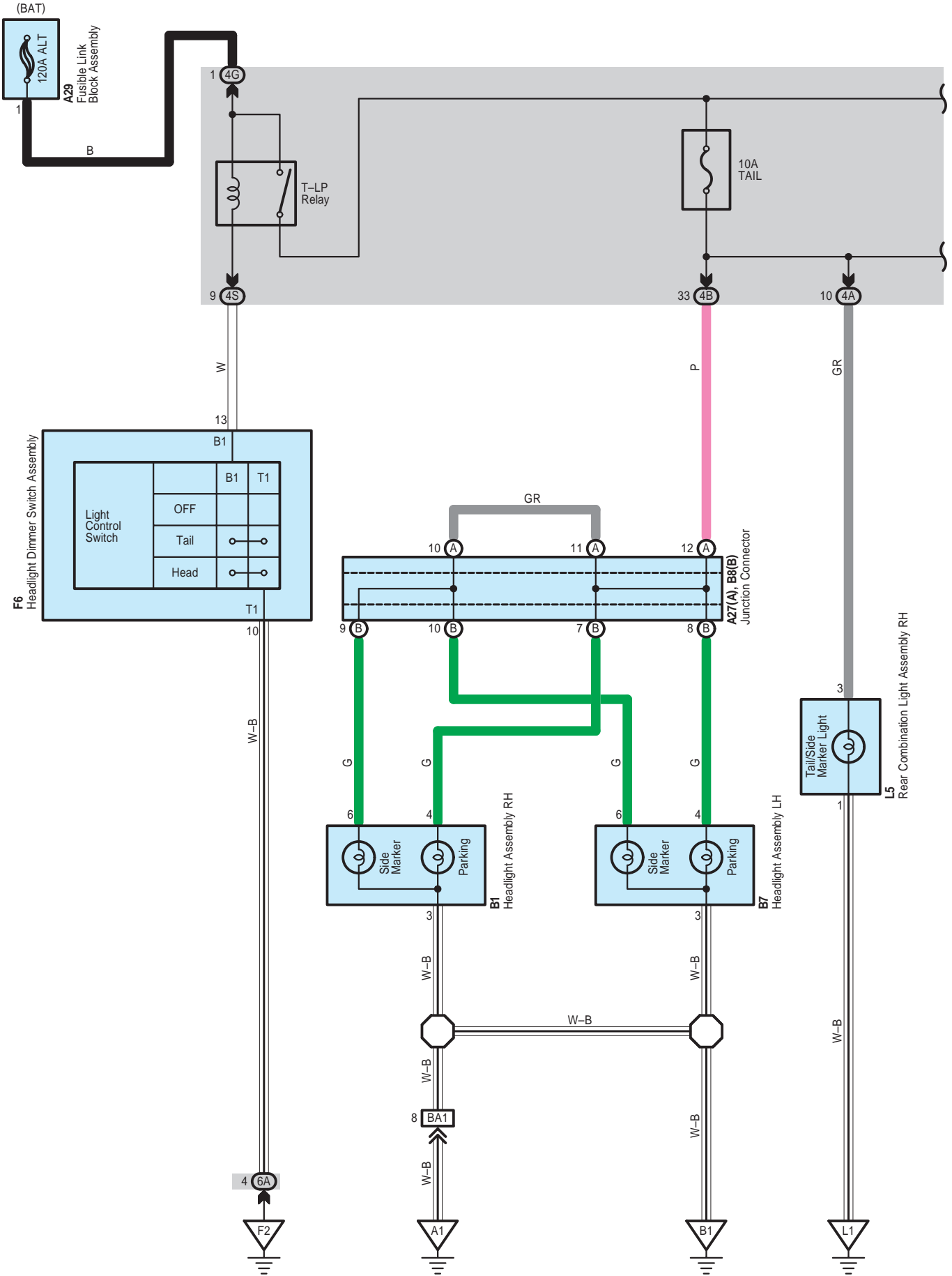

illumination , Taillight

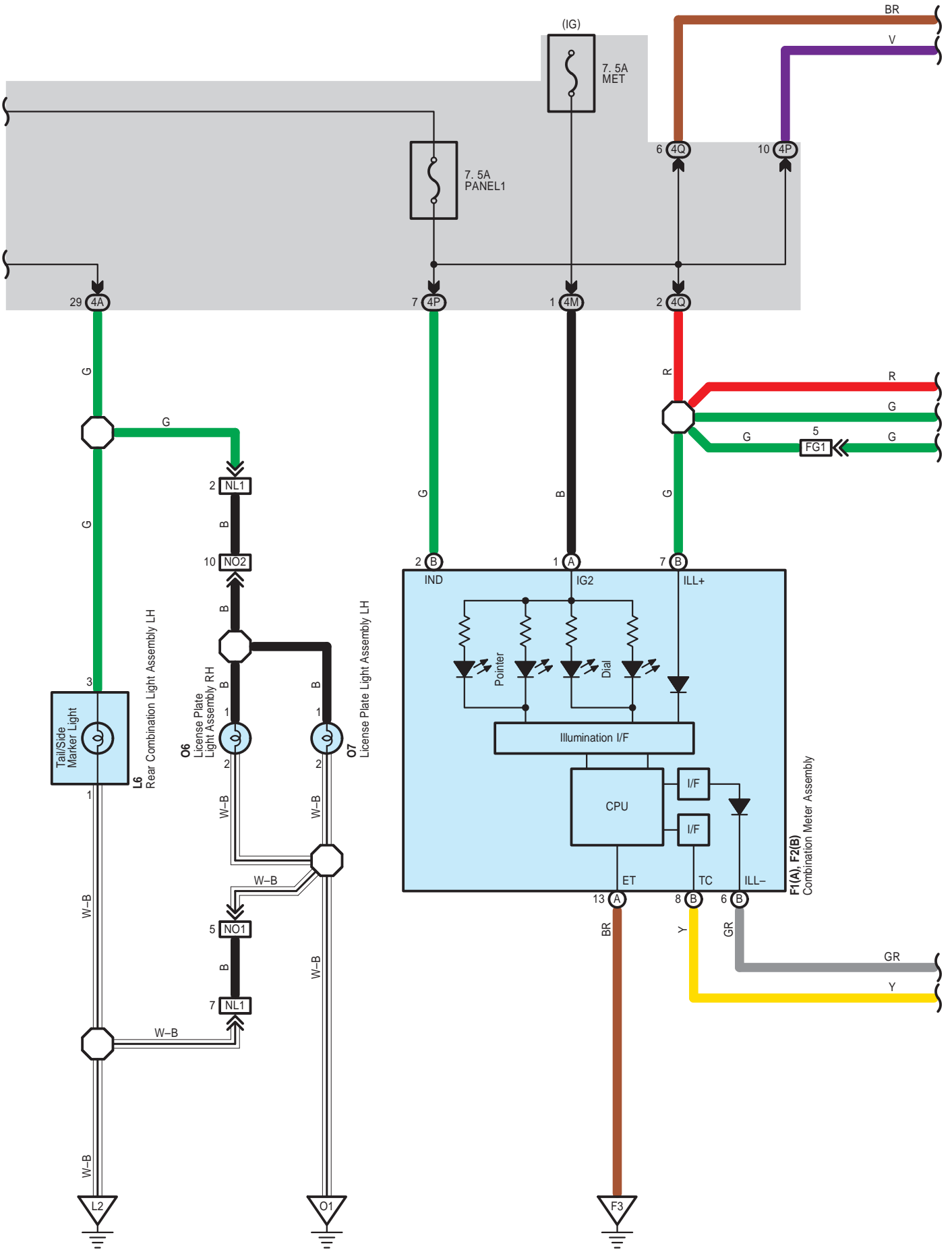

Illumination , Taillight

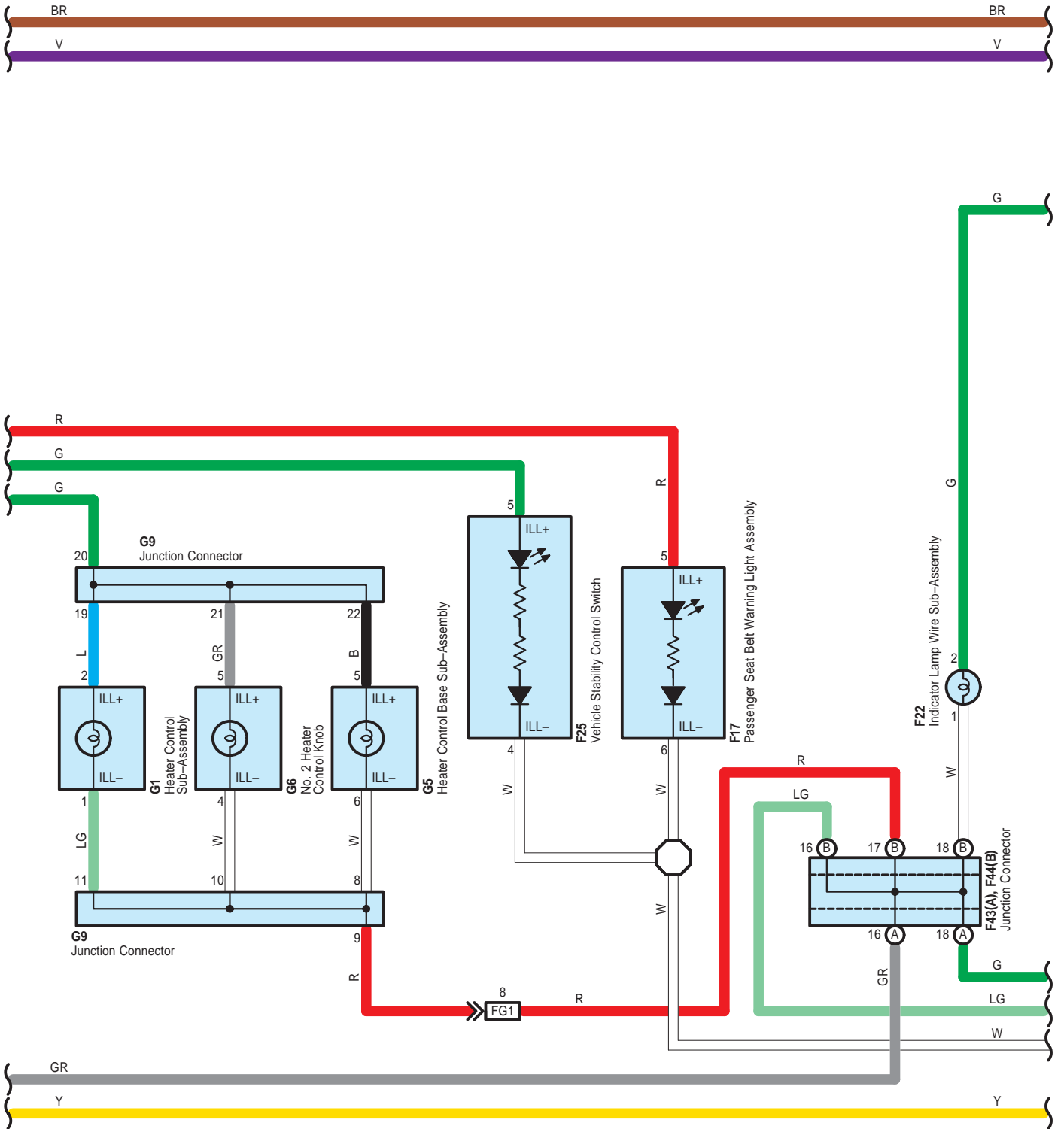

Illumination , Taillight

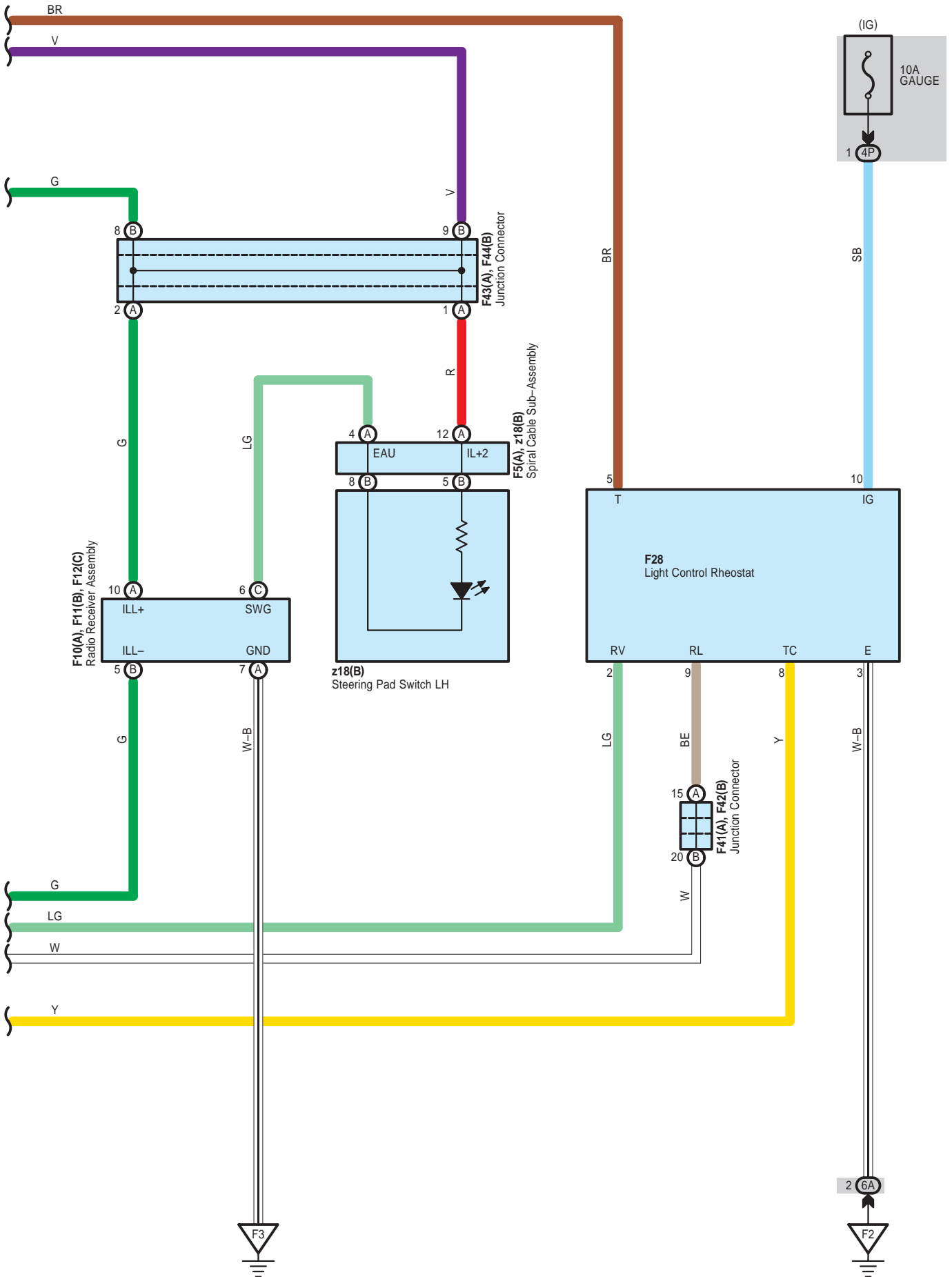

illumination , Taillight

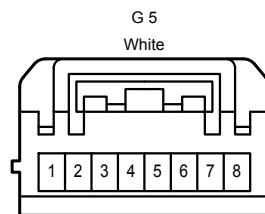
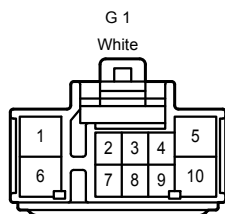
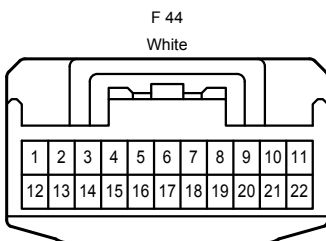
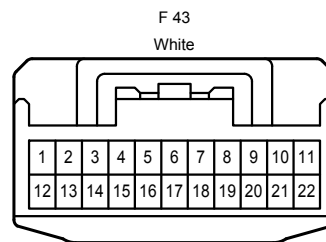
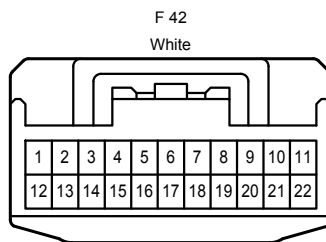
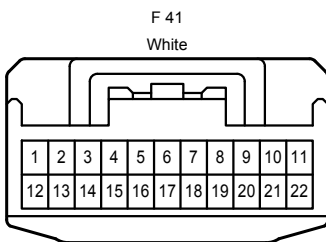
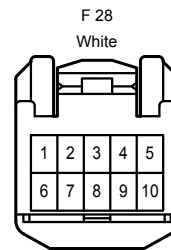
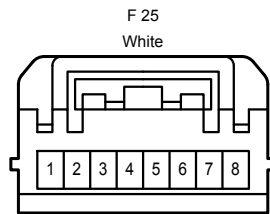
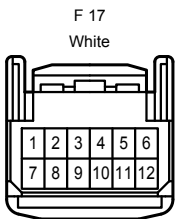
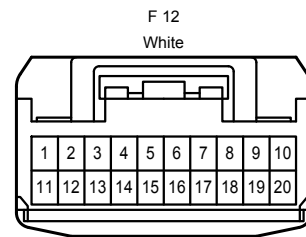
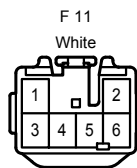
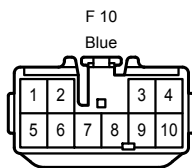
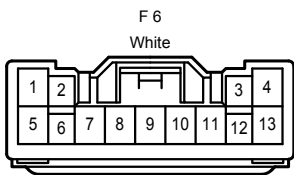
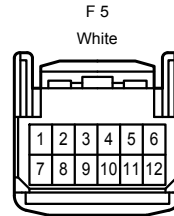
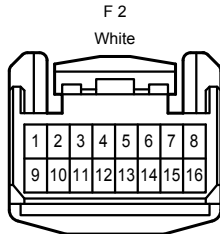
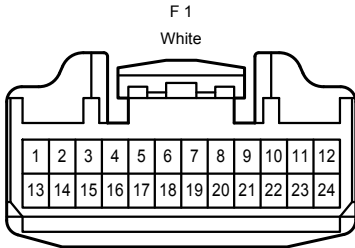
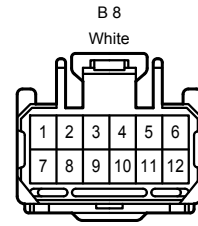
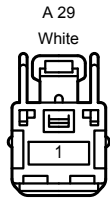
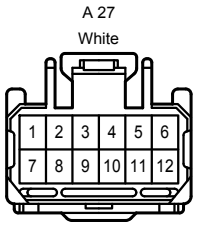

Illumination , Taillight

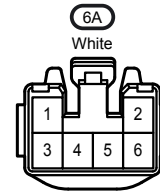
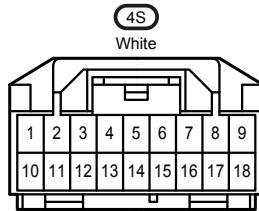
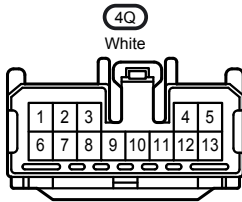
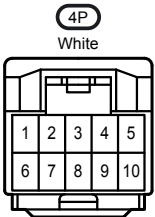
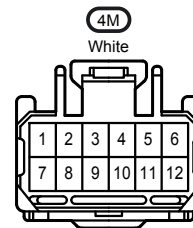
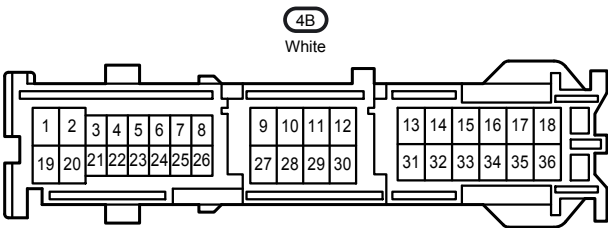
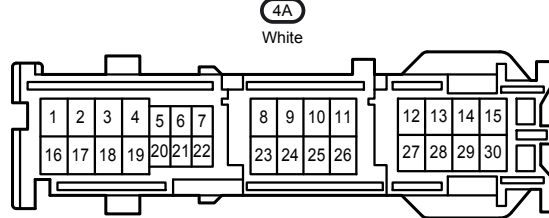
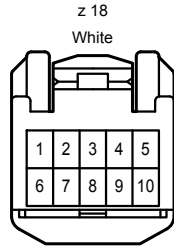
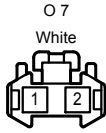
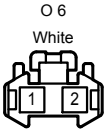
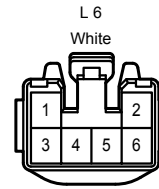
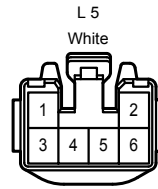
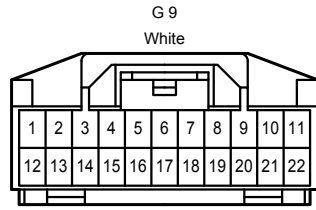
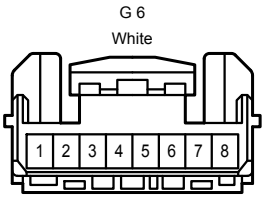

BA1
White

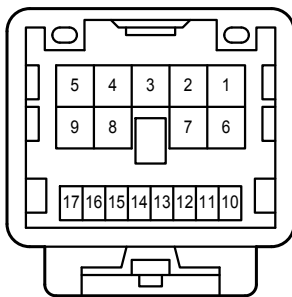
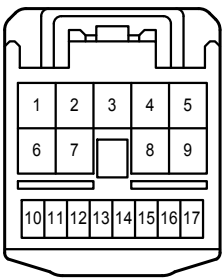

FG1
White

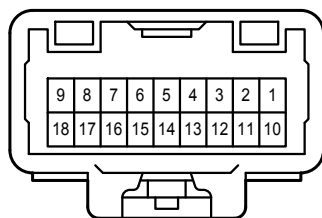
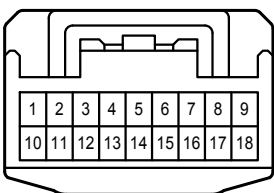

Illumination , Taillight

NL1
White

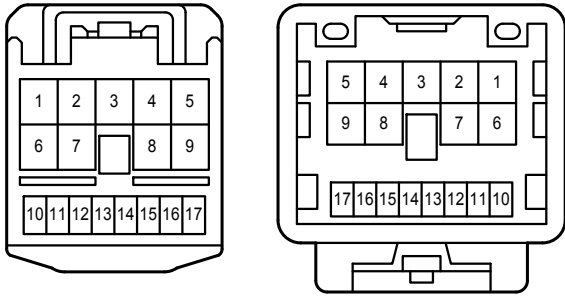

NO1
White

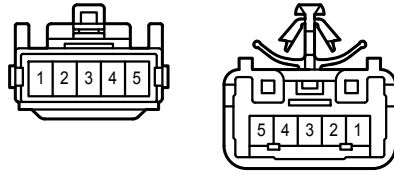

NO2
White

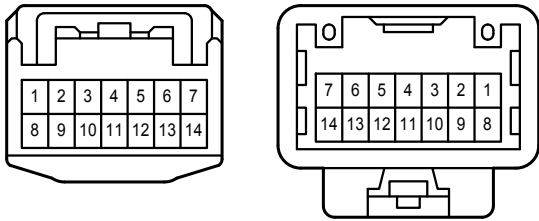

Interior Light

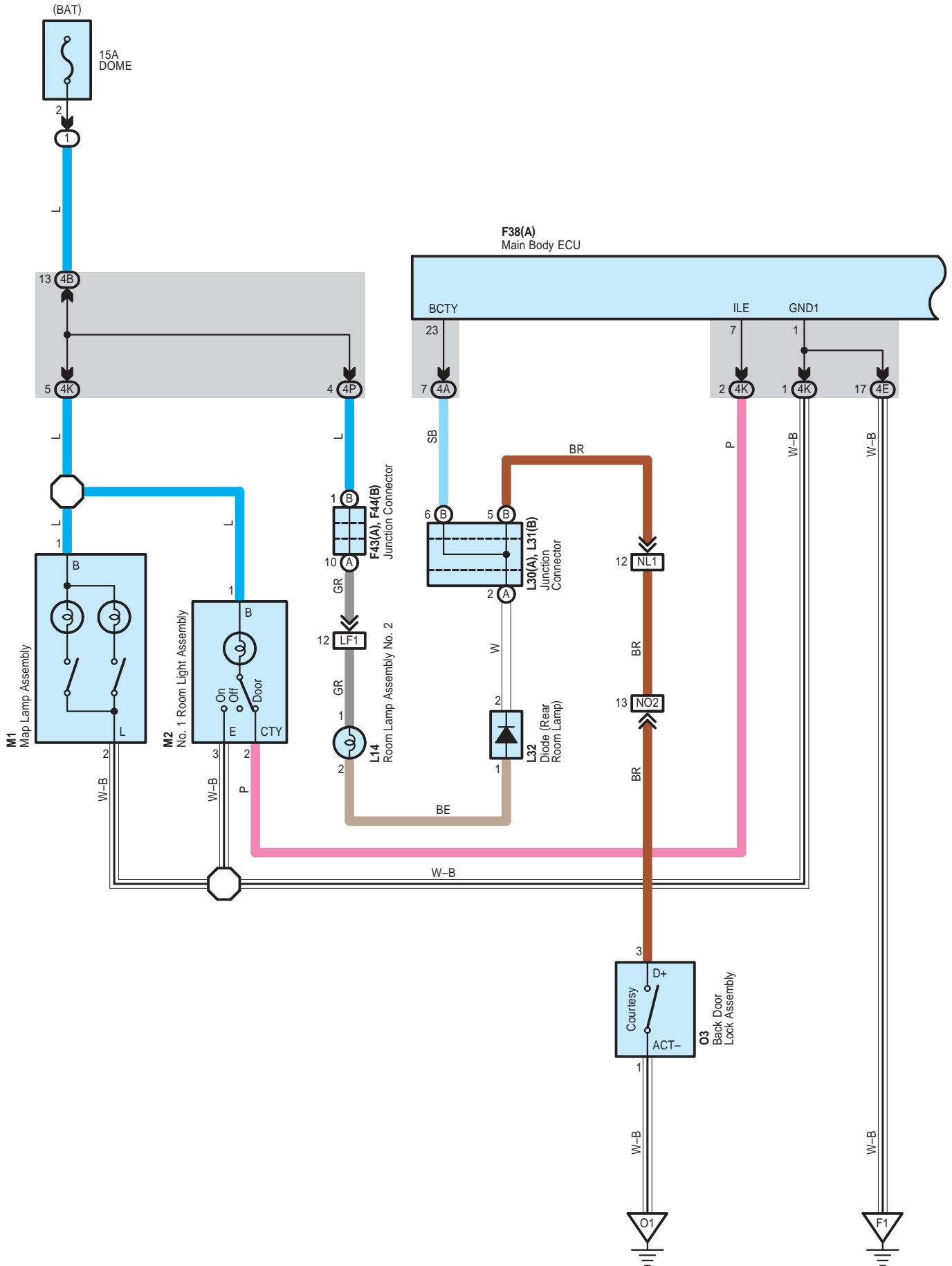

Interior Light

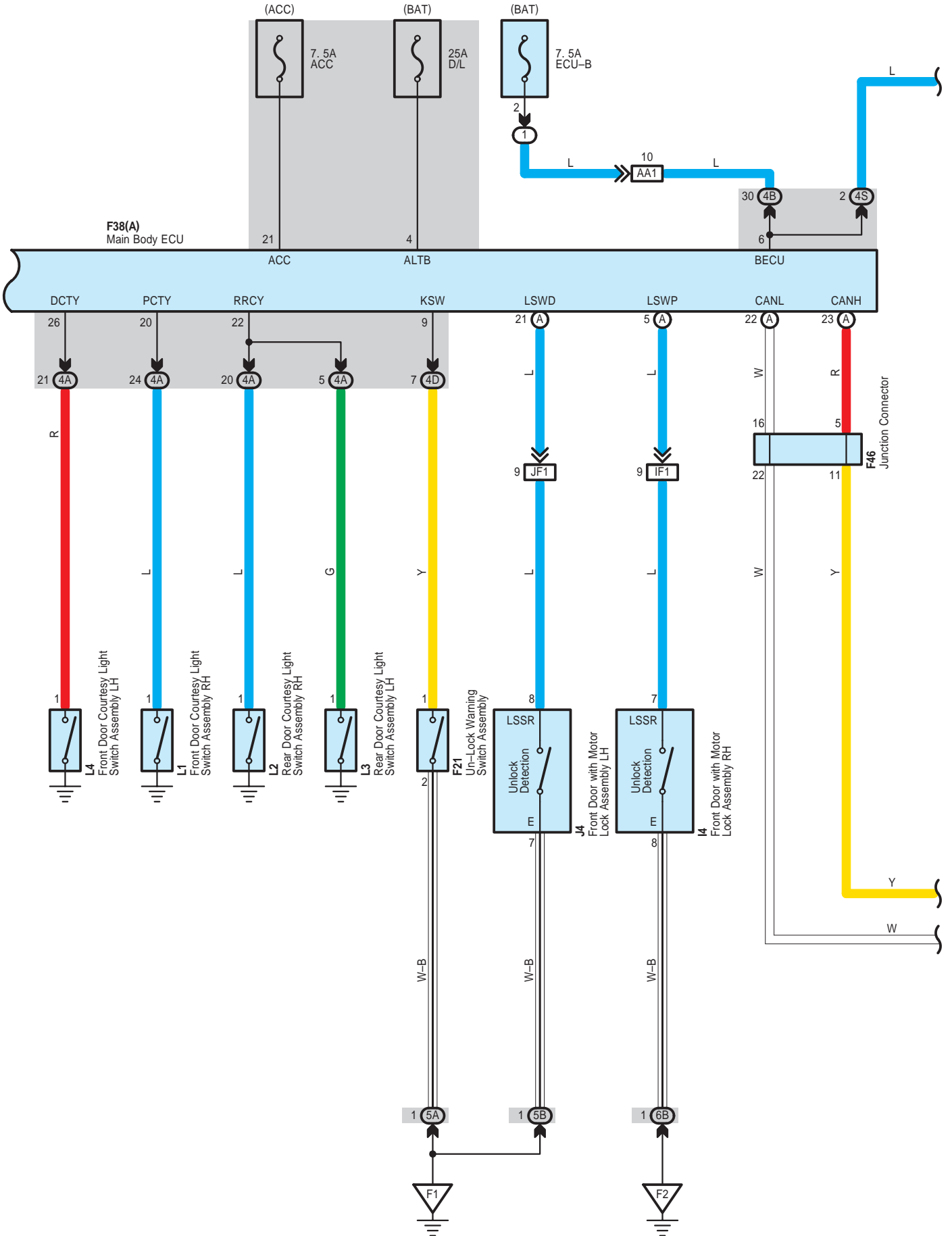

Interior Light

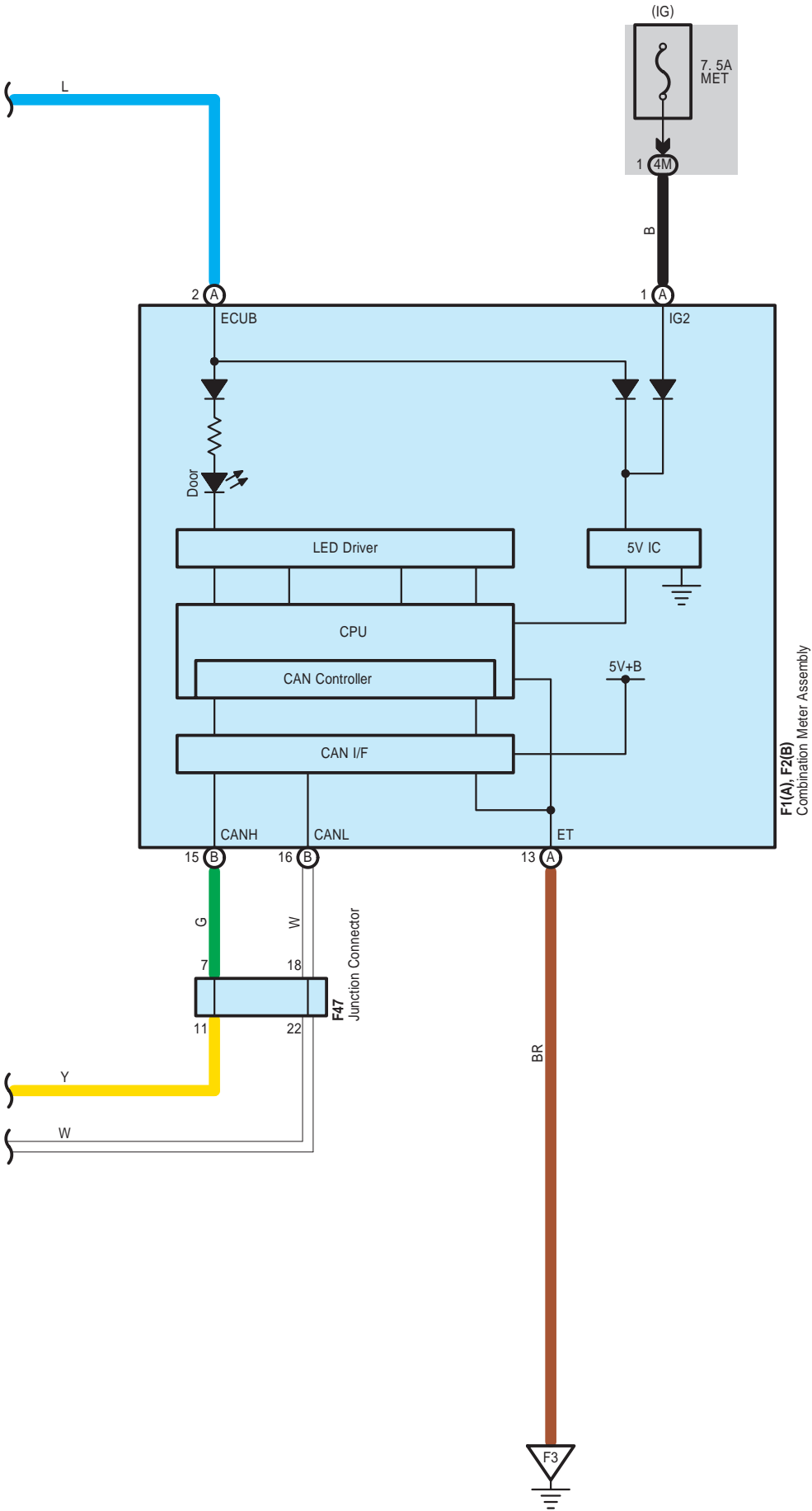

Interior Light

F 1

White

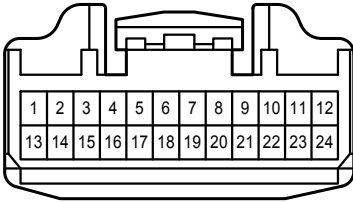

F 2

White

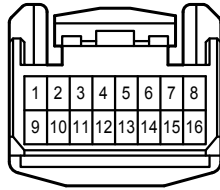

F 21

White



F 38

White

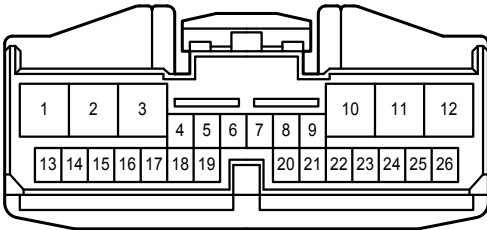

F 43

White

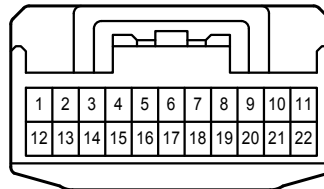

F 44

White

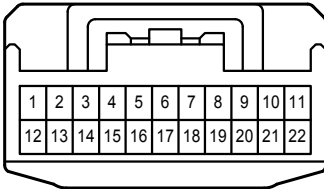

F 46

White

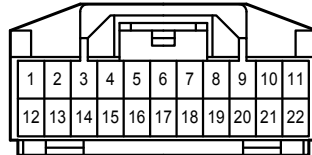

F 47

White

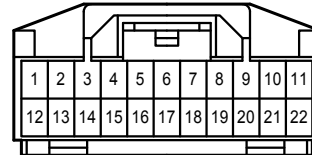

I 4

White

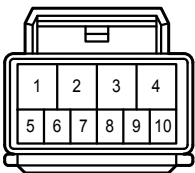

J 4

White

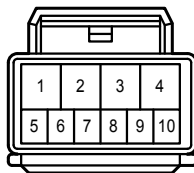

L 1

White



L 2

White



L 3

White



L 4

White



L 14

White



L 30

White

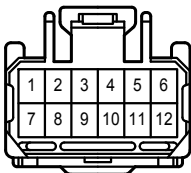

L 31

White

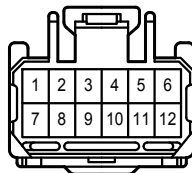

L 32

Black



M 1

White



M 2

Gray

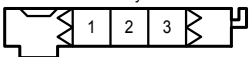

O 3

Black

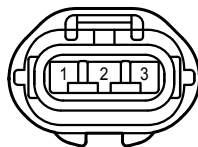

4A

White

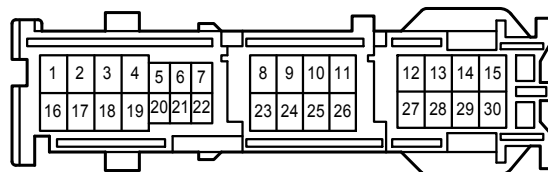

Interior Light

4B
White

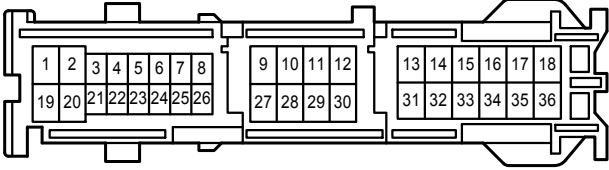

4D
White

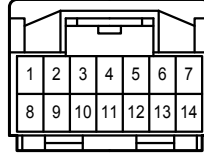

4E
White

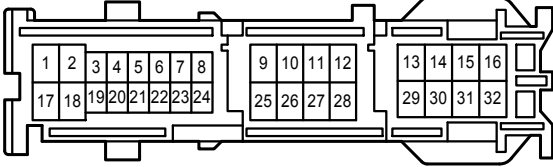

4K
White

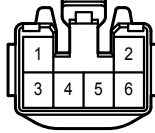

4M
White

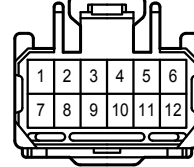

4P
White

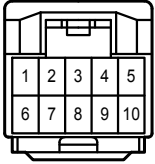

4S
White

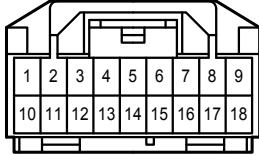

5A
White

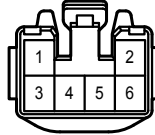

5B
White

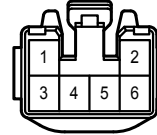

6B
White

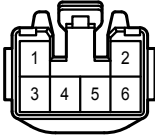

AA1
White

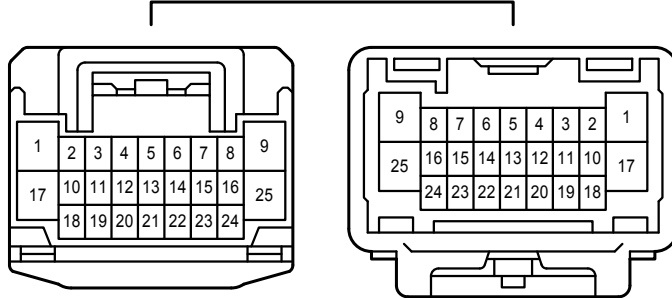

IF1
White

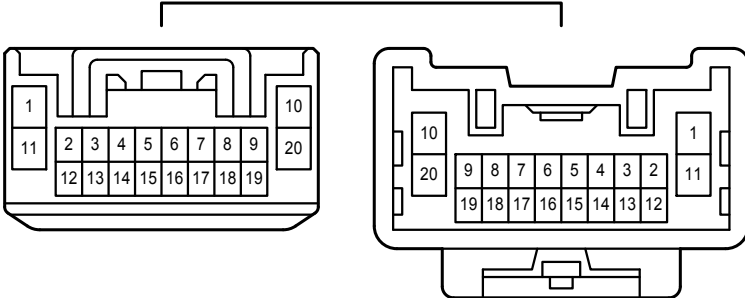

Interior Light

JF1
White

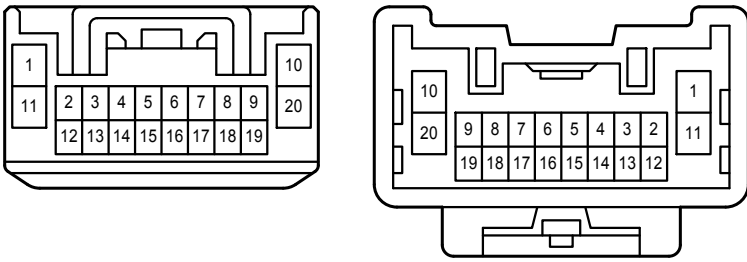

LF1
White

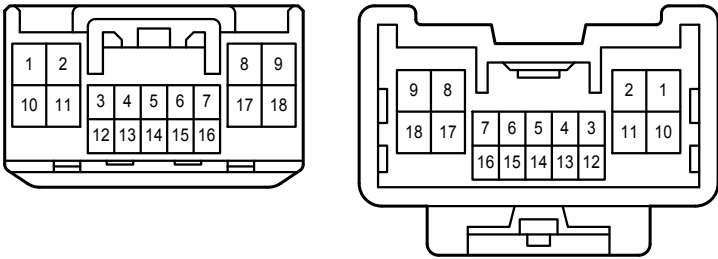

NL1
White

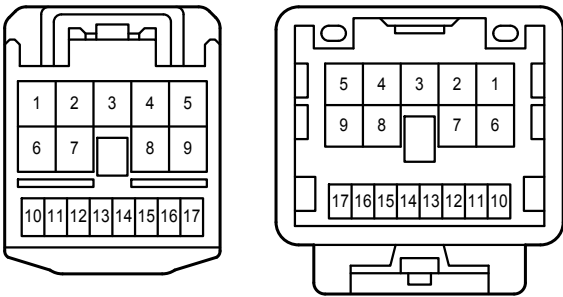

NO2
White

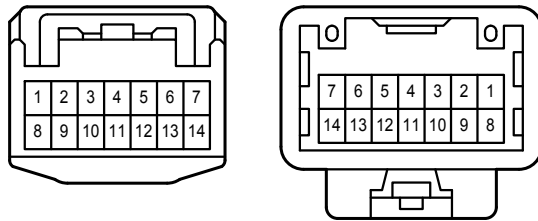

Key Reminder , Light Reminder

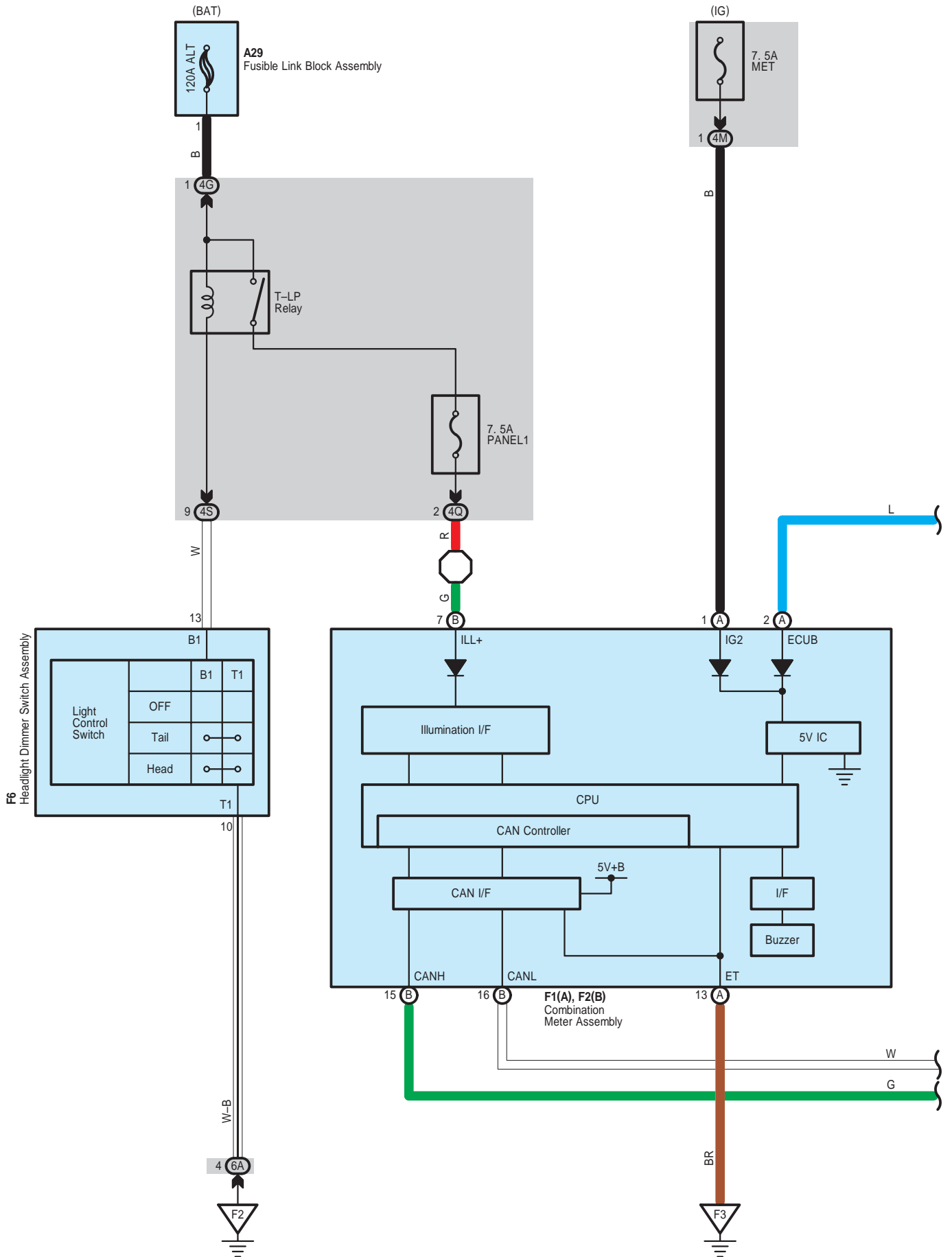

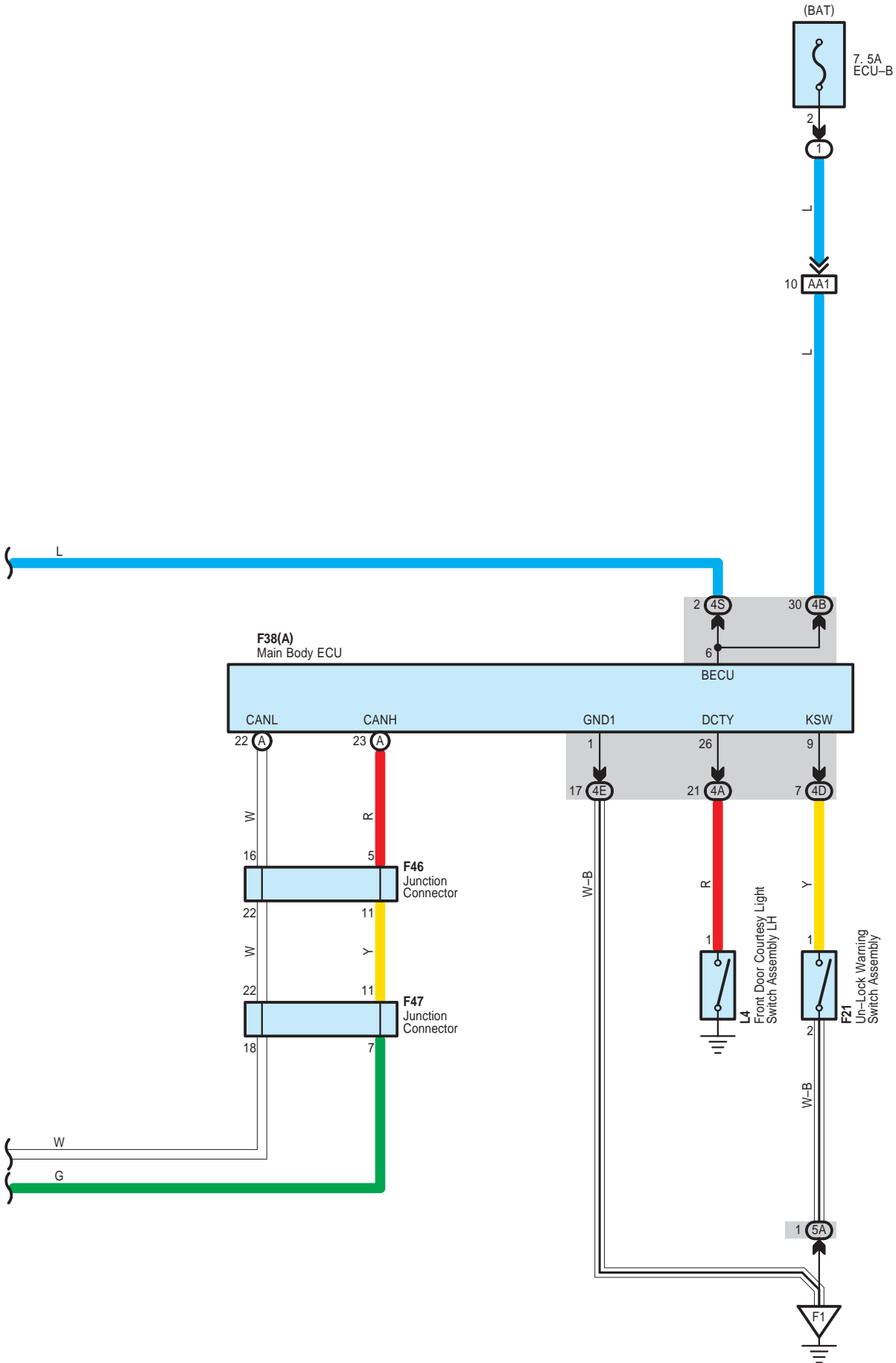

Key Reminder , Light Reminder

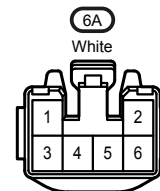
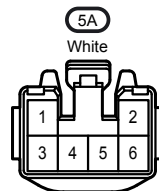
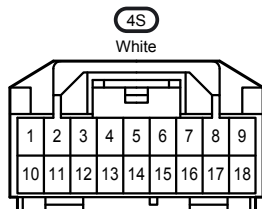
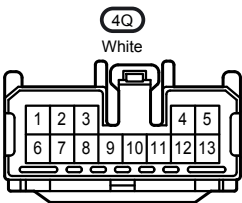
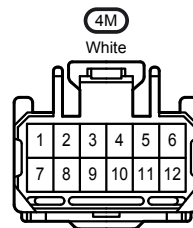
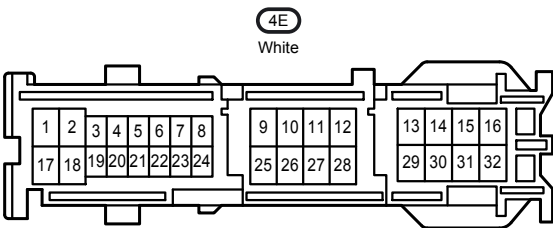
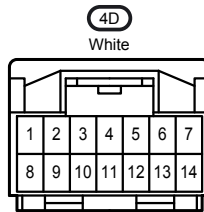
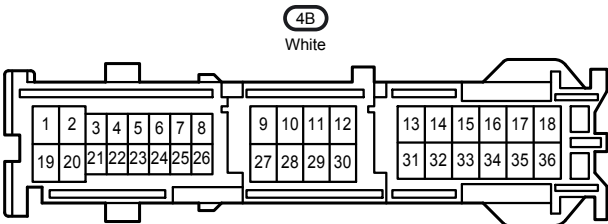
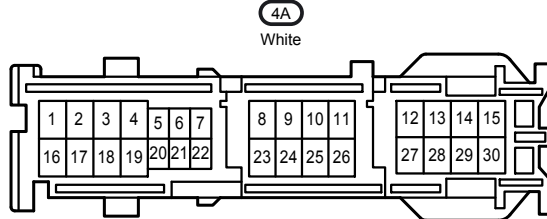
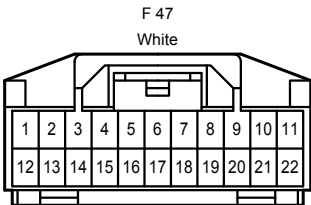
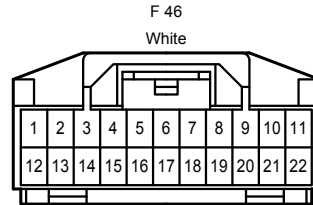
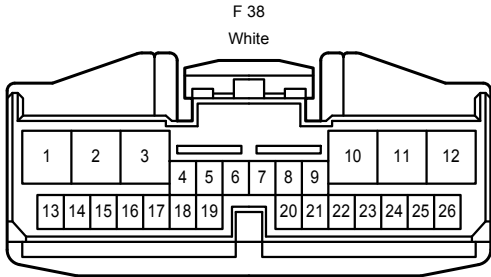
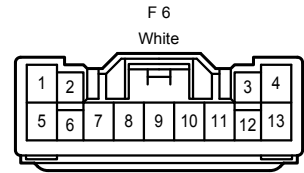
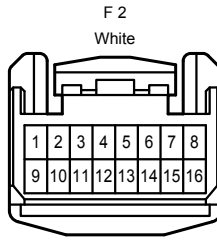
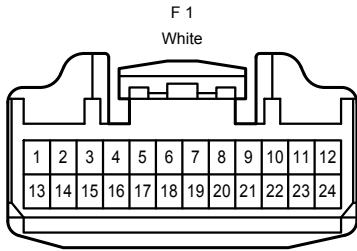
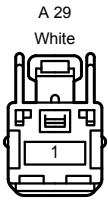

AA1
White

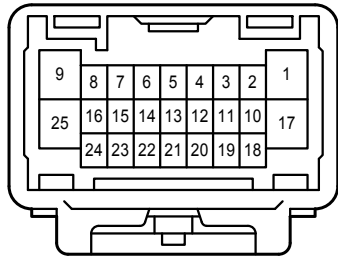
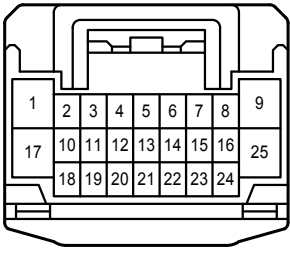

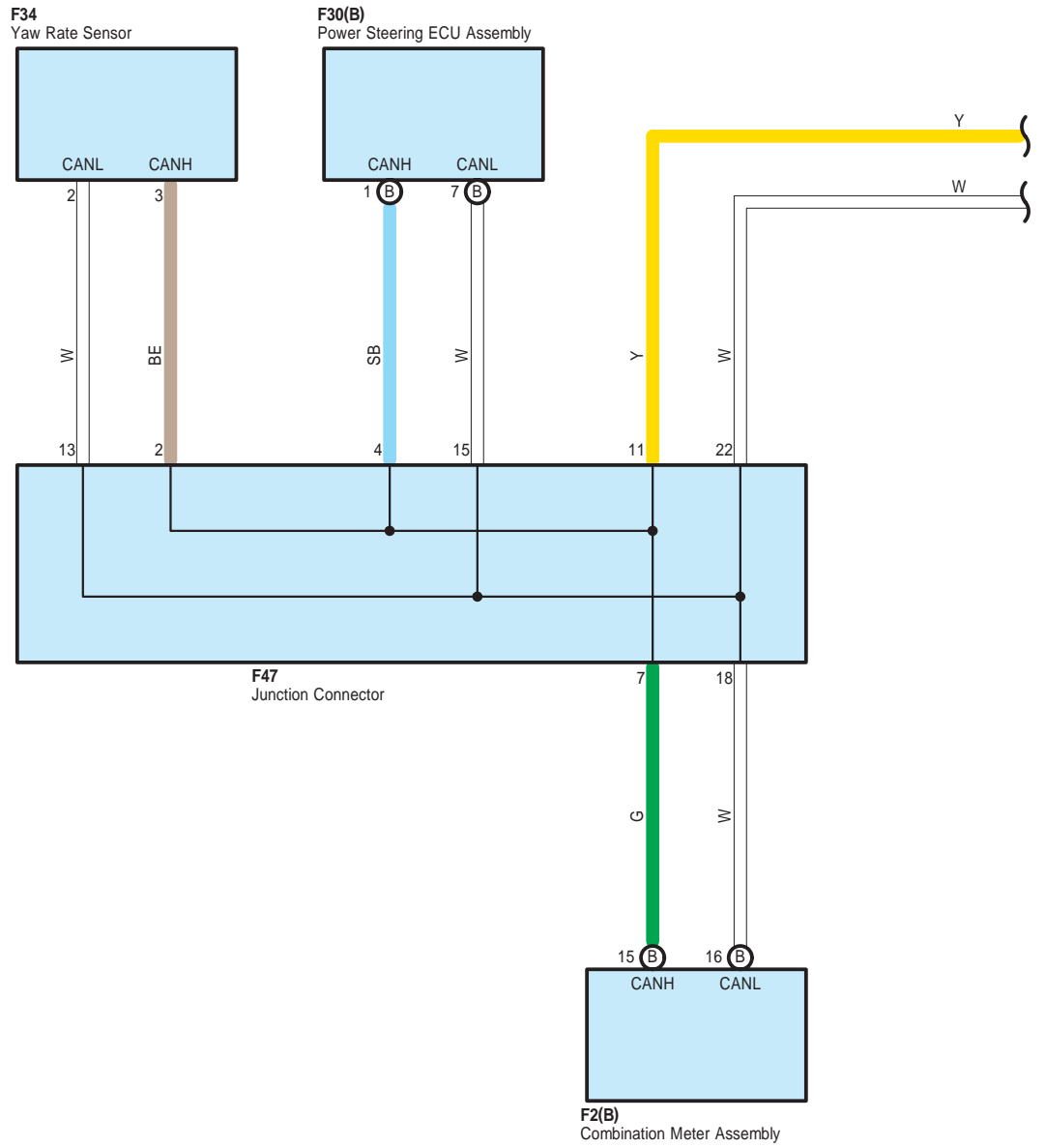

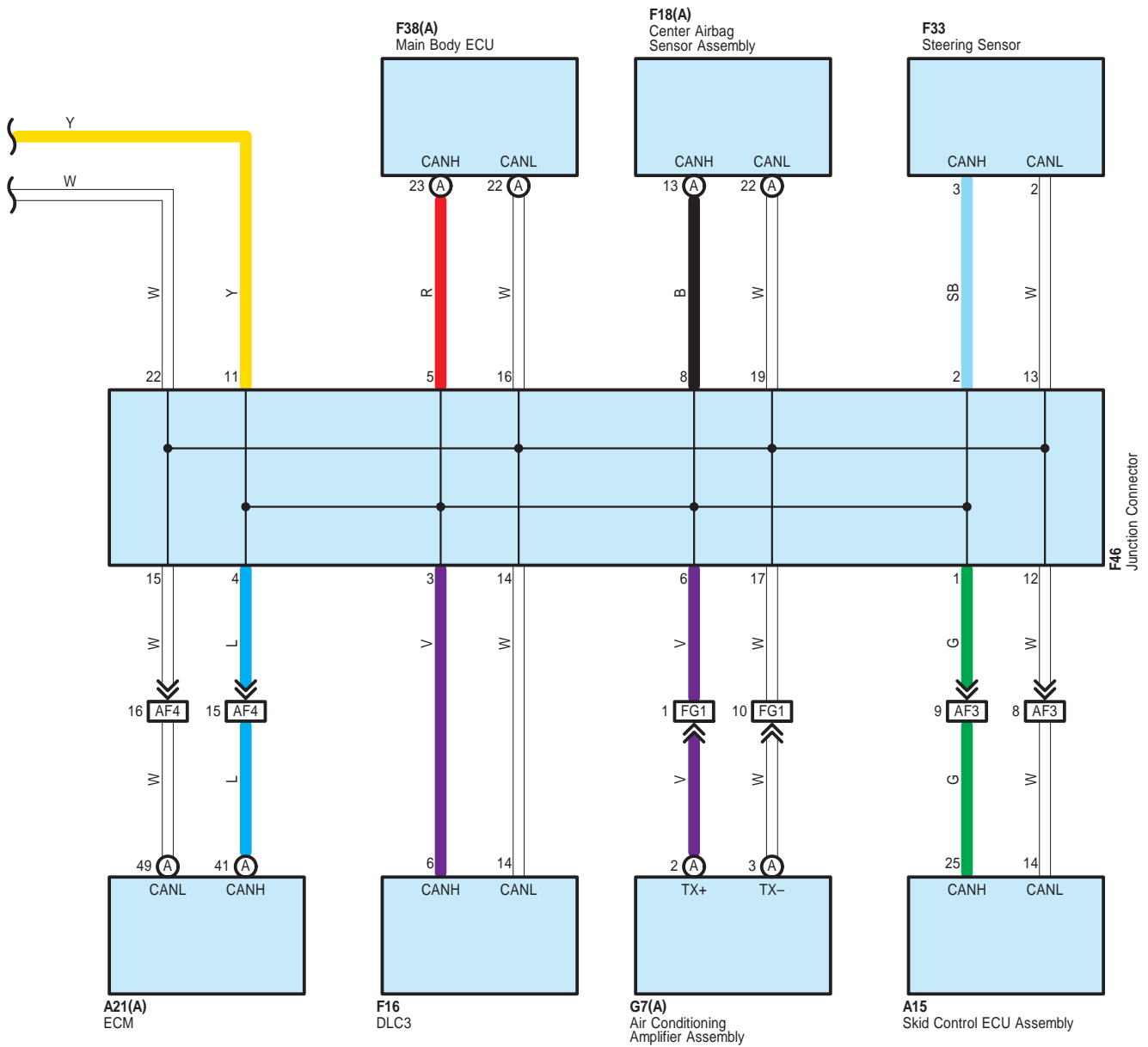

A 15
Black

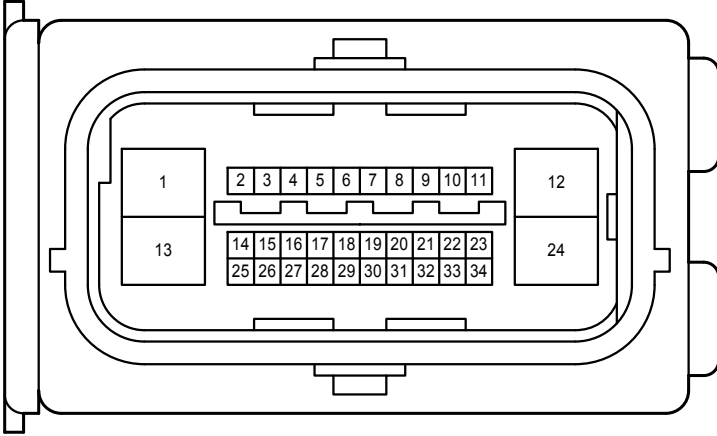

A 21
Black

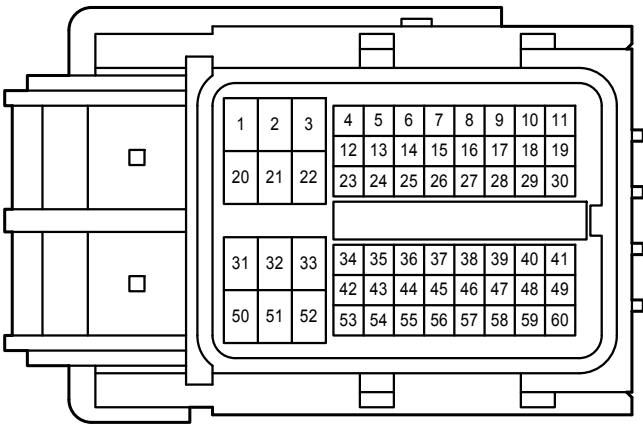

F 2
White

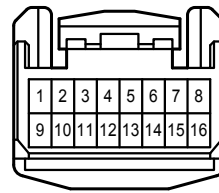

F 16
White

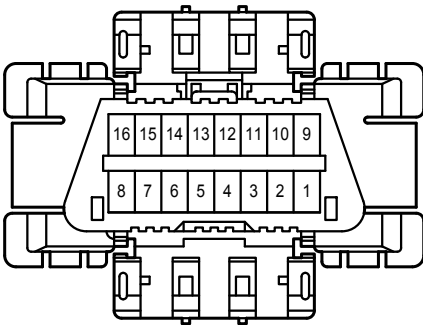

F 18
Yellow

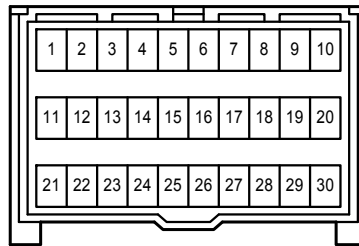

F 30
White

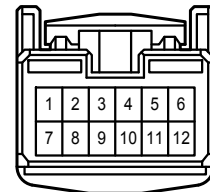

F 33
Black

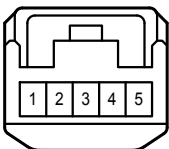

F 34
Black

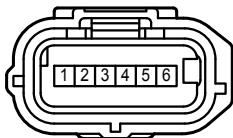

F 38
White

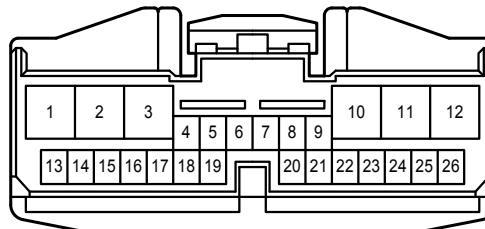

F 46
White

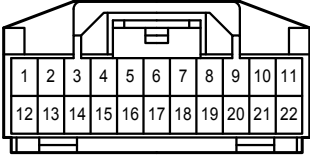

F 47
White

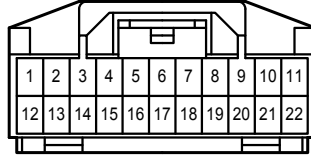

G 7
White

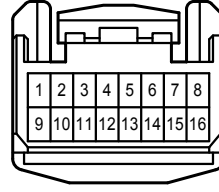

AF3
Black

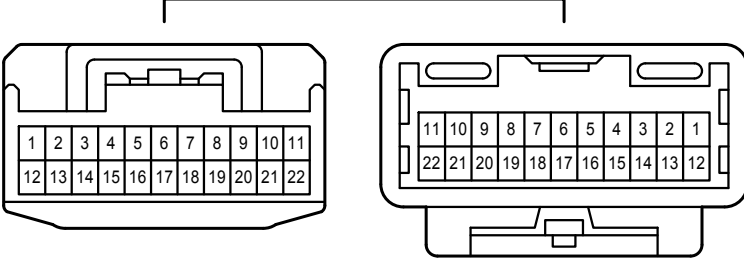

AF4
Gray

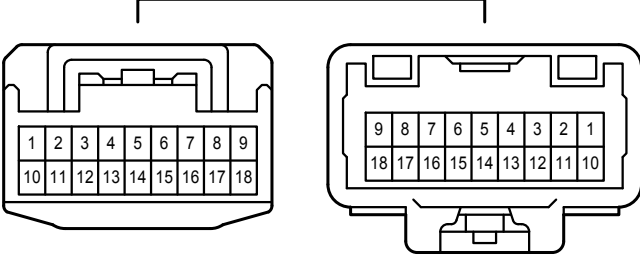

FG1
White

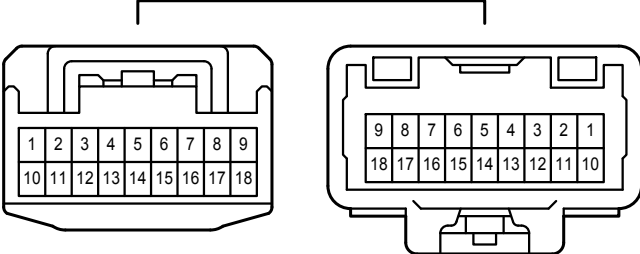

Power Outlet

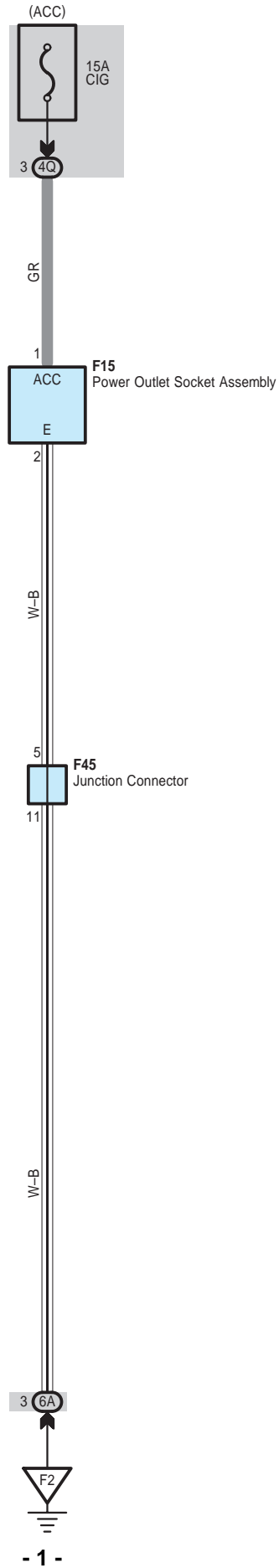

Power Outlet

F 15
White

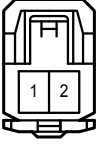

F 45
White

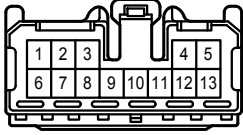

4Q
White

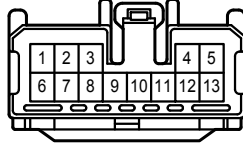

6A
White

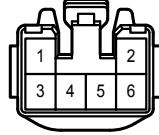

Power Source

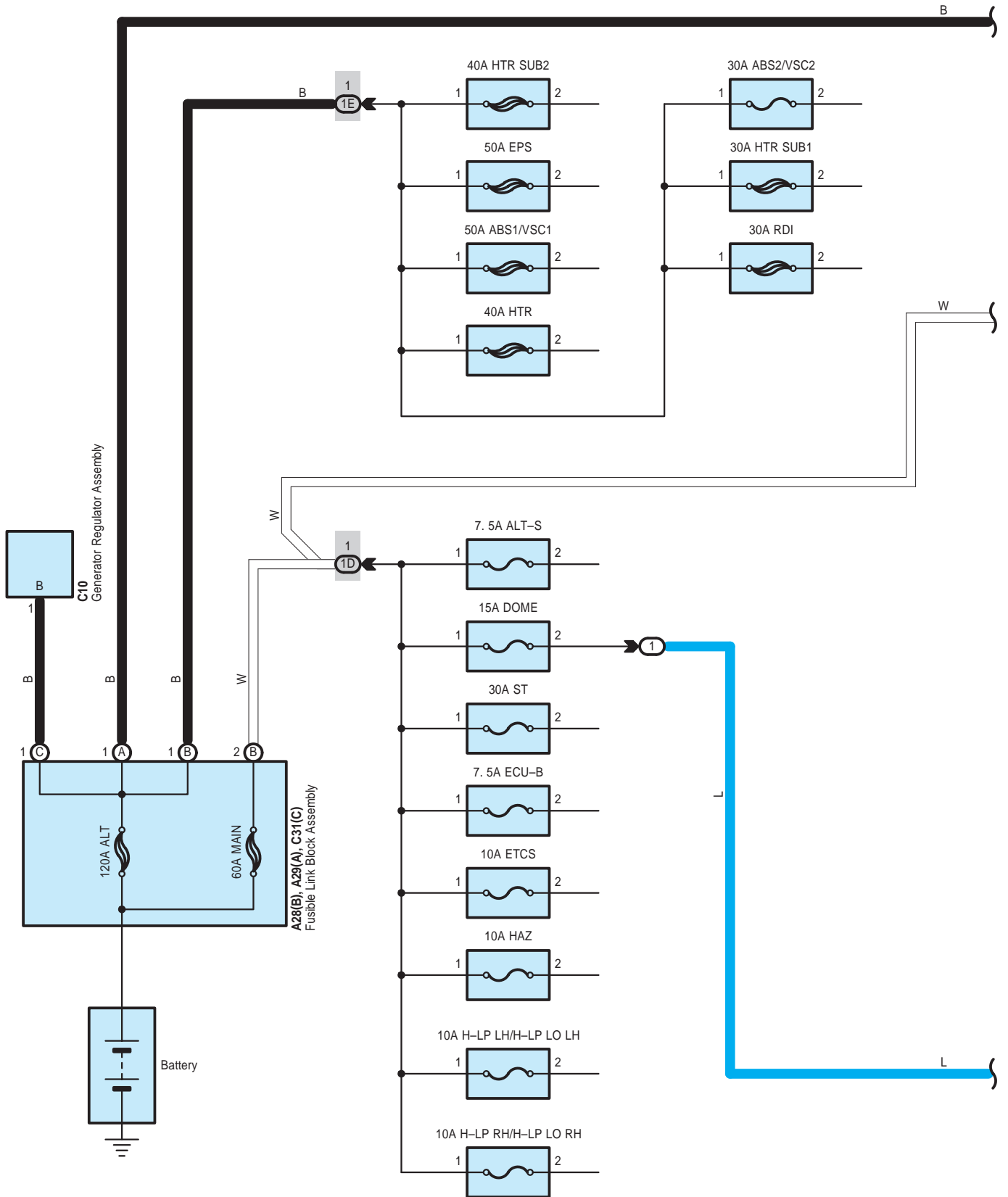

Power Source

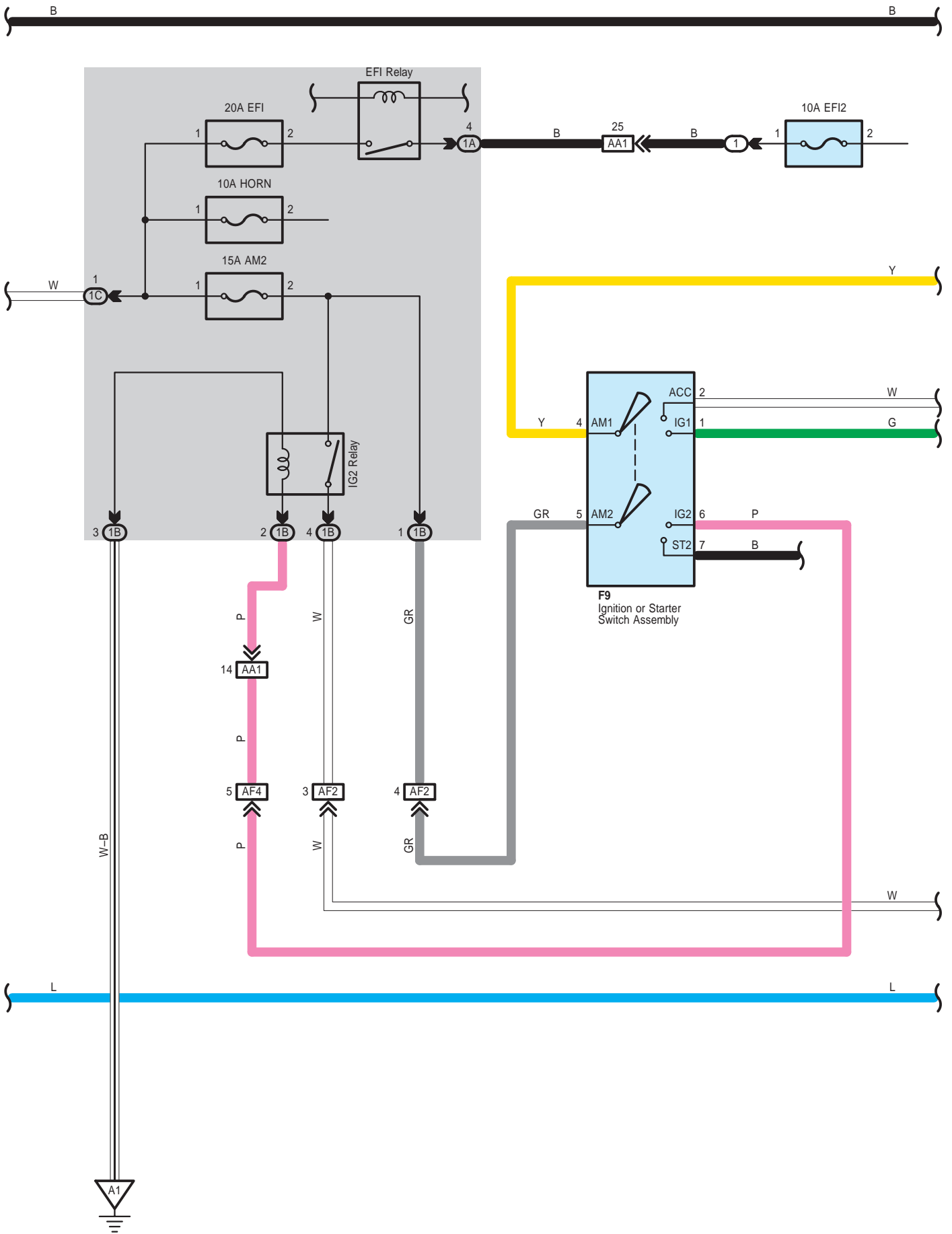

Power Source

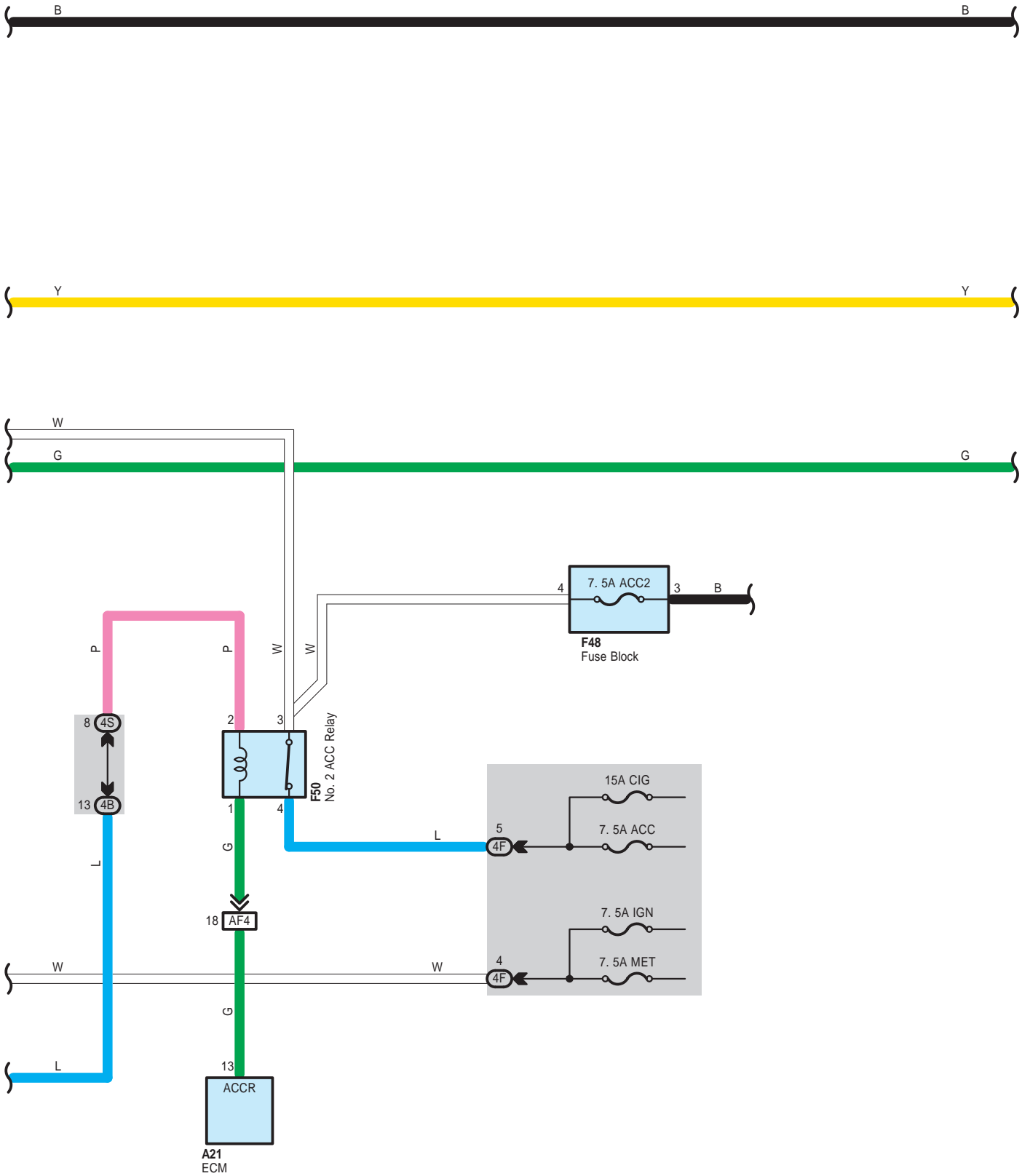

Power Source

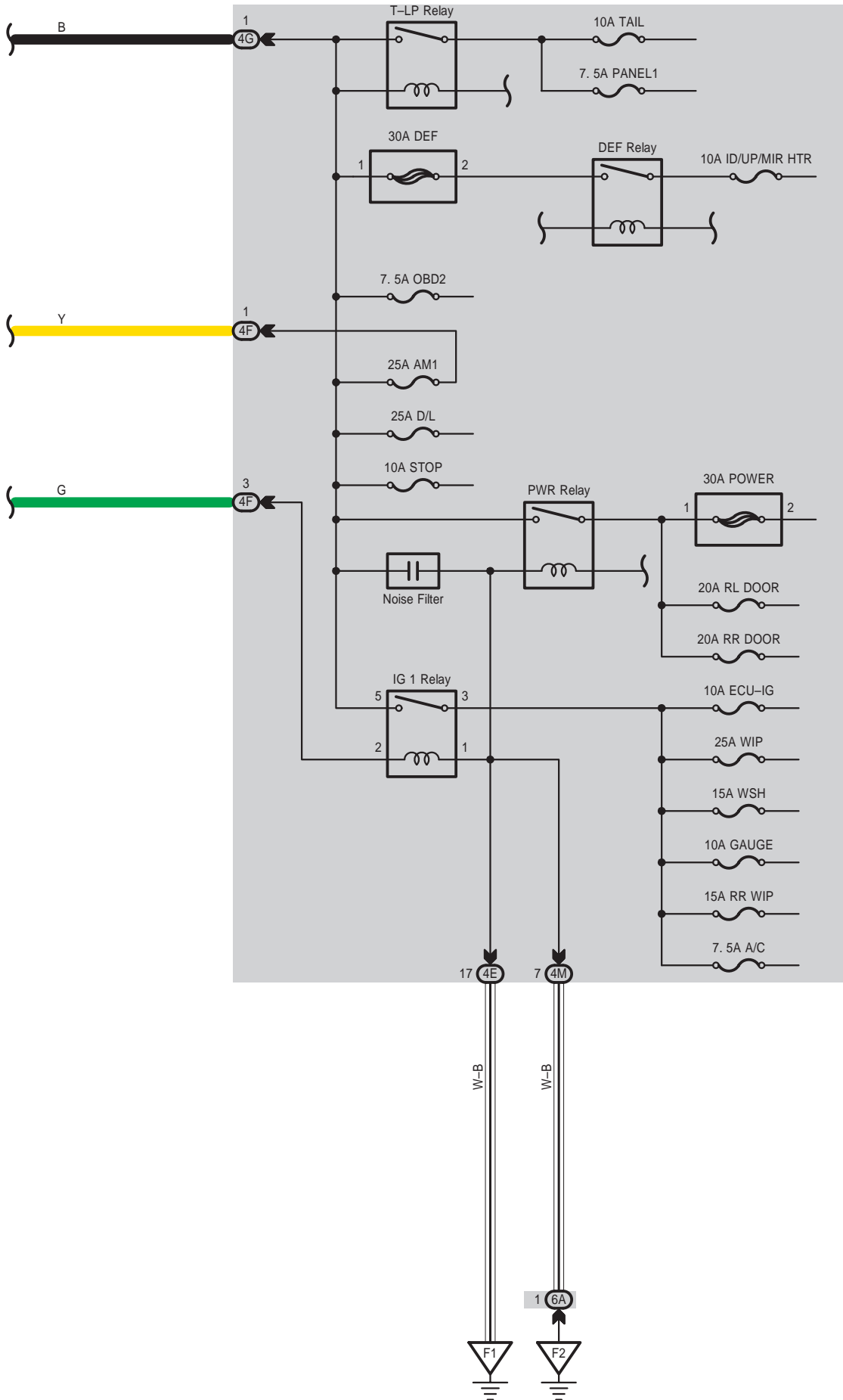

Power Source

A 21
Black

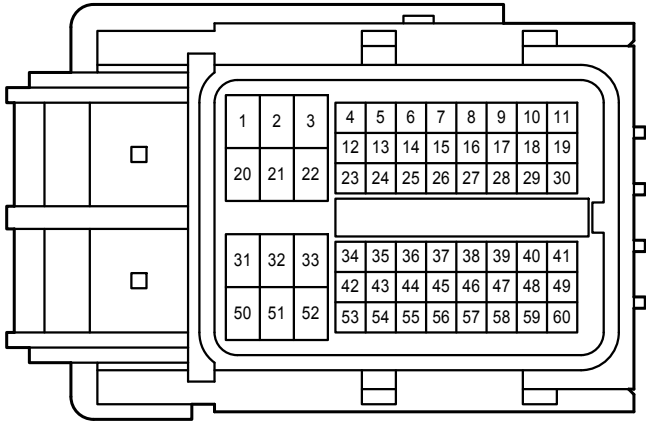

A 28
Black

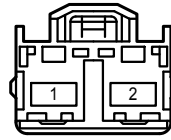

A 29
White



C 10

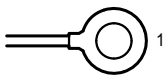

C 31



F 9
White

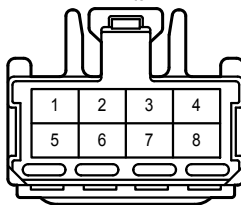

F 48
White

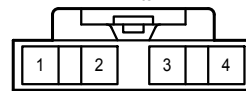

F 50
Gray

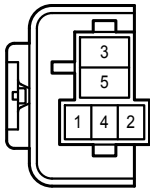

1A
White

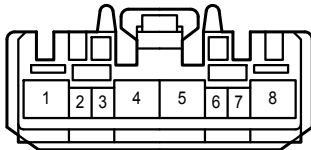

1B
White

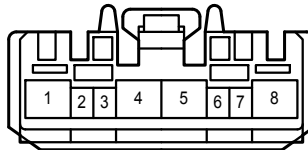

1C
White



1D

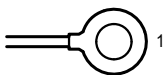

1E

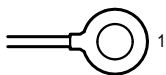

4B
White

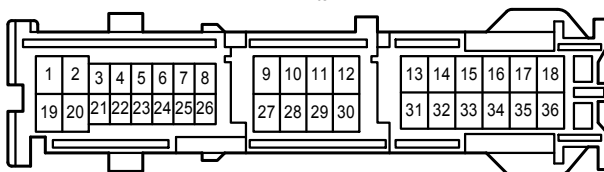

4E
White

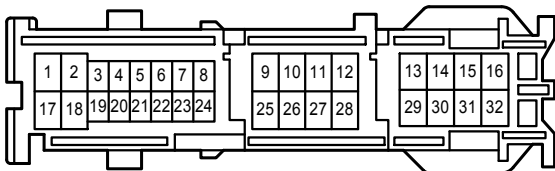

4F
White

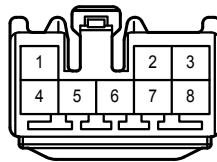

4G
White

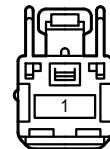

4M
White

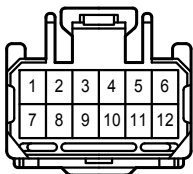

4S
White

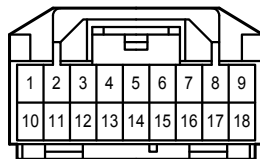

6A
White

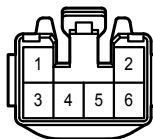

Power Source

AA1
White

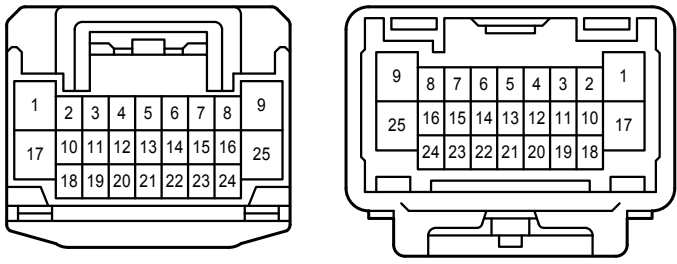

AF2
White

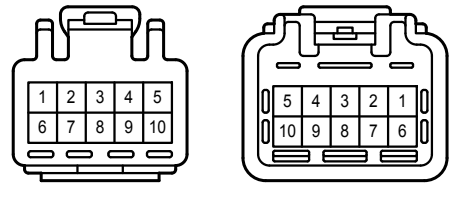

AF4
Gray

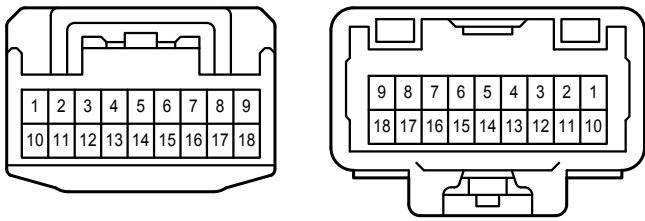

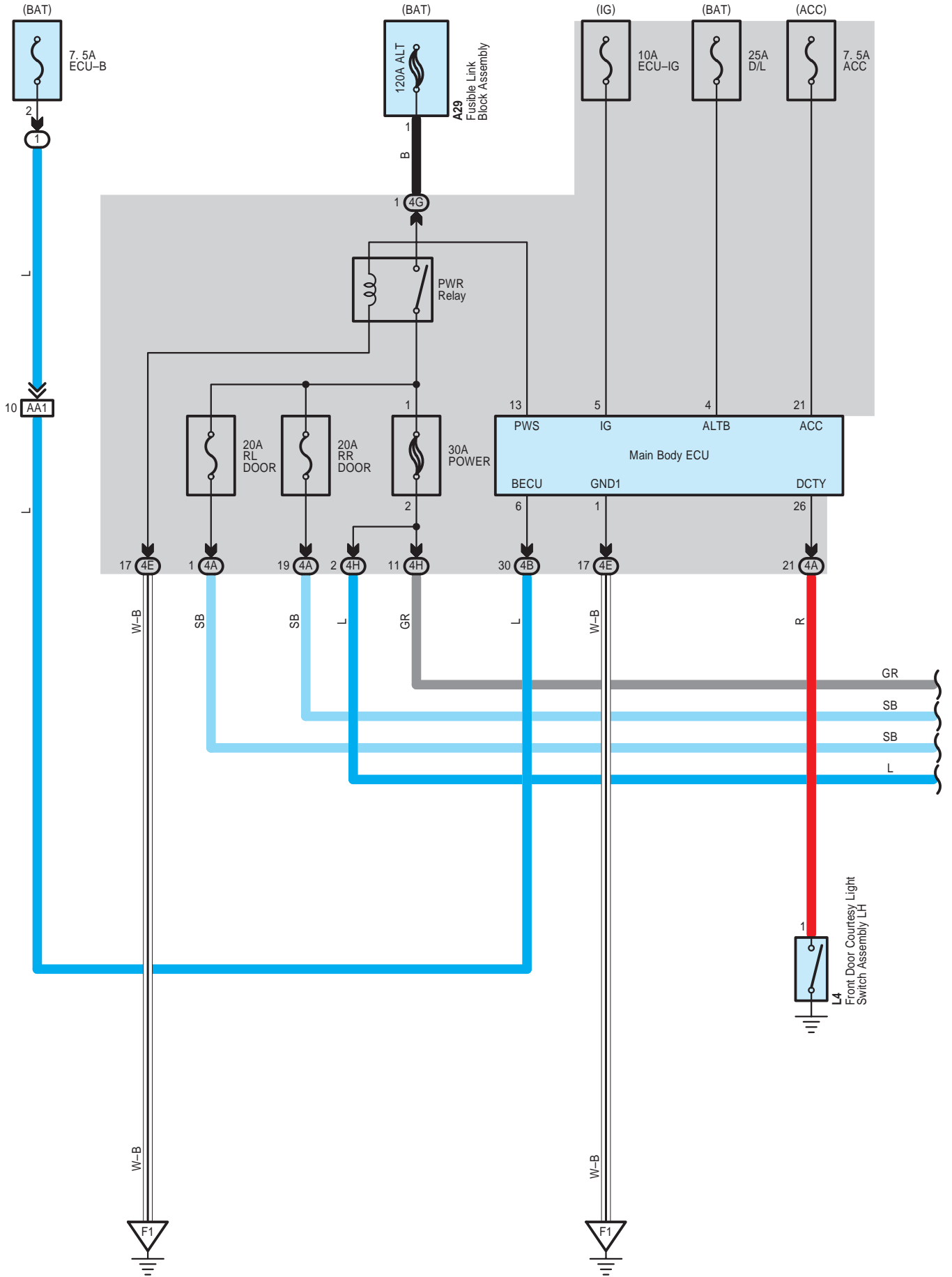

Power Window

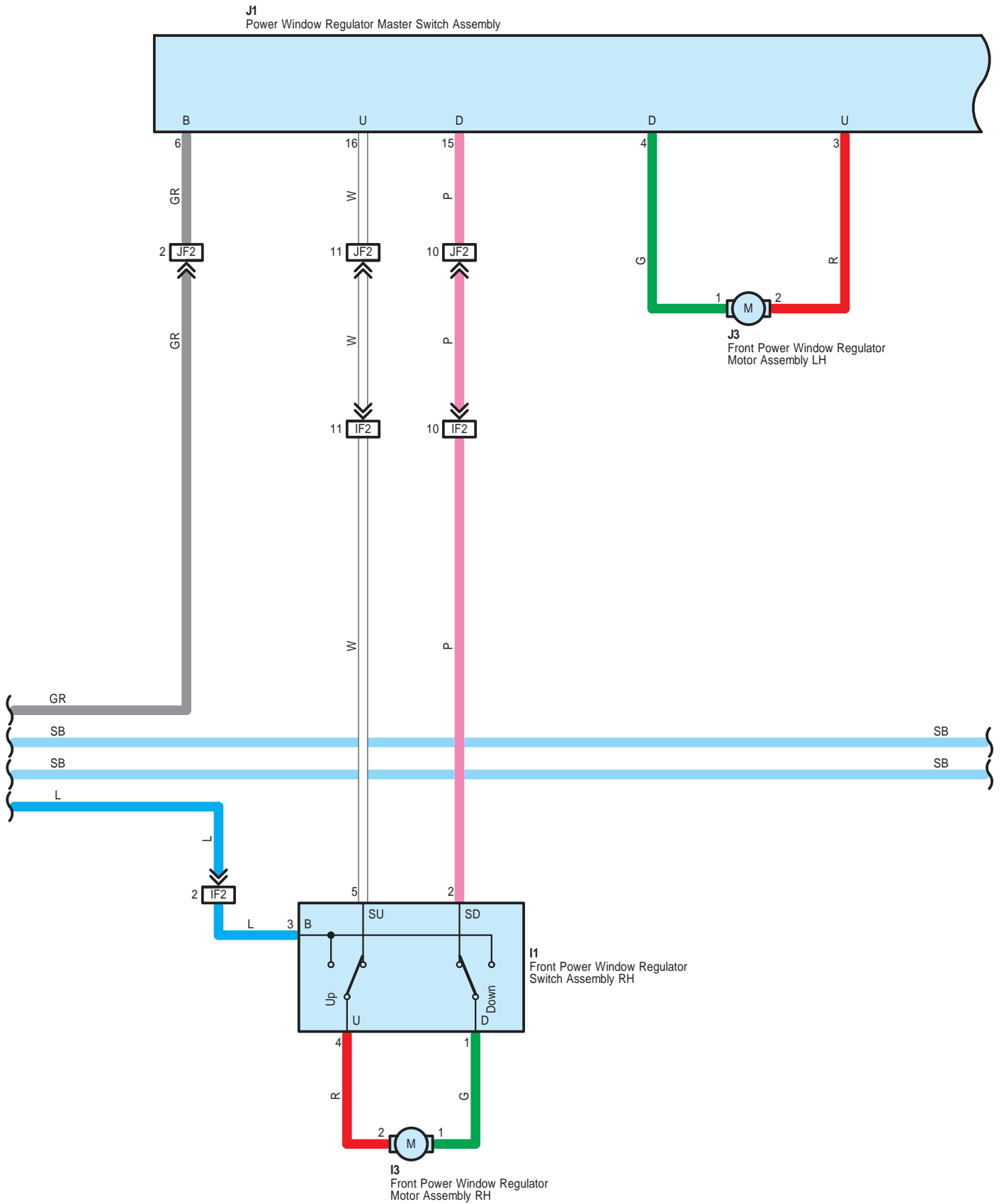

J1
Power Window Regulator Master Switch Assembly

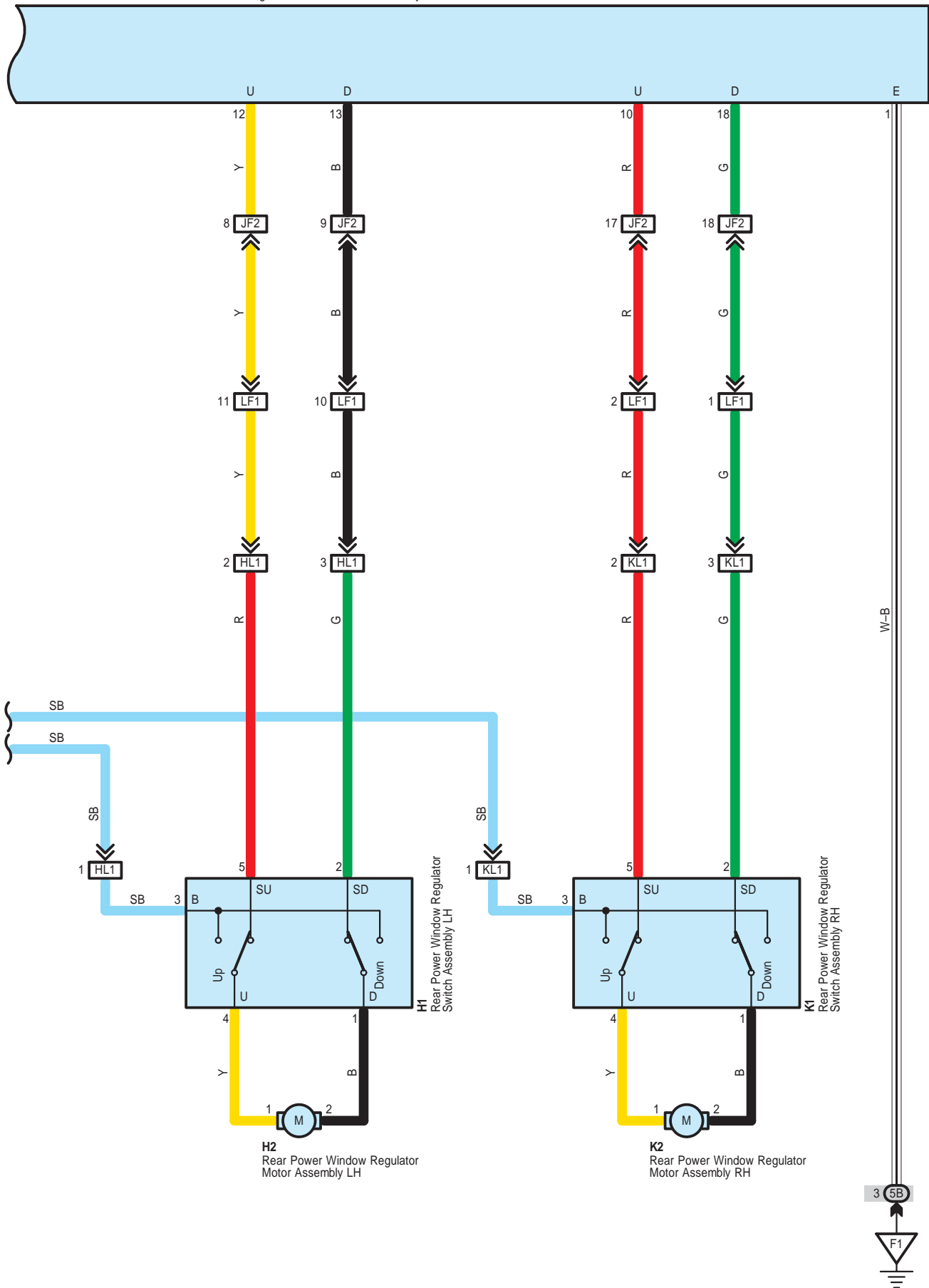

Power Window

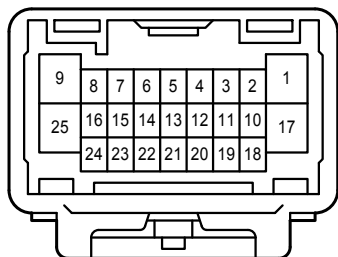
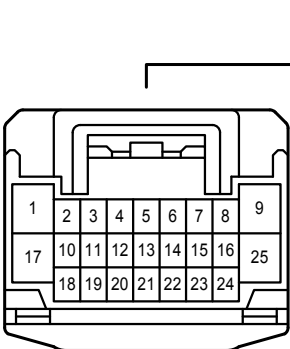
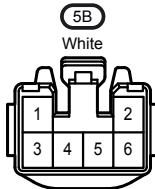
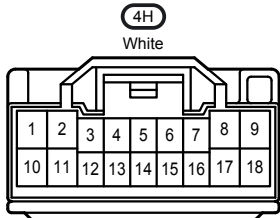
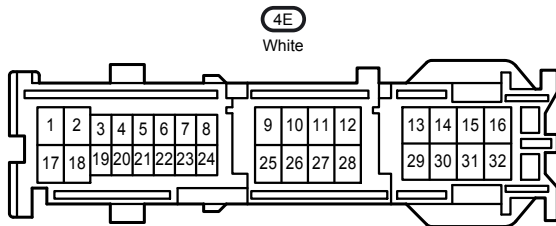
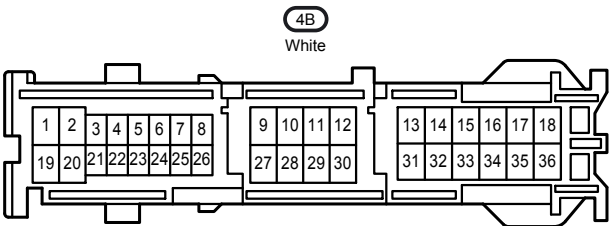
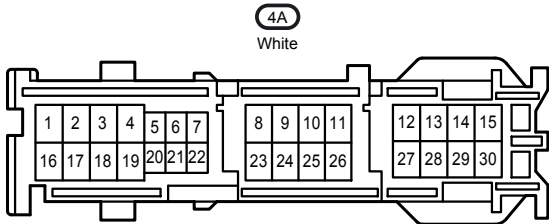
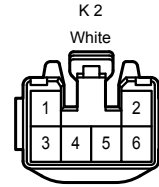
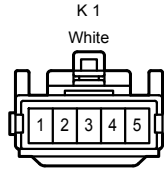
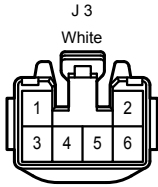
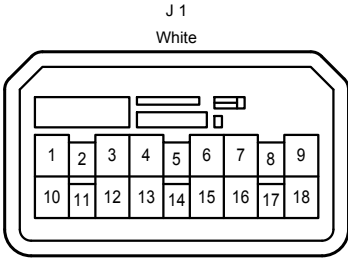
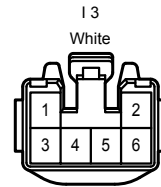
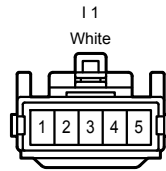
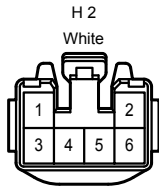
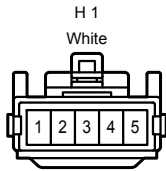
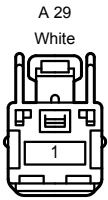

HL1
White

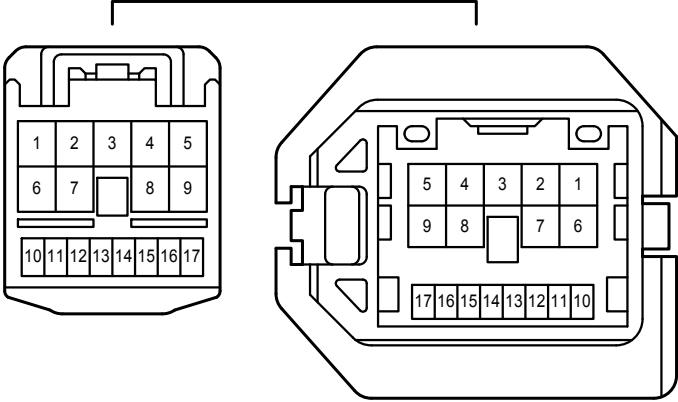

IF2
White

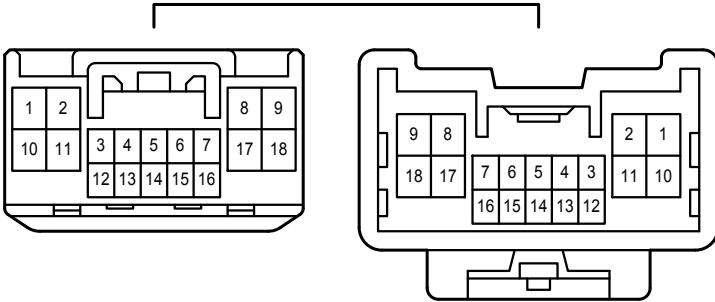

JF2
White

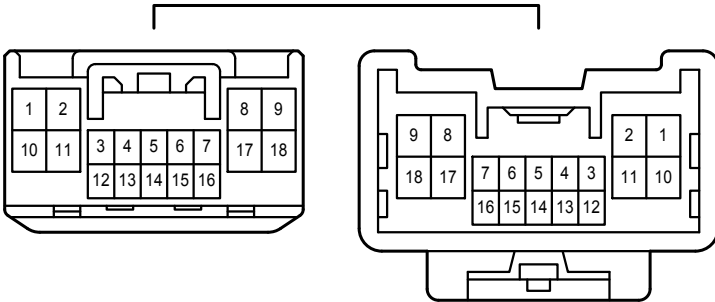

KL1
White

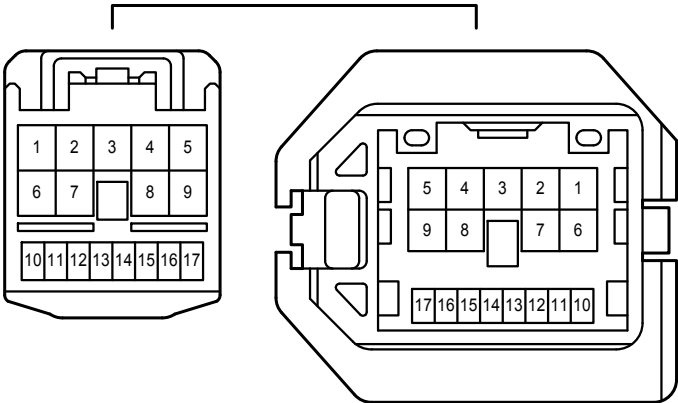

LF1
White

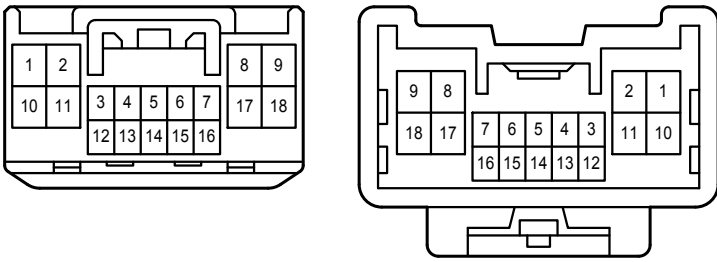

Rear Window Defogger

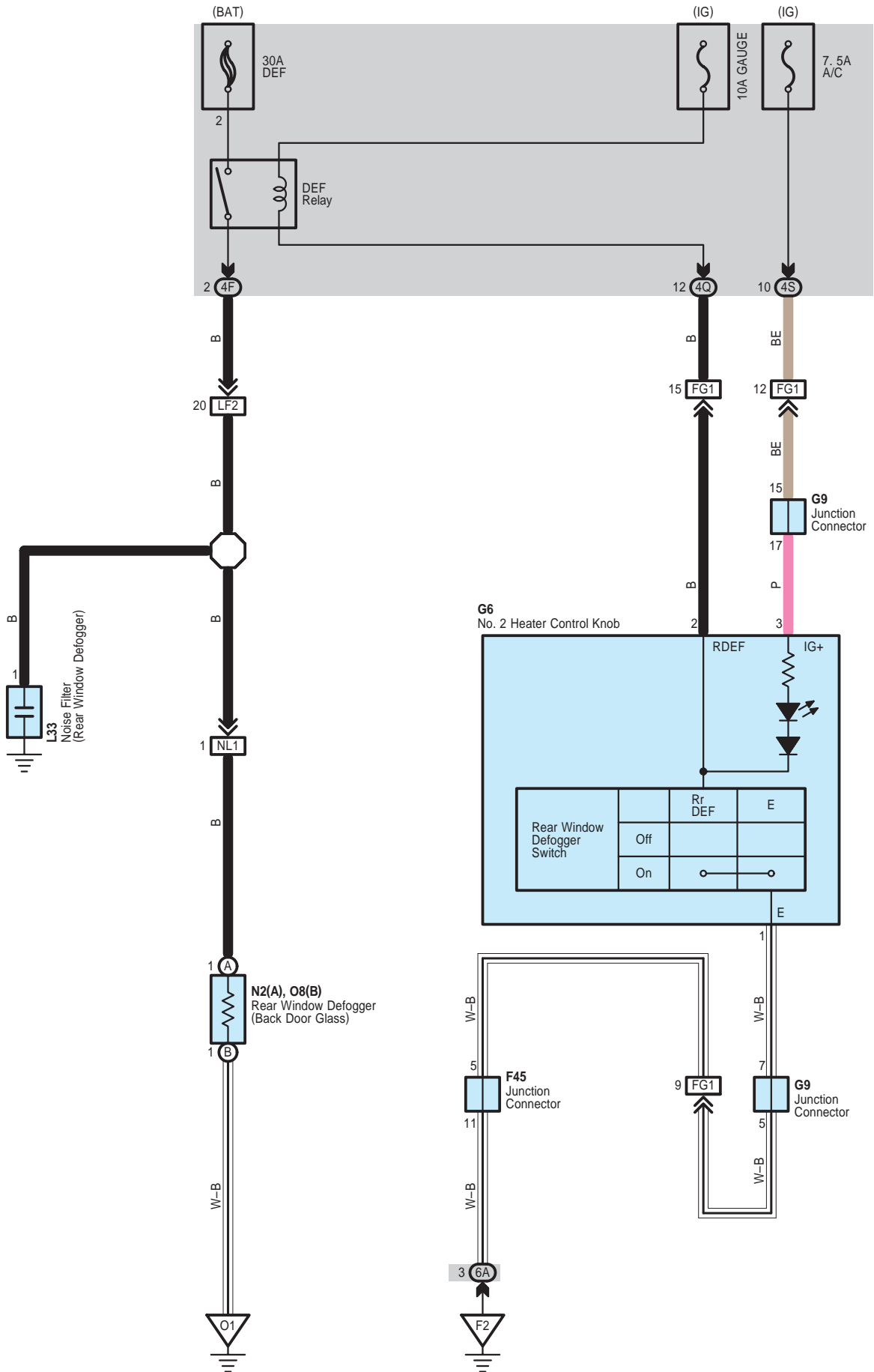

Rear Window Defogger

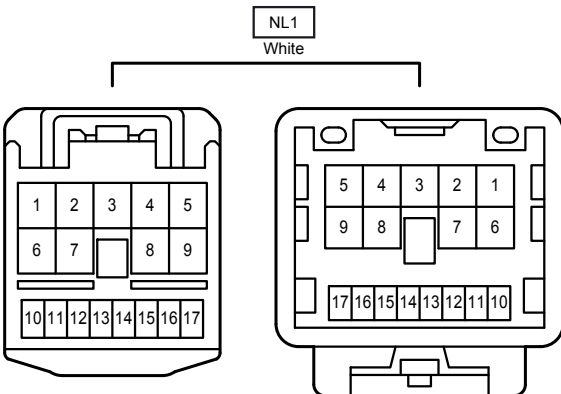
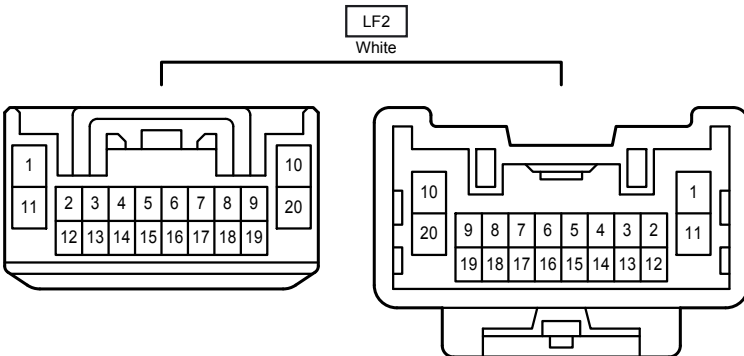
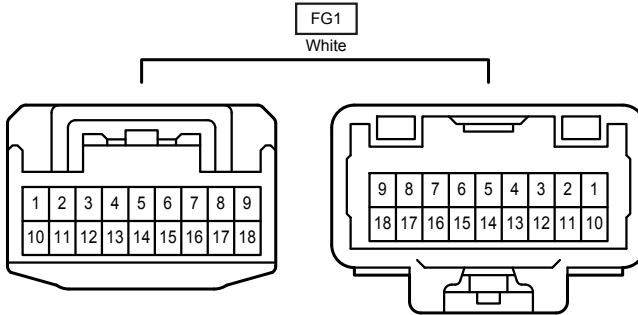
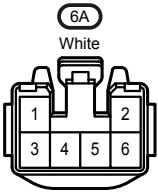
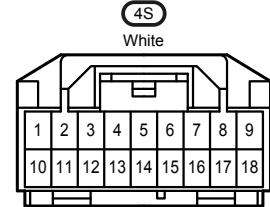
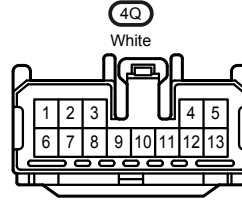
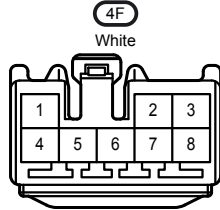
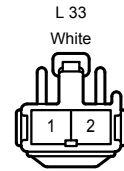
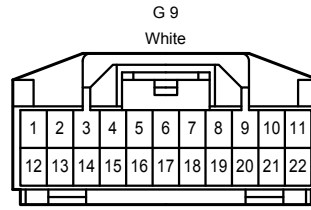
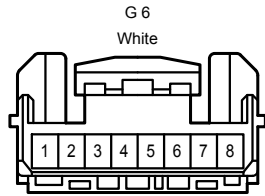
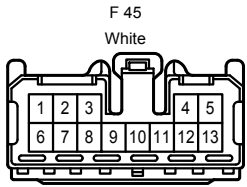

Rear Wiper and Washer

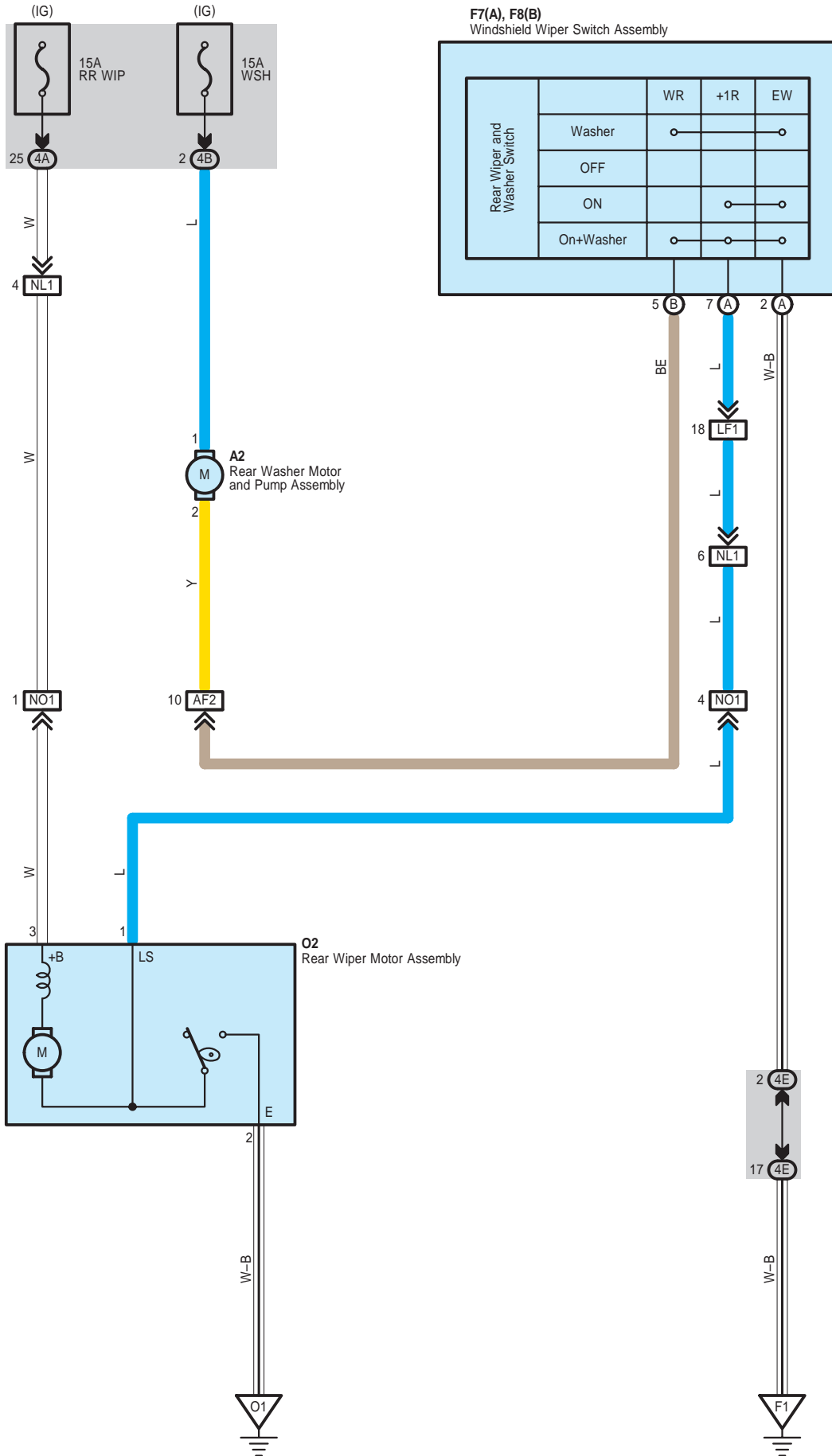

Rear Wiper and Washer

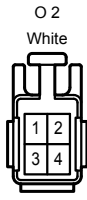
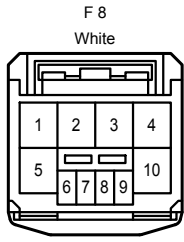
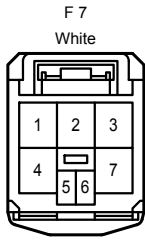
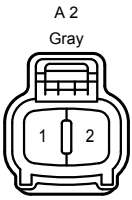

4A
White

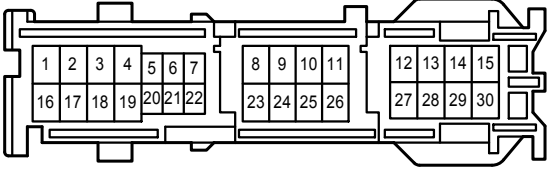

4B
White

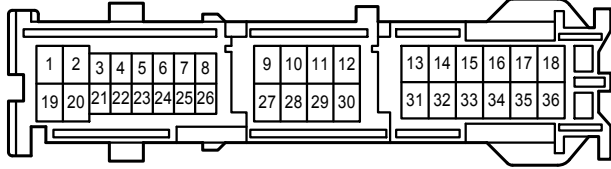

4E
White

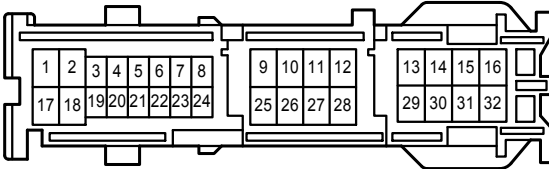

AF2
White

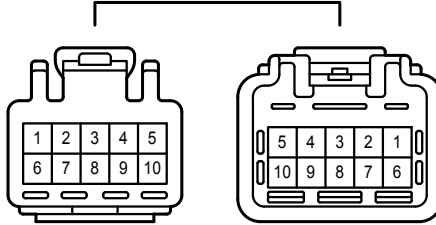

LF1
White

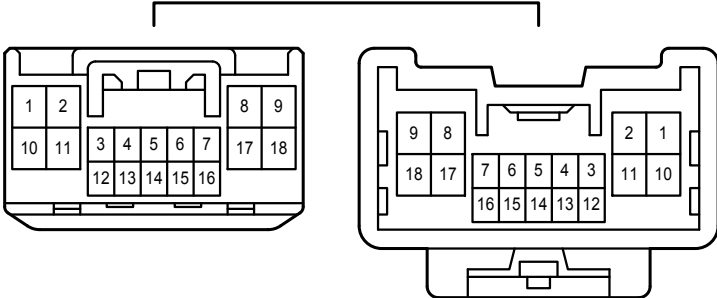

NL1
White

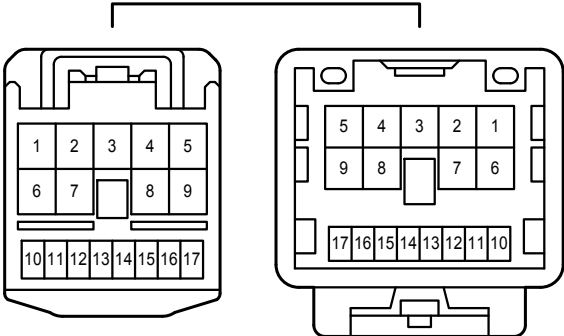

NO1
White

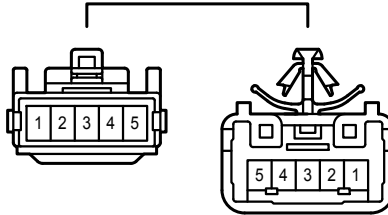

Remote Control Mirror

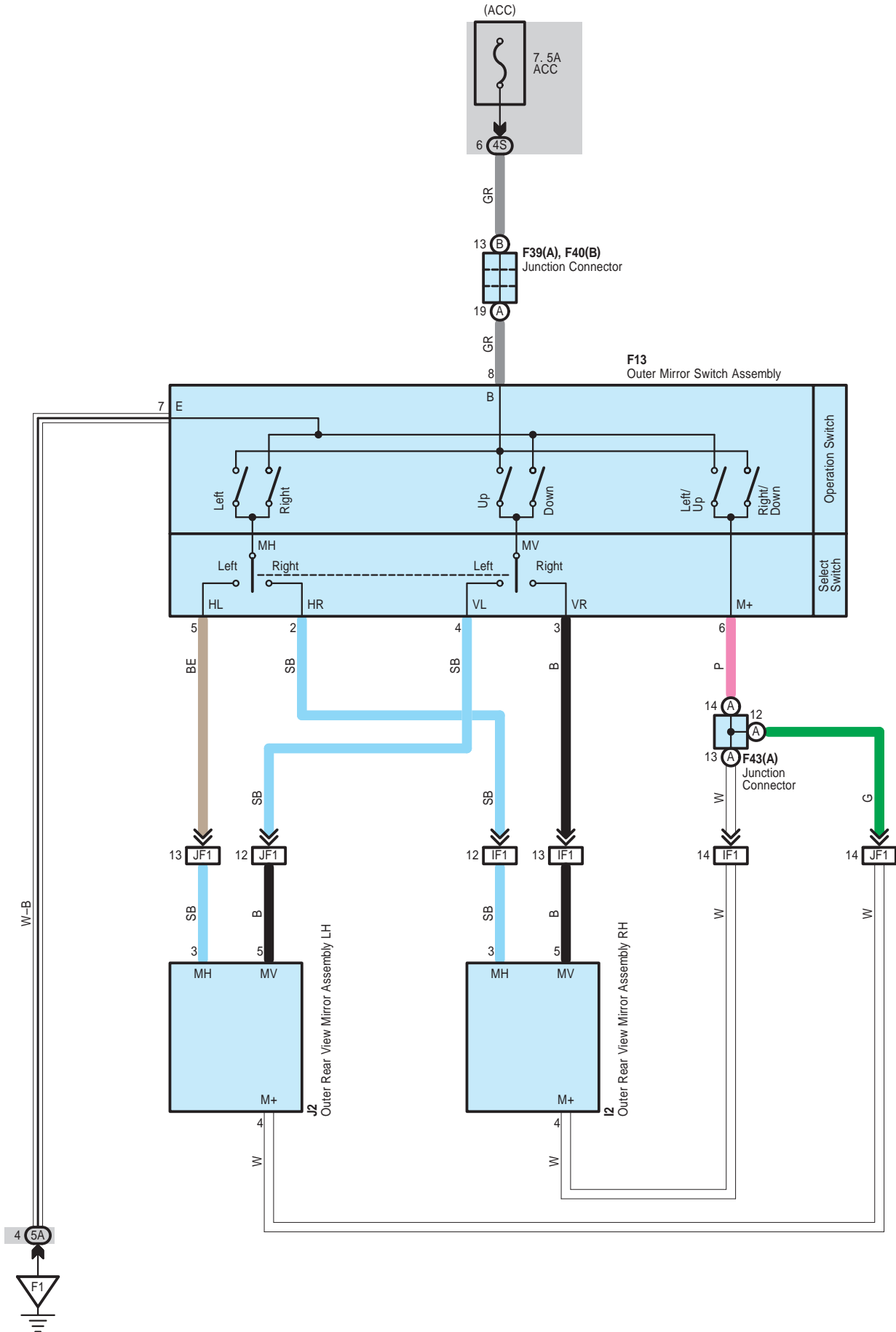

Remote Control Mirror

F 13

White

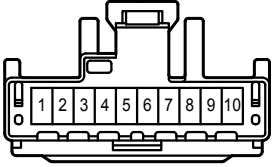

F 39

White

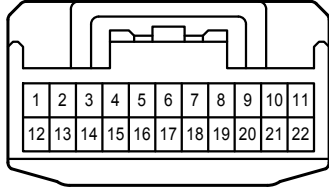

F 40

White

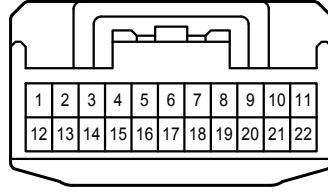

F 43

White

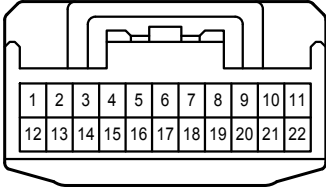

I 2

White

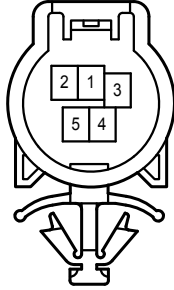

J 2

White

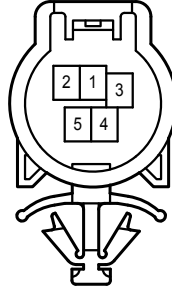

4S

White

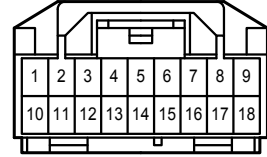

5A

White

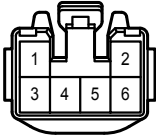

IF1

White

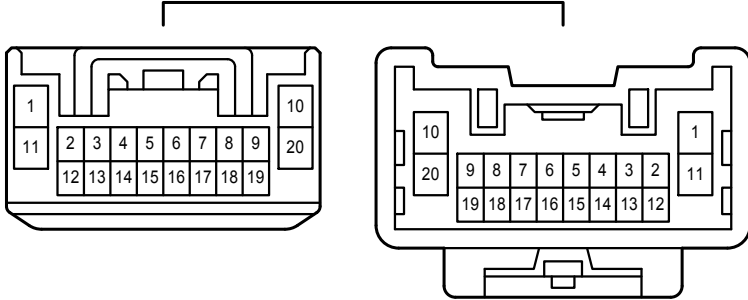

JF1

White

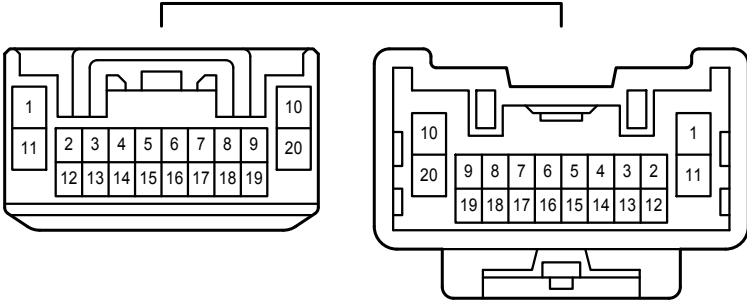

Seat Belt Warning

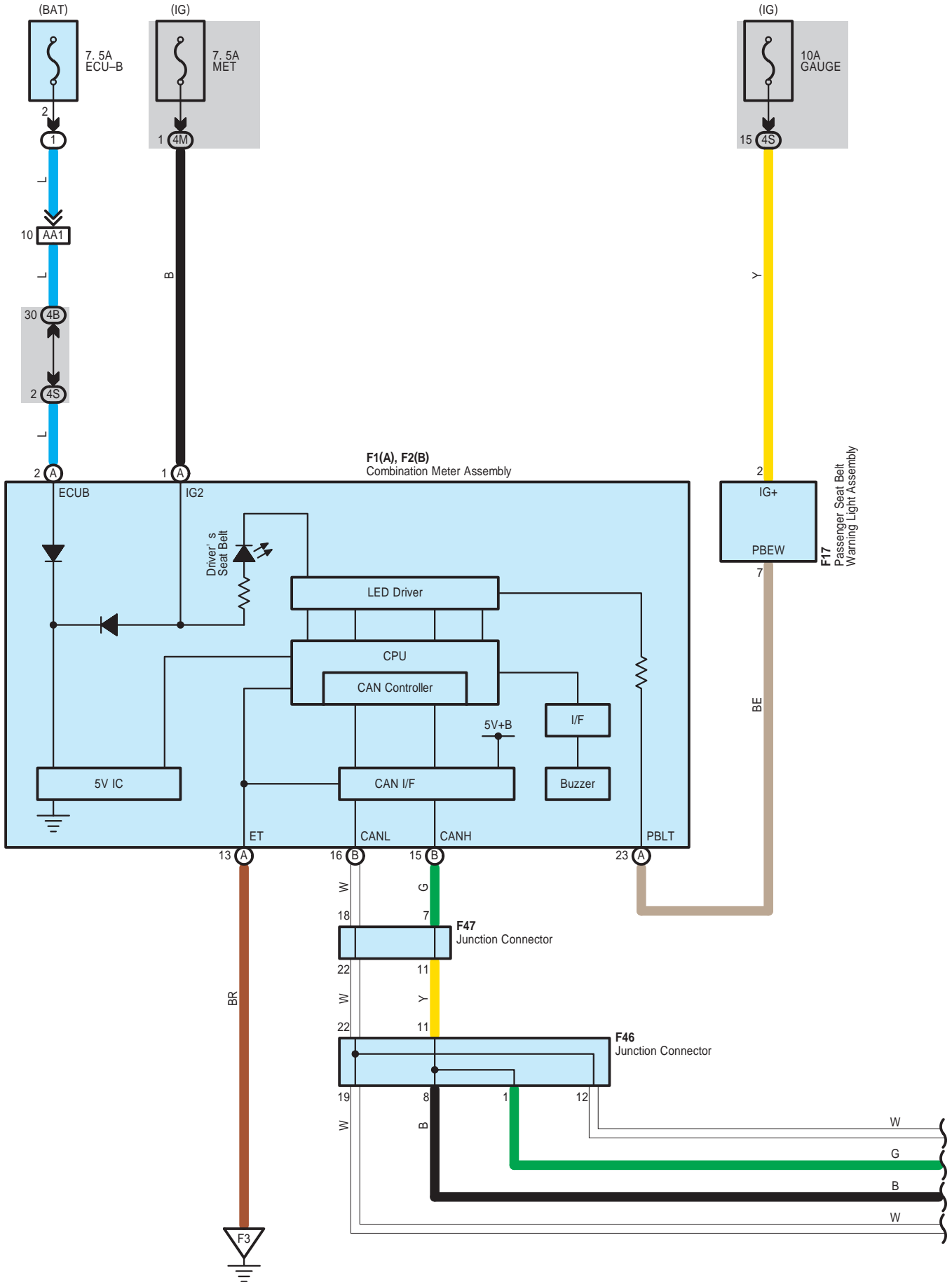

Seat Belt Warning

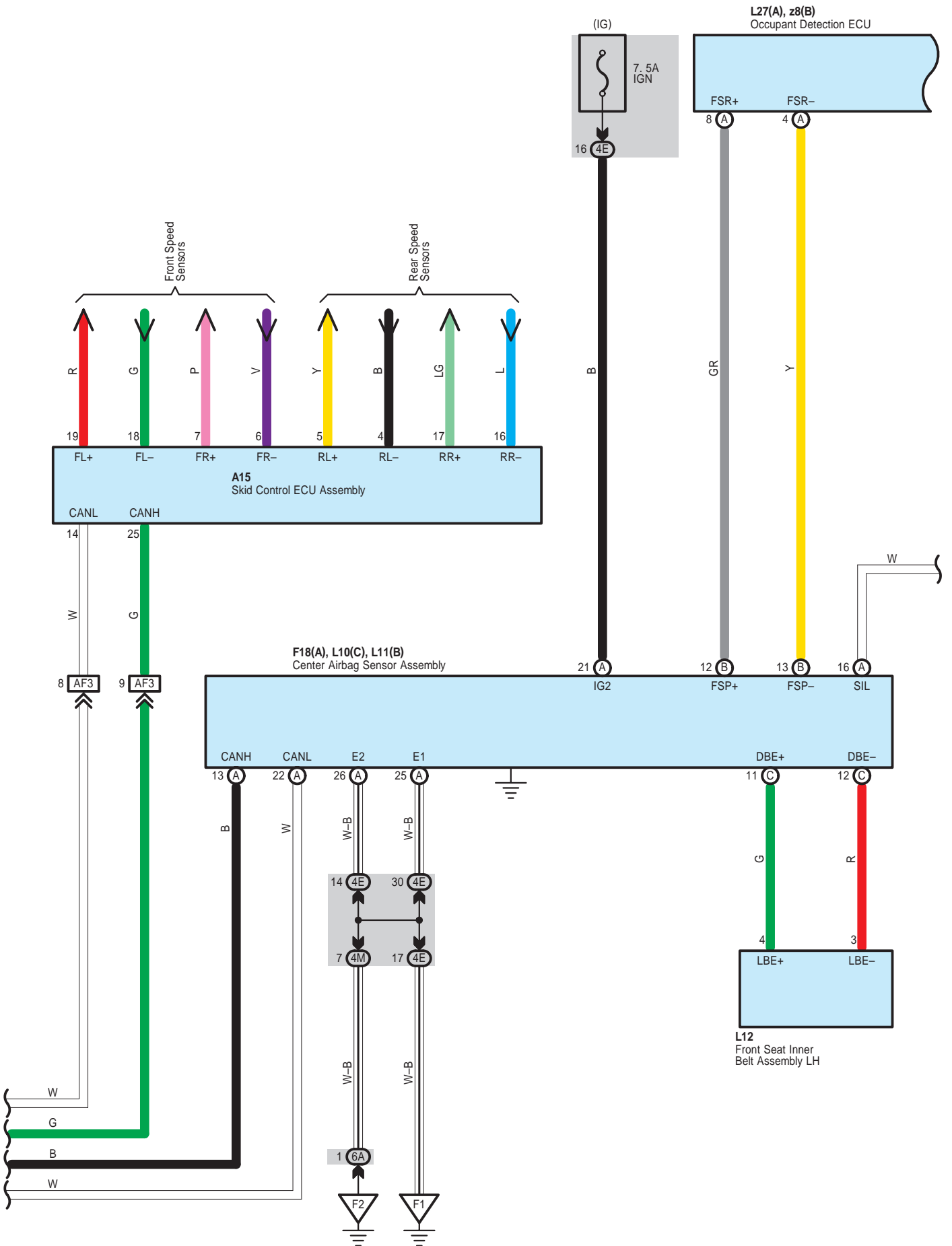

Seat Belt Warning

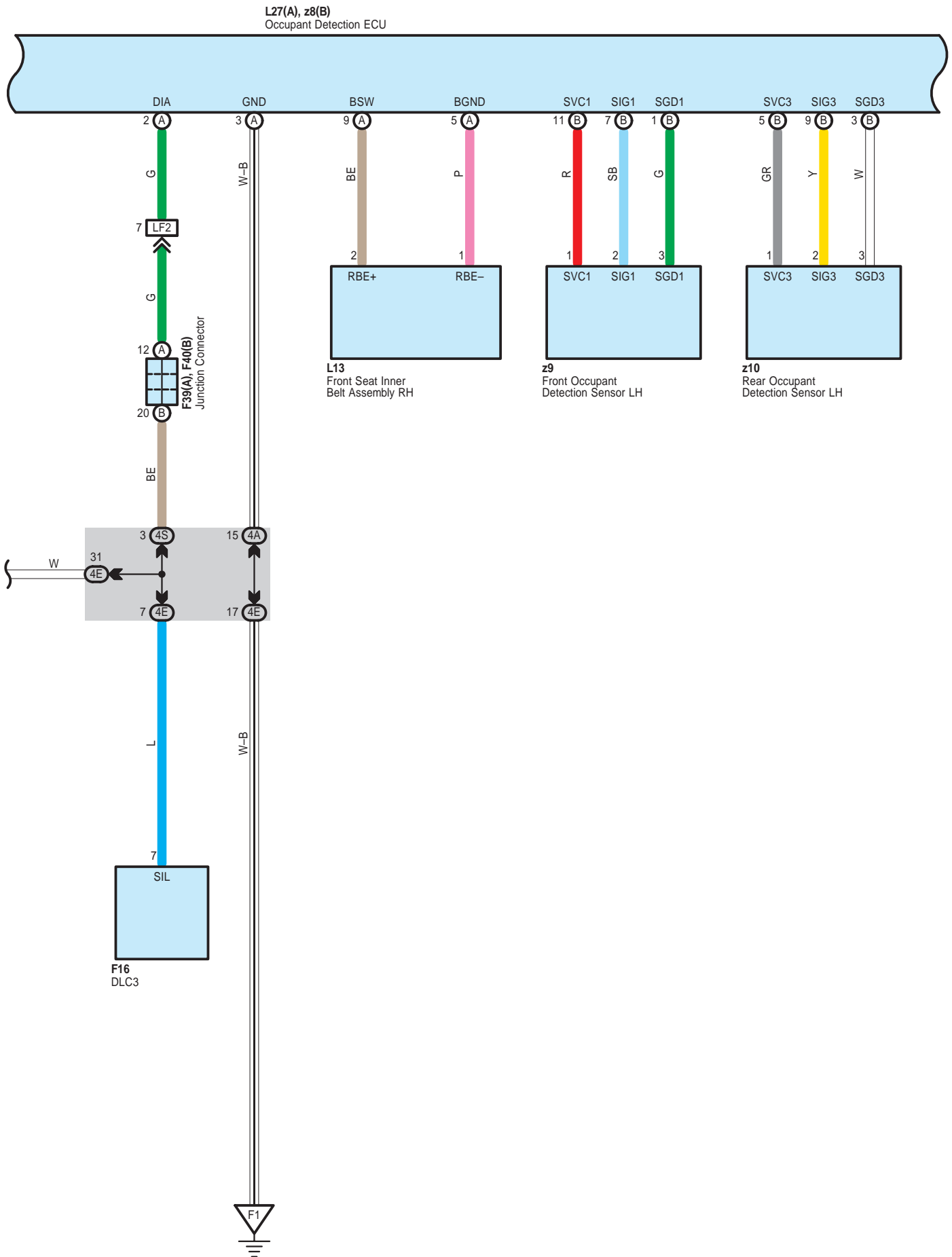

Seat Belt Warning

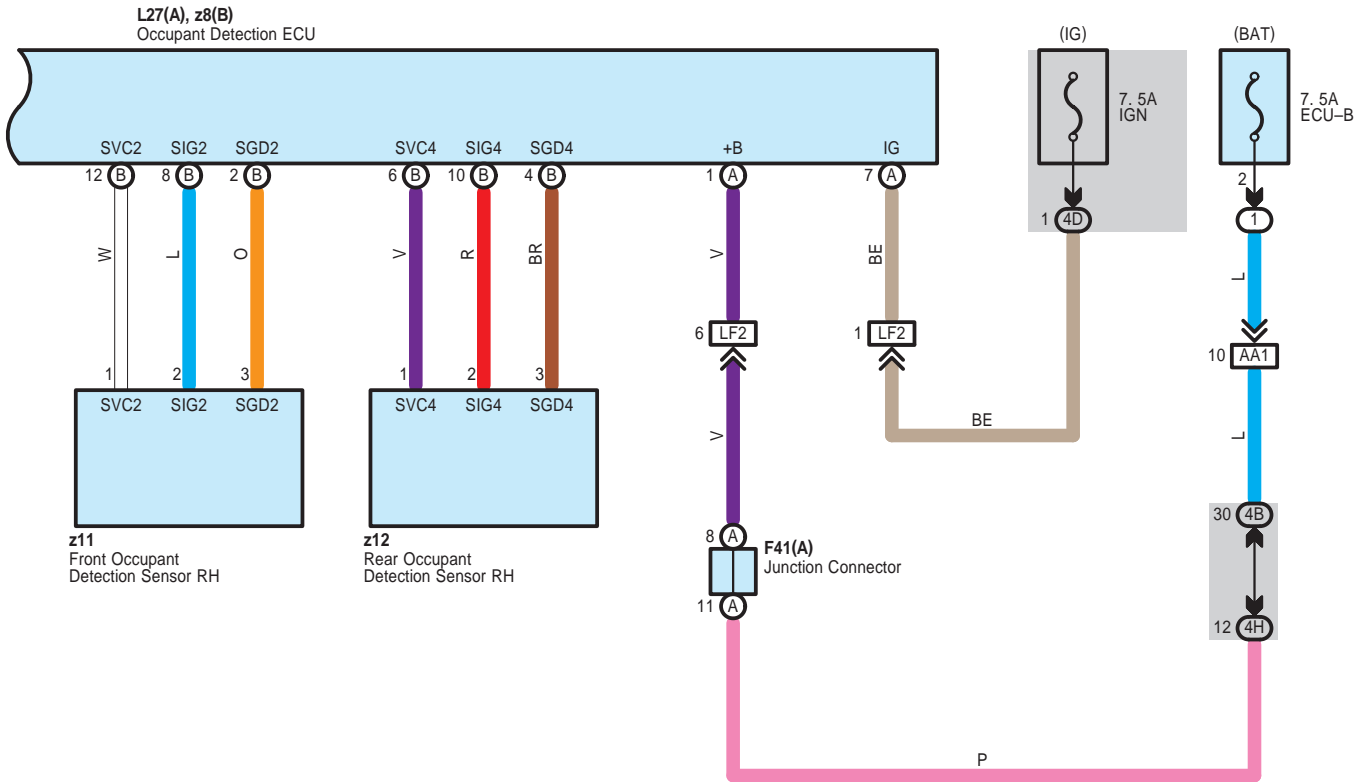

Seat Belt Warning

A 15
Black

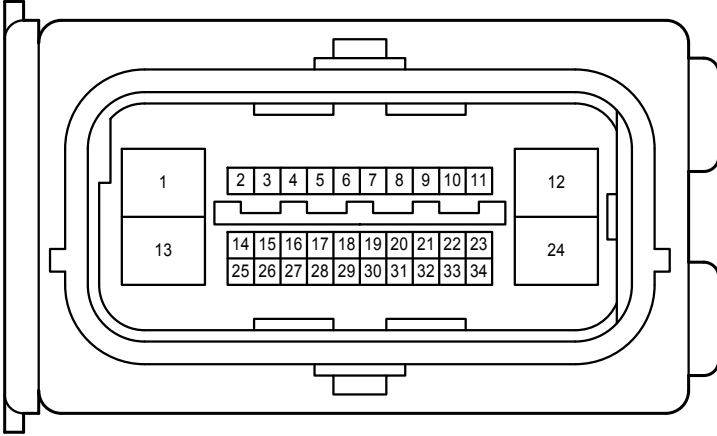

F 1
White

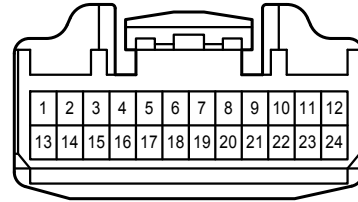

F 2
White

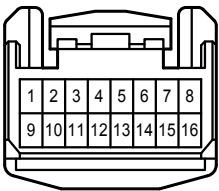

F 16
White

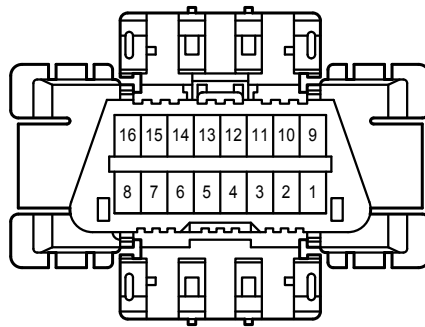

F 17
White

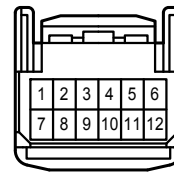

F 18
Yellow

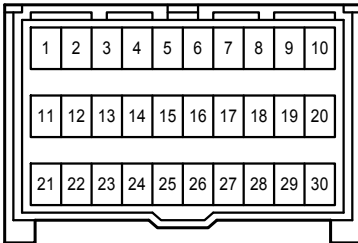

F 39
White

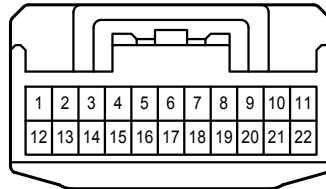

F 40
White

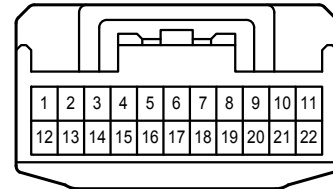

F 41
White

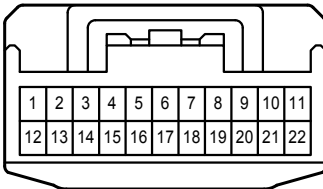

F 46
White

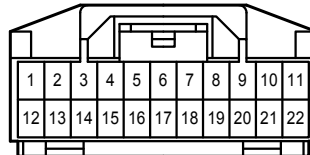

F 47
White

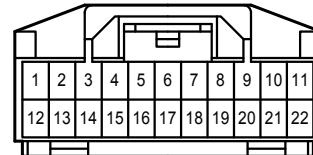

L 10
Yellow

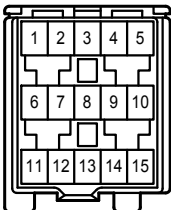

L 11
Yellow

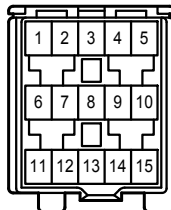

L 12
White



L 13
White

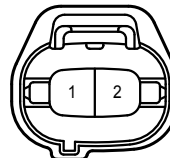

Seat Belt Warning

L 27
Black

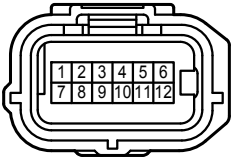

z 8
Gray

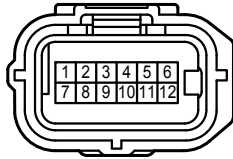

z 9
Black

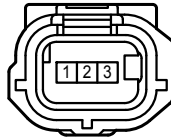

z 10
Black

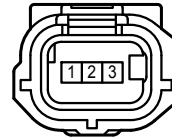

z 11
Black

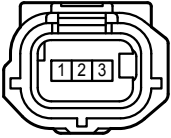

z 12
Black

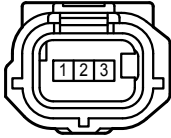

4A
White

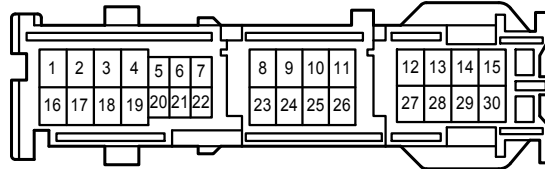

4B
White

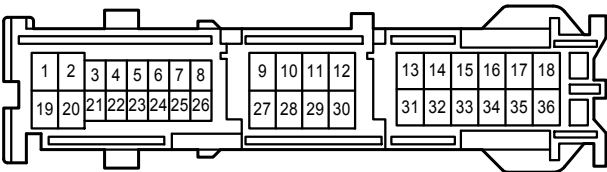

4D
White

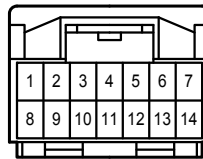

4E
White

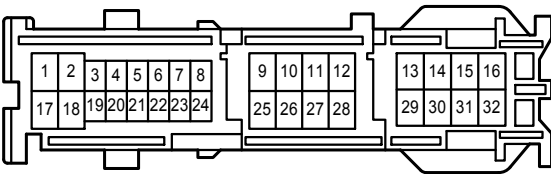

4H
White

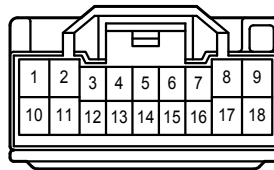

4M
White

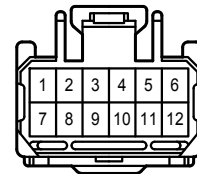

4S
White

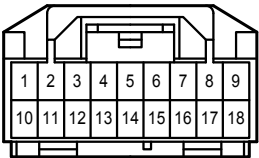

6A
White

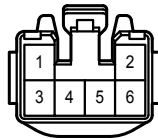

AA1
White

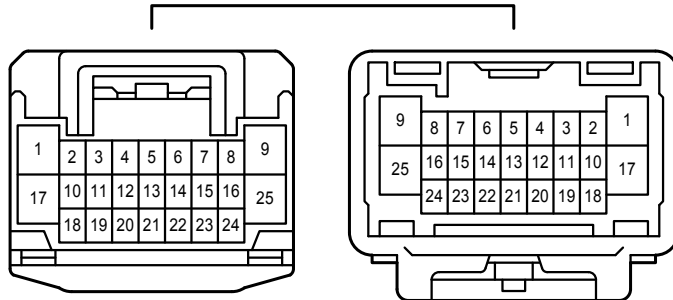

AF3
Black

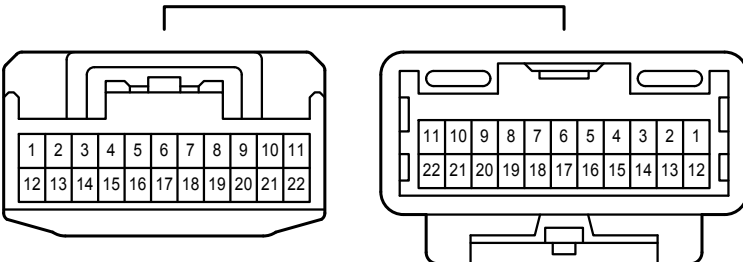

LF2
White

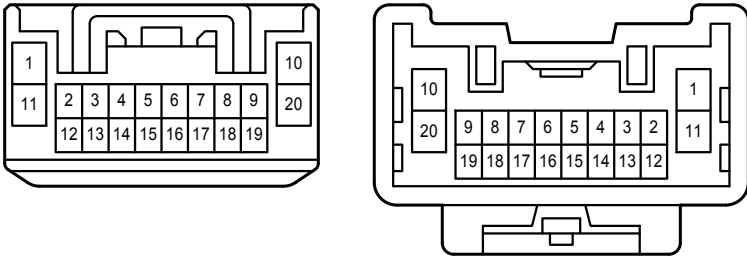

Shift Lock

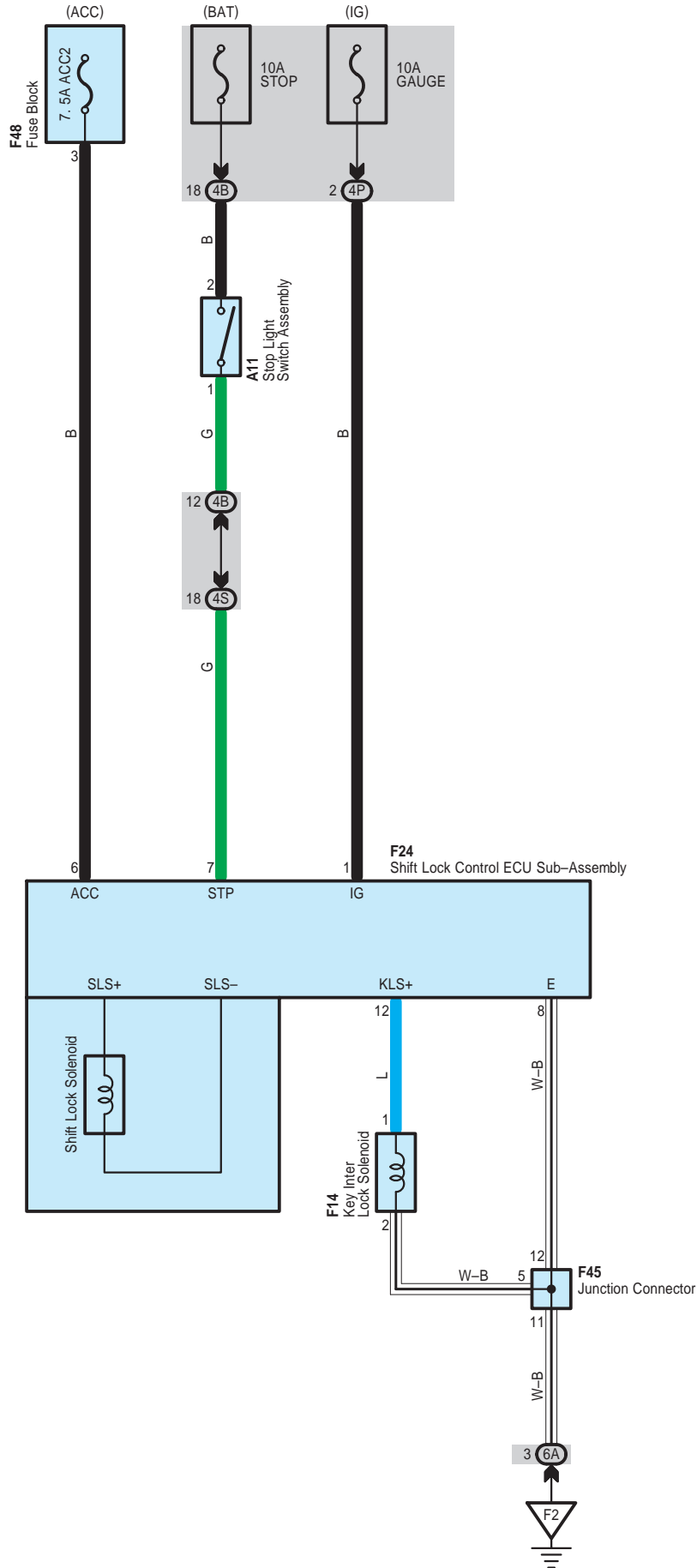

Shift Lock

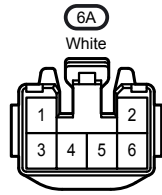
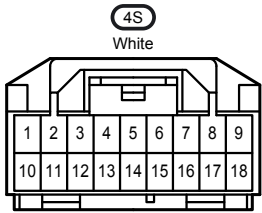
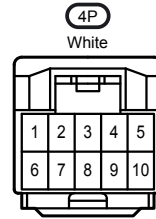
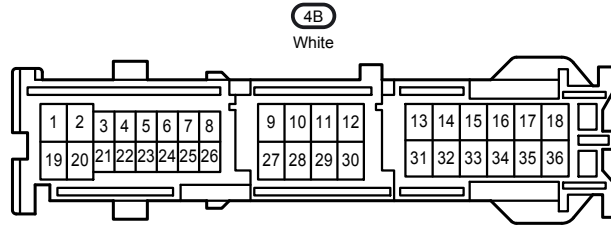
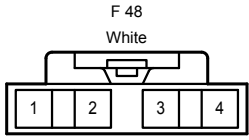
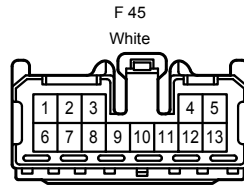
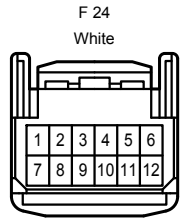
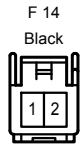
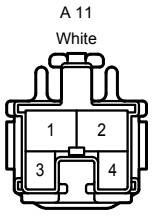

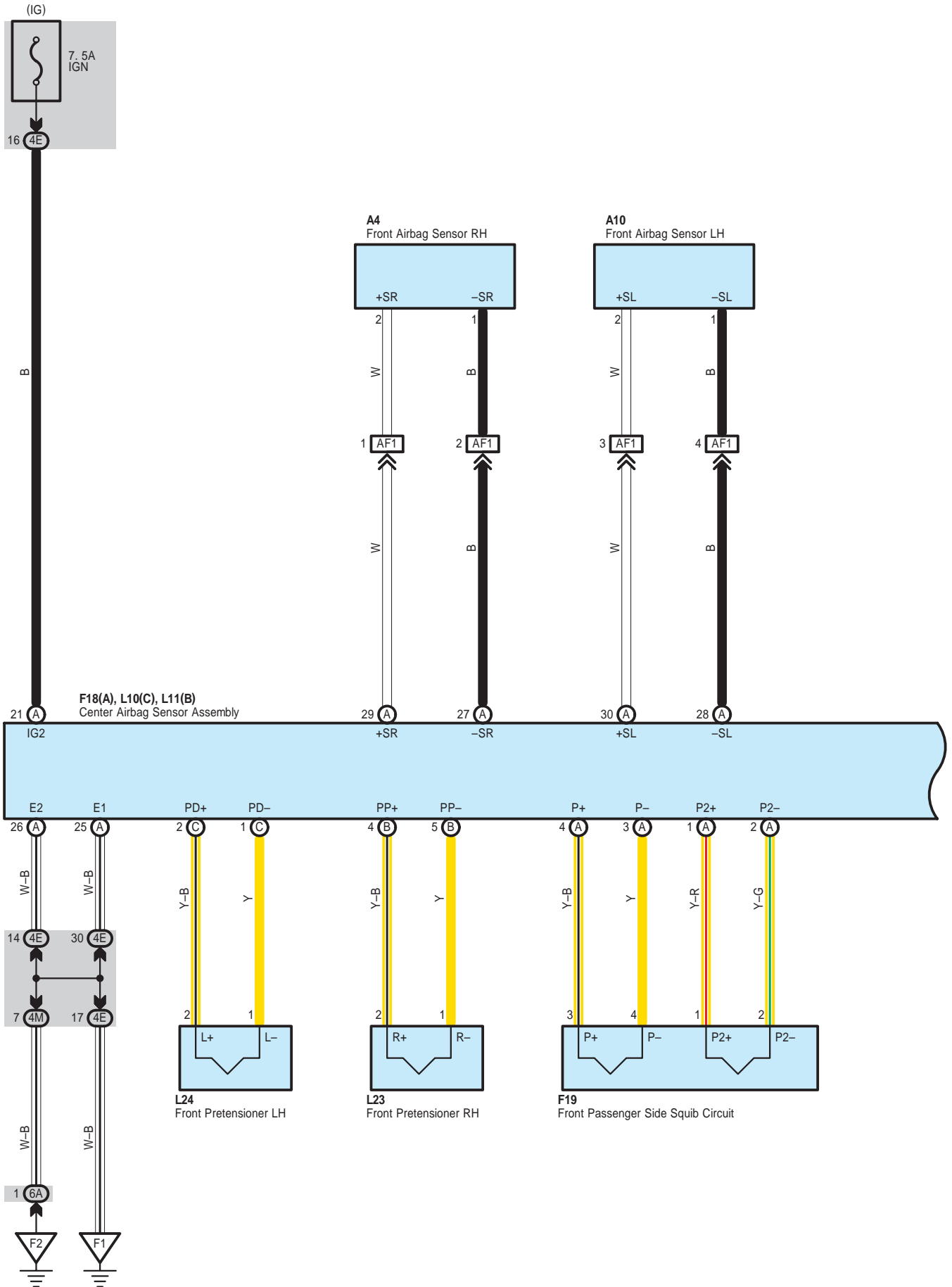

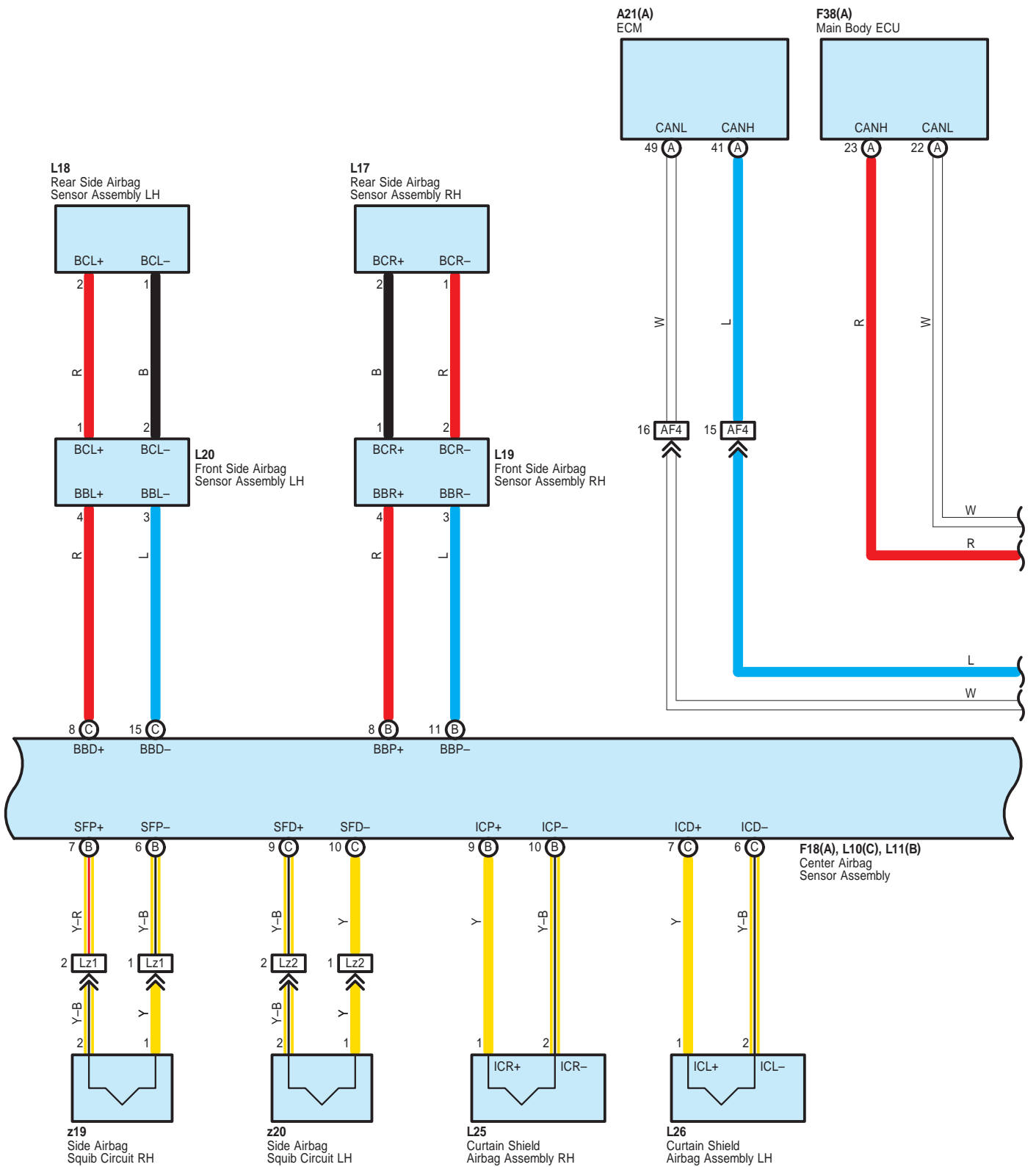

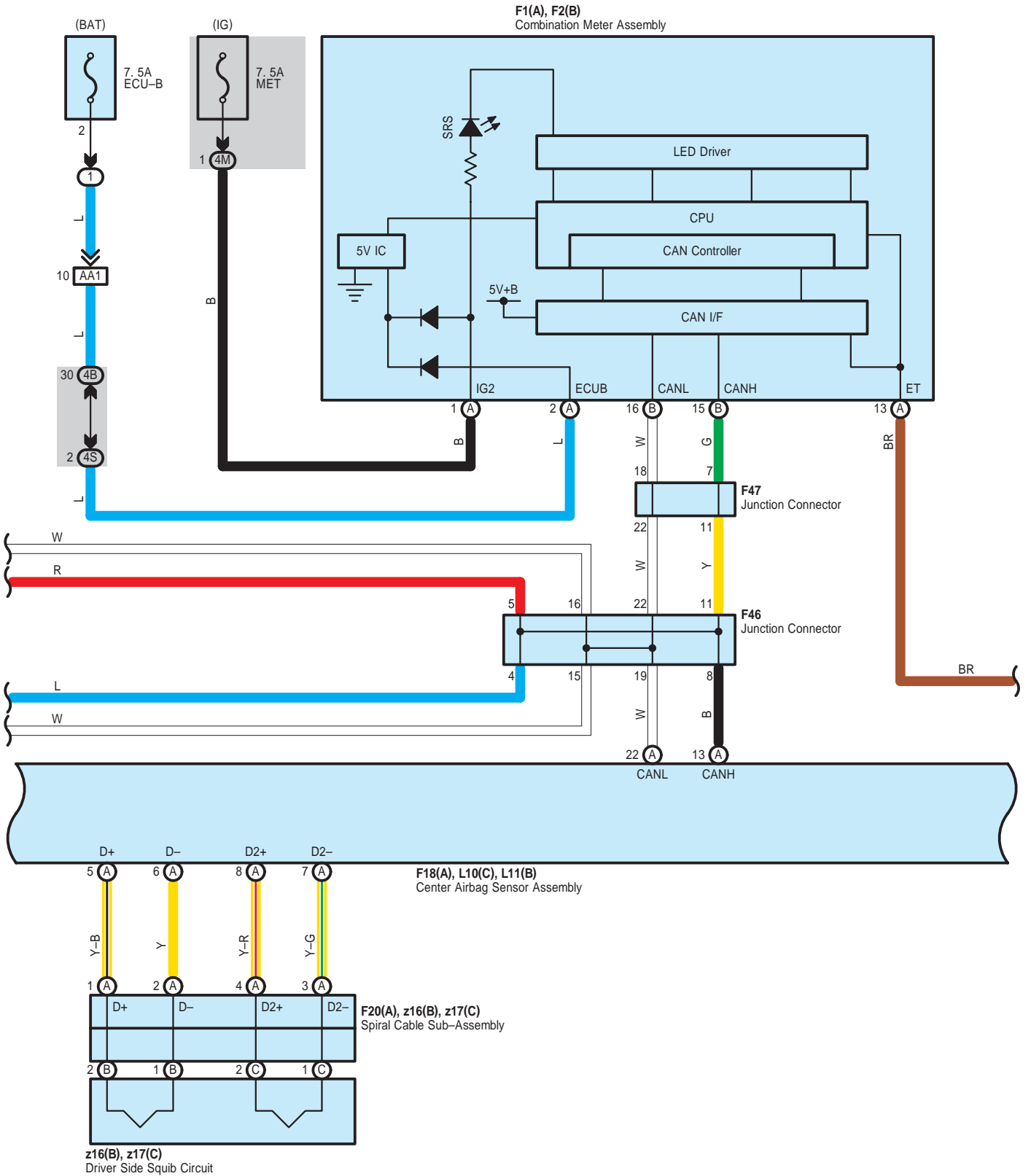

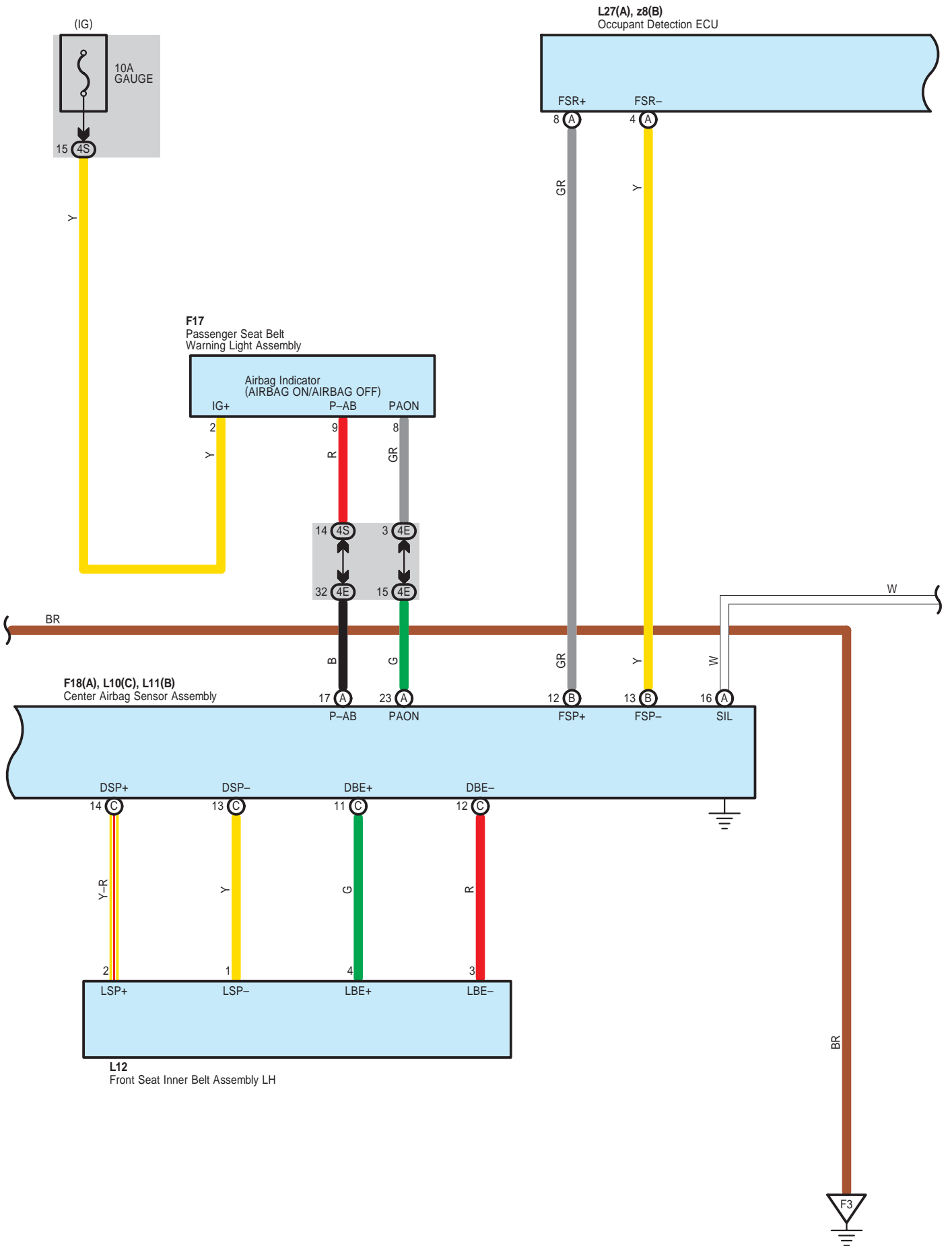

L27(A), z8(B)
Occupant Detection ECU

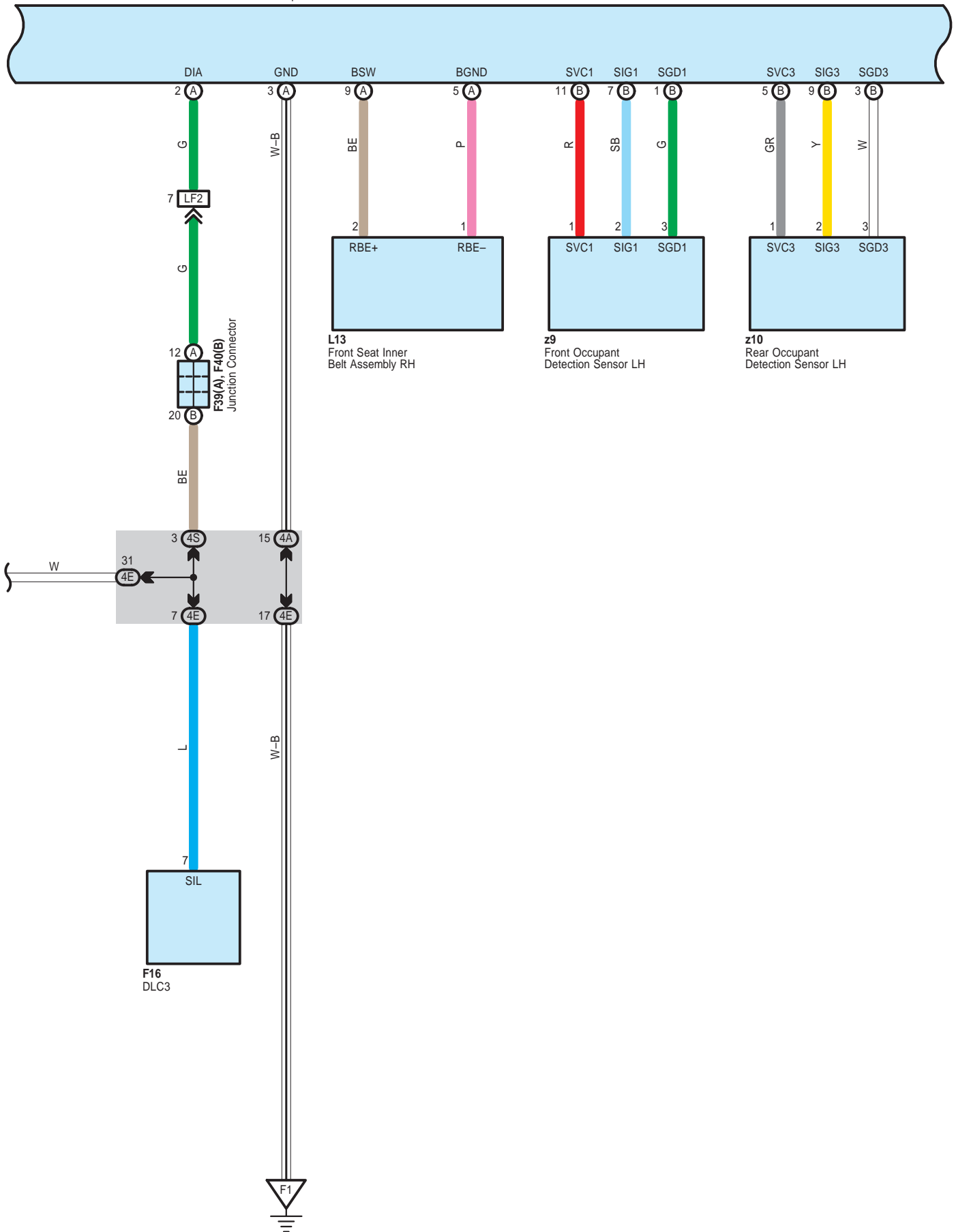

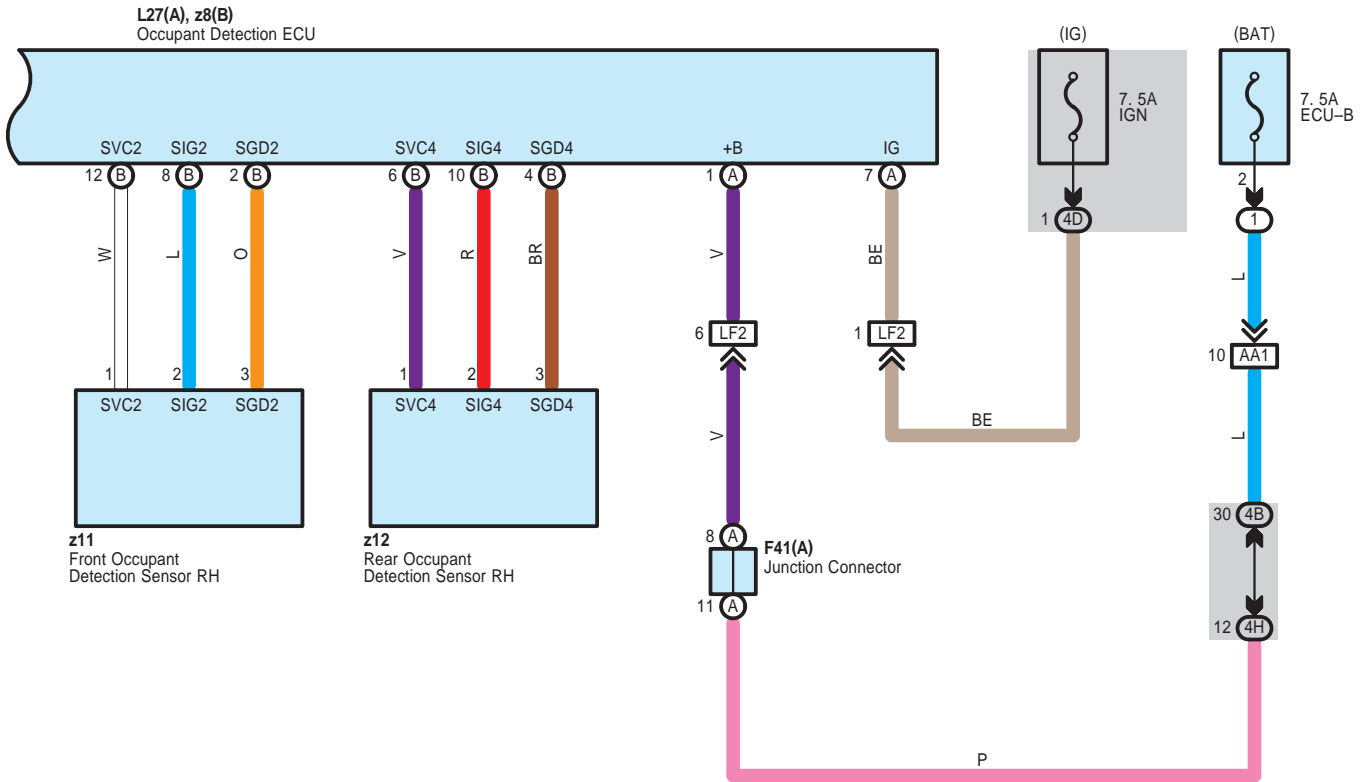

A 4
Yellow

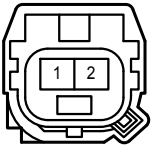

A 10
Yellow

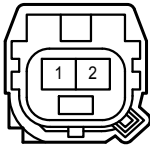

A 21
Black

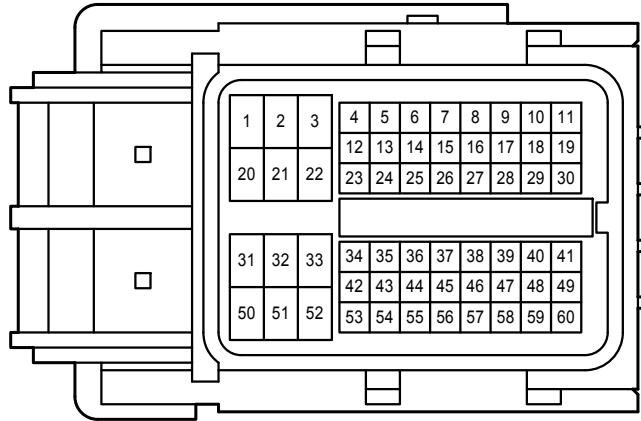

F 1
White

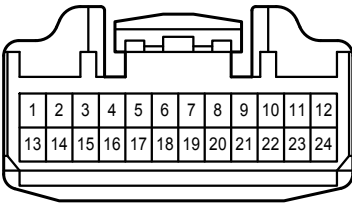

F 2
White

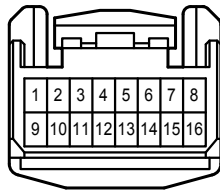

F 16
White

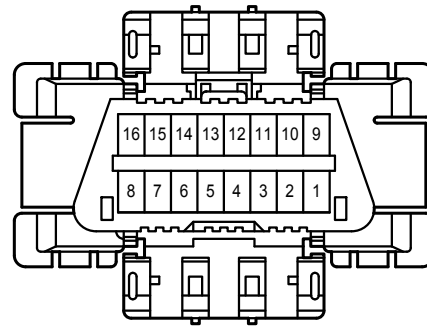

F 17
White



F 18
Yellow

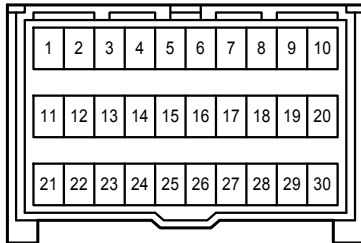

F 19
Yellow

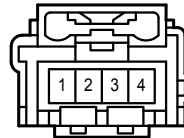

F 20
Yellow

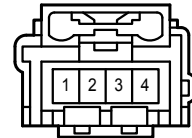

F 38
White

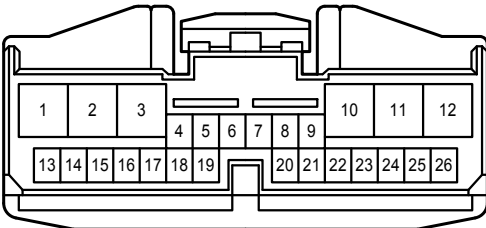

F 39
White

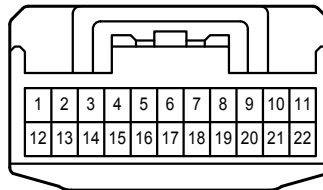

F 40
White

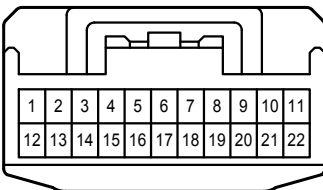

F 41
White

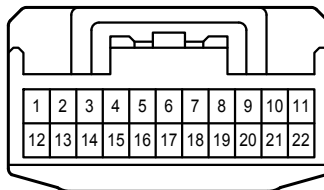

F 46
White

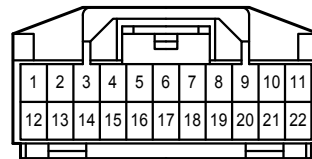

F 47
White

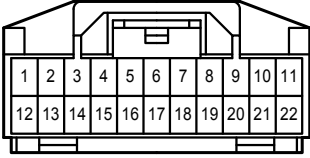

L 10
Yellow

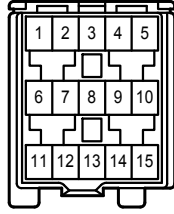

L 11
Yellow

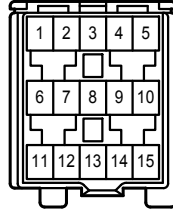

L 12
White



L 13
White

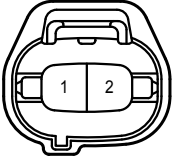

L 17
Yellow

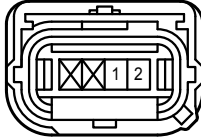

L 18
Yellow

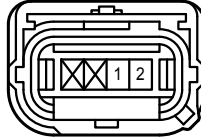

L 19
Yellow

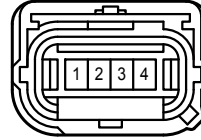

L 20
Yellow

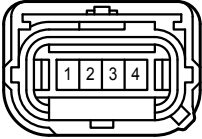

L 23
Yellow

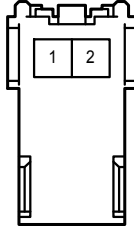

L 24
Yellow

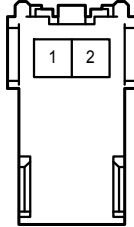

L 25
Black

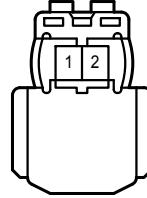

L 26
Black

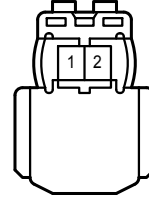

L 27
Black

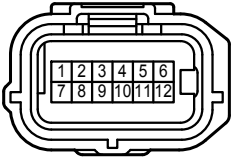

z 8
Gray

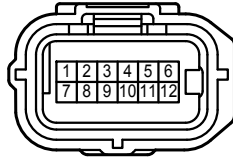

z 9
Black

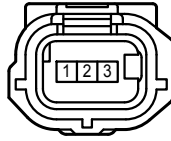

z 10
Black

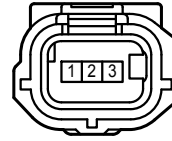

z 11
Black



z 12
Black



z 16
Orange

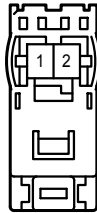

z 17
Black

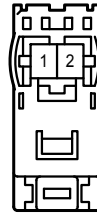

z 19
White

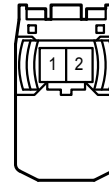

z 20
White

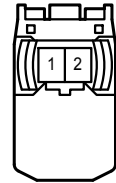

4A
White

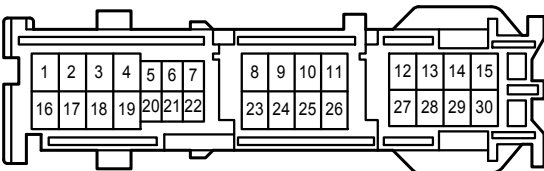

4B
White

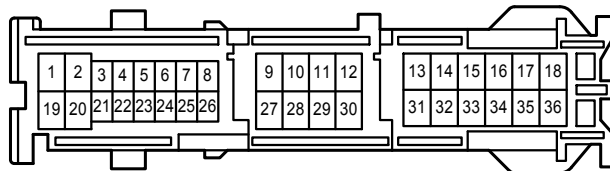

4D

White

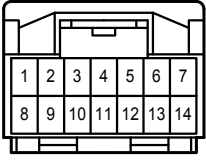

4E

White

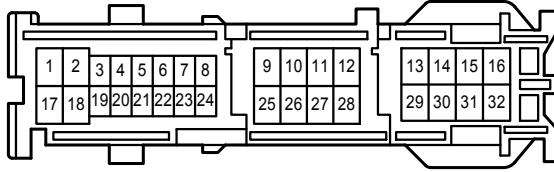

4H

White

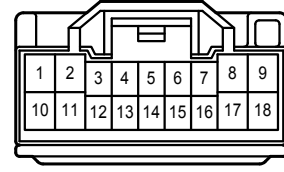

4M

White

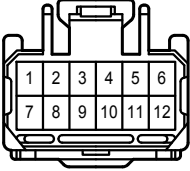

4S

White

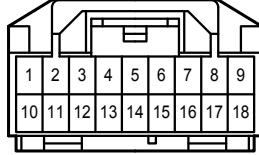

6A

White

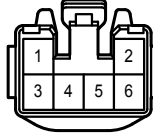

AA1

White

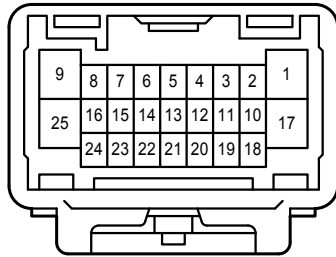
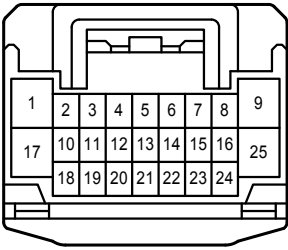

AF1

Yellow

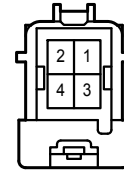
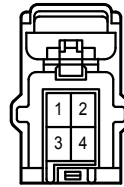

AF4

Gray

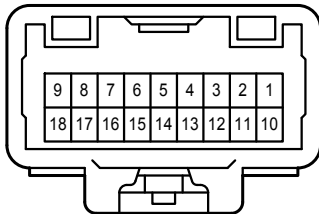
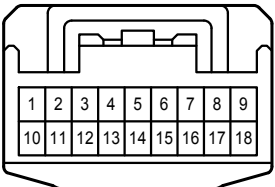

LF2

White

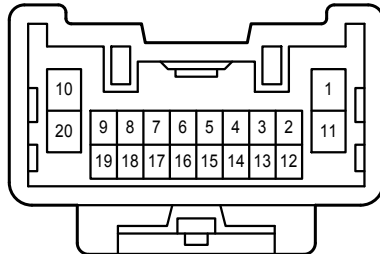
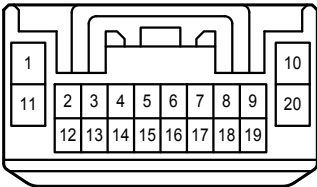

Lz1

Yellow

White



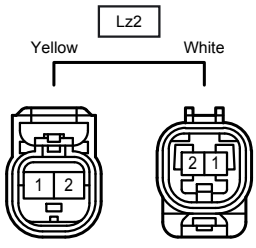

Starting

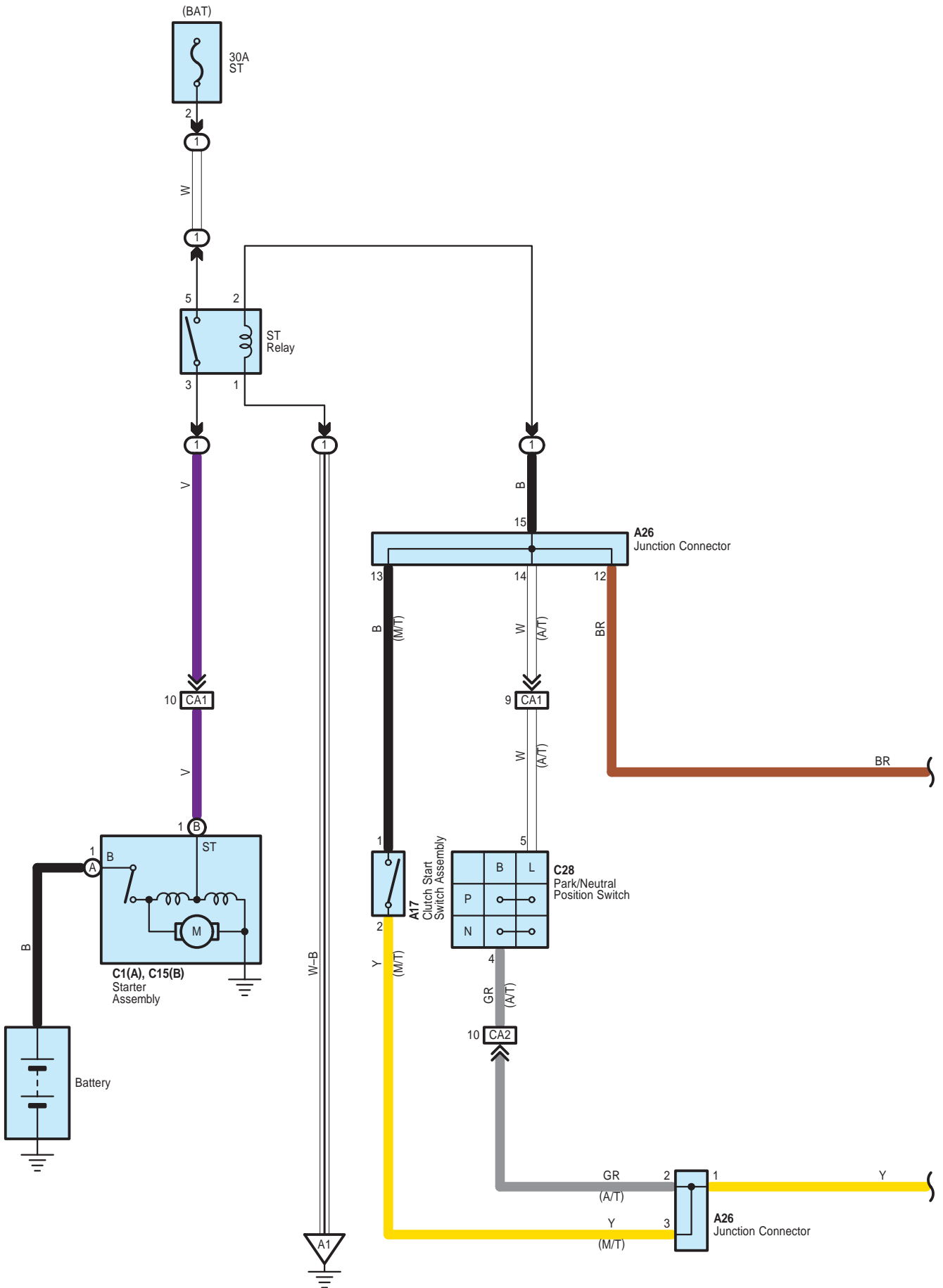

Starting

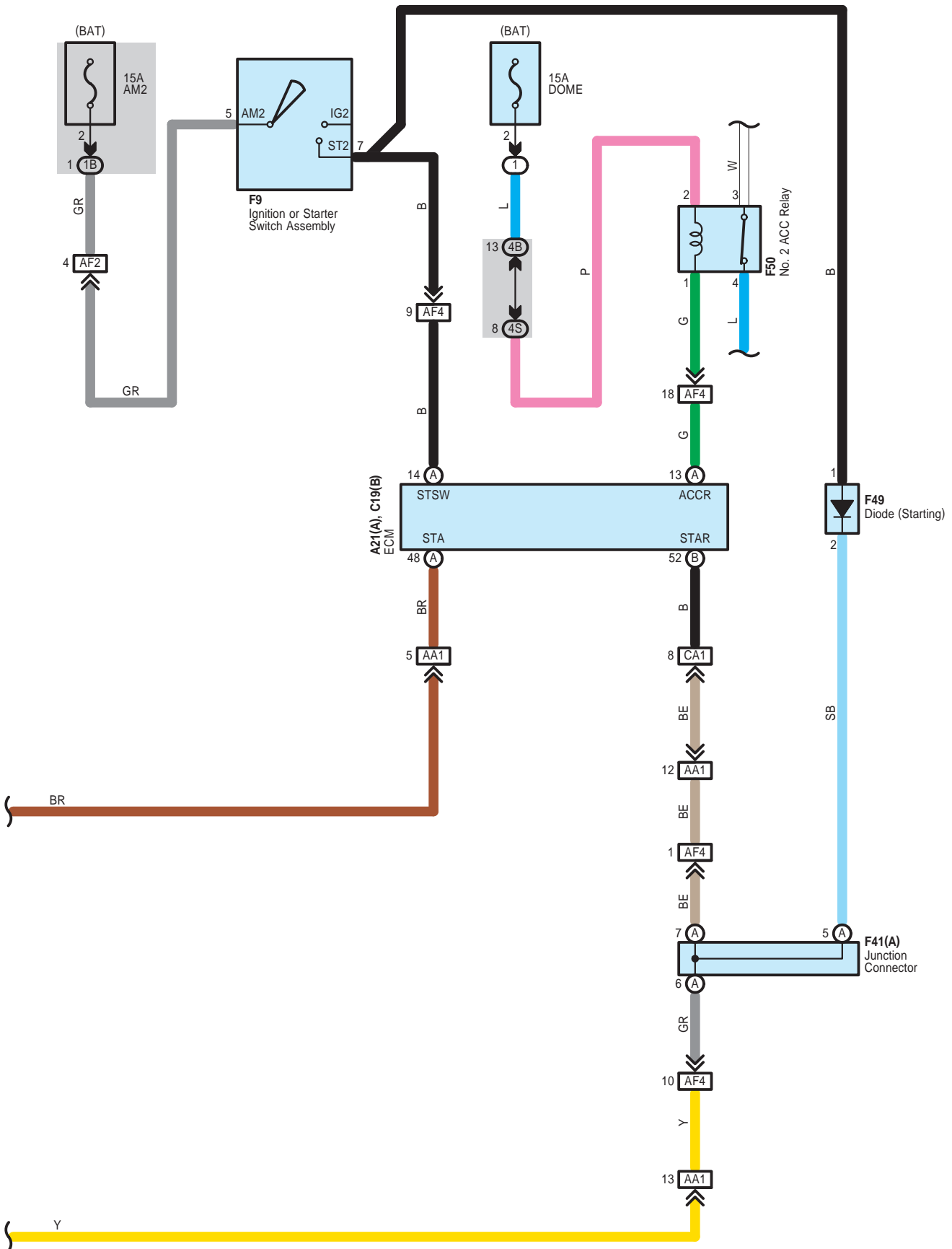

Starting

4S

White

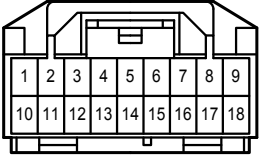

AA1

White

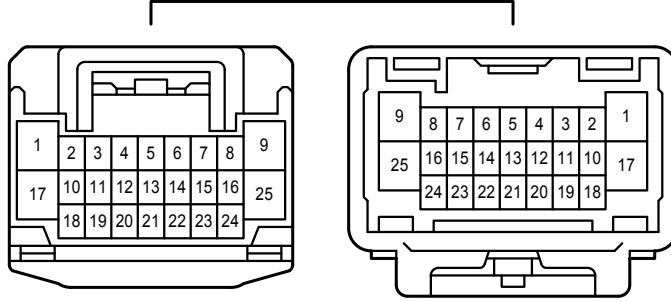

AF2

White

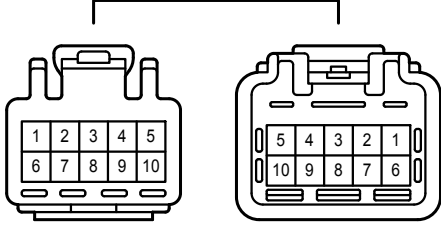

AF4

Gray

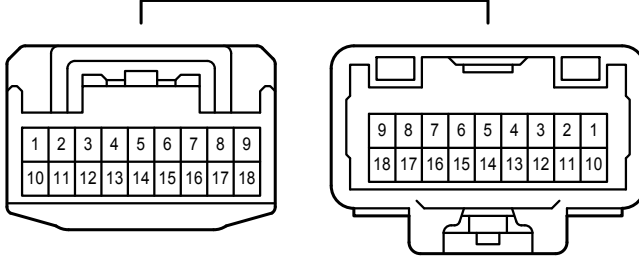

CA1

White

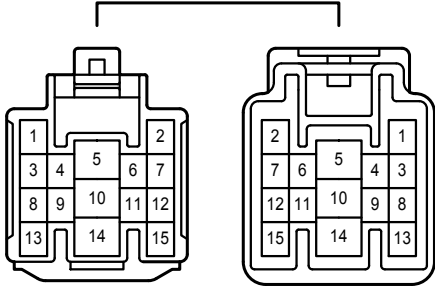

CA2

White

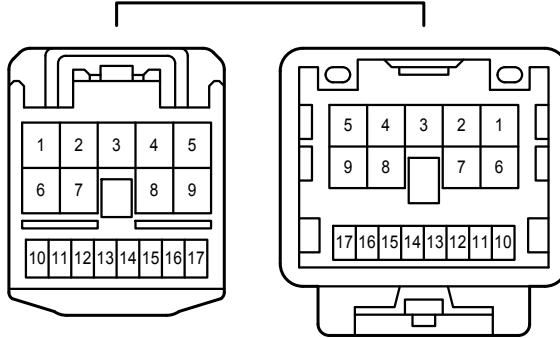

Stop Light

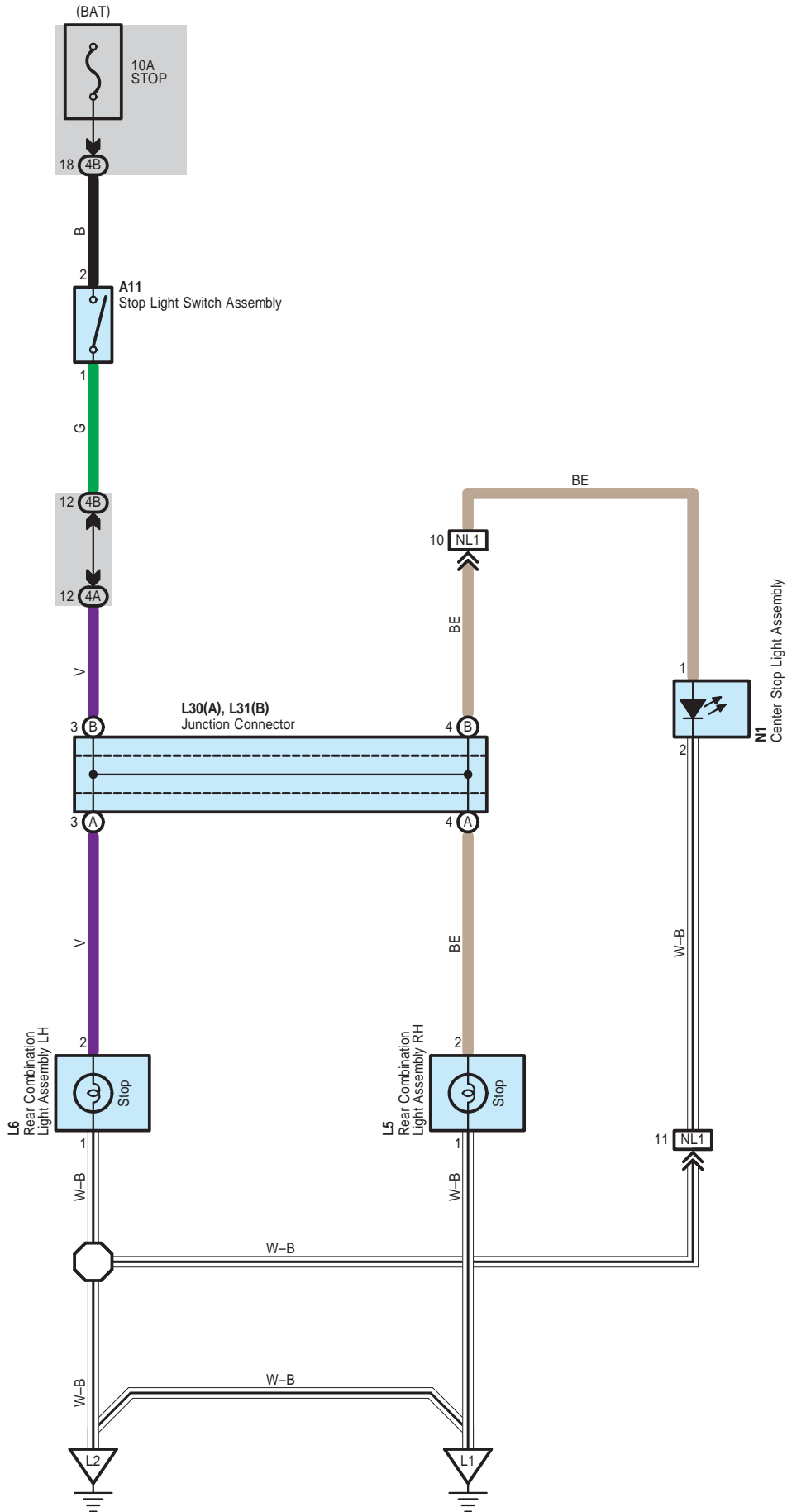

Stop Light

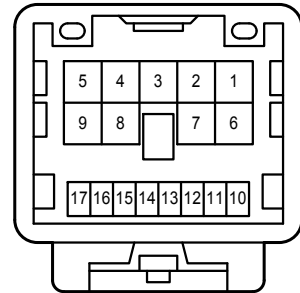
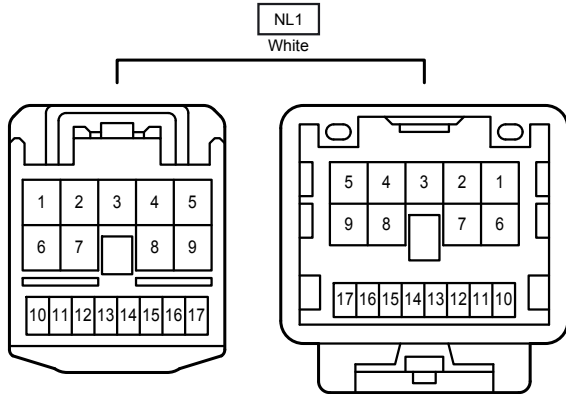
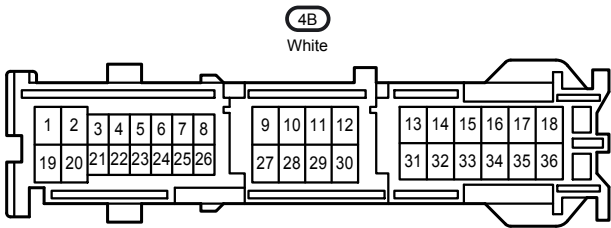
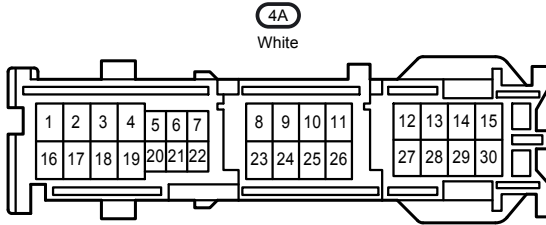
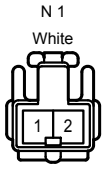
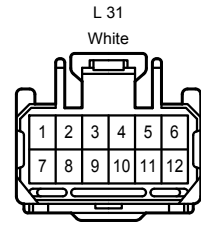
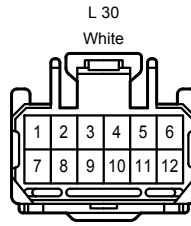
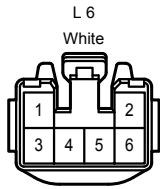
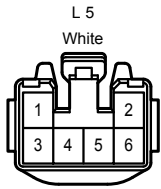
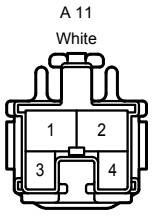

Tire Pressure Warning System

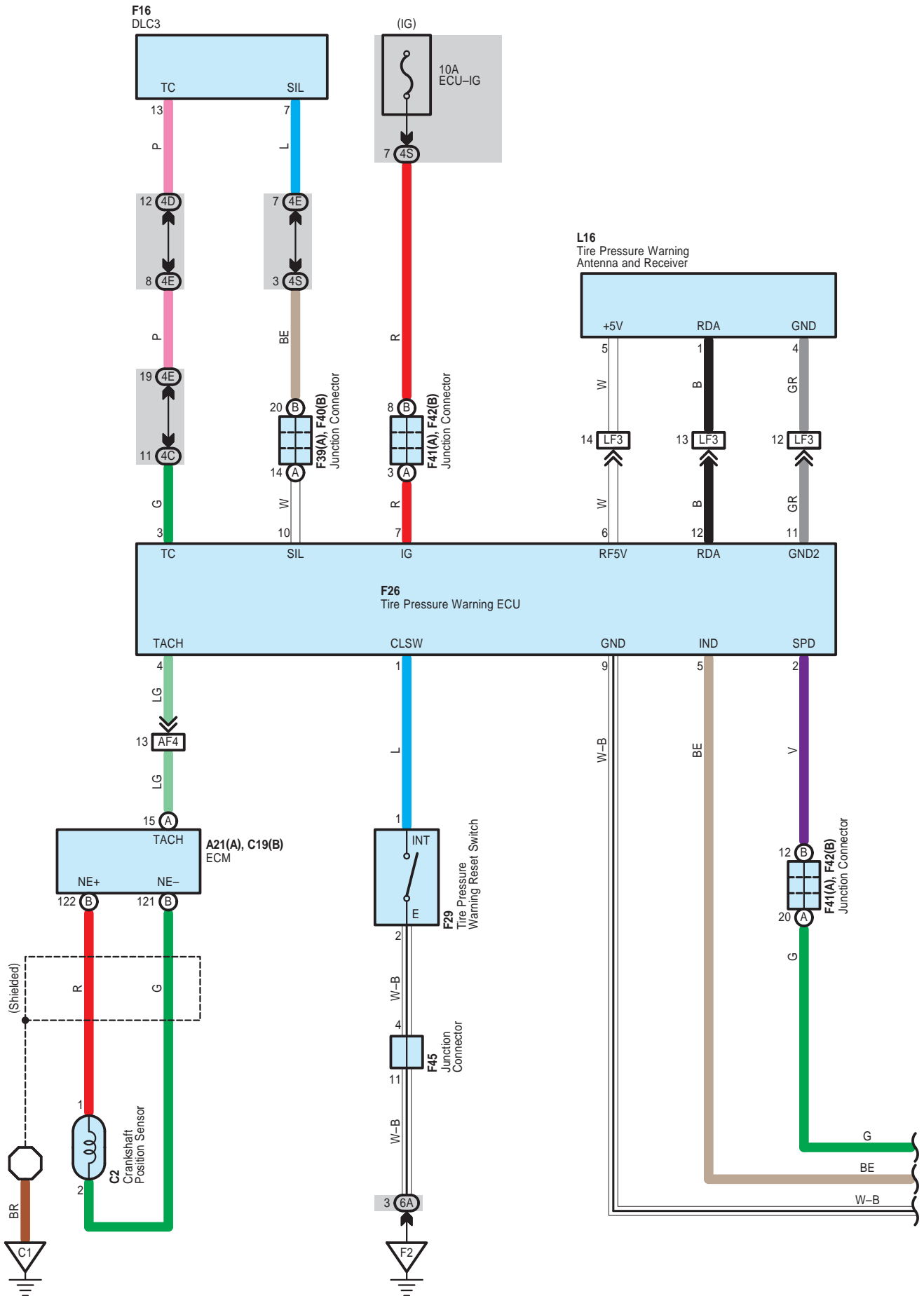

Tire Pressure Warning System

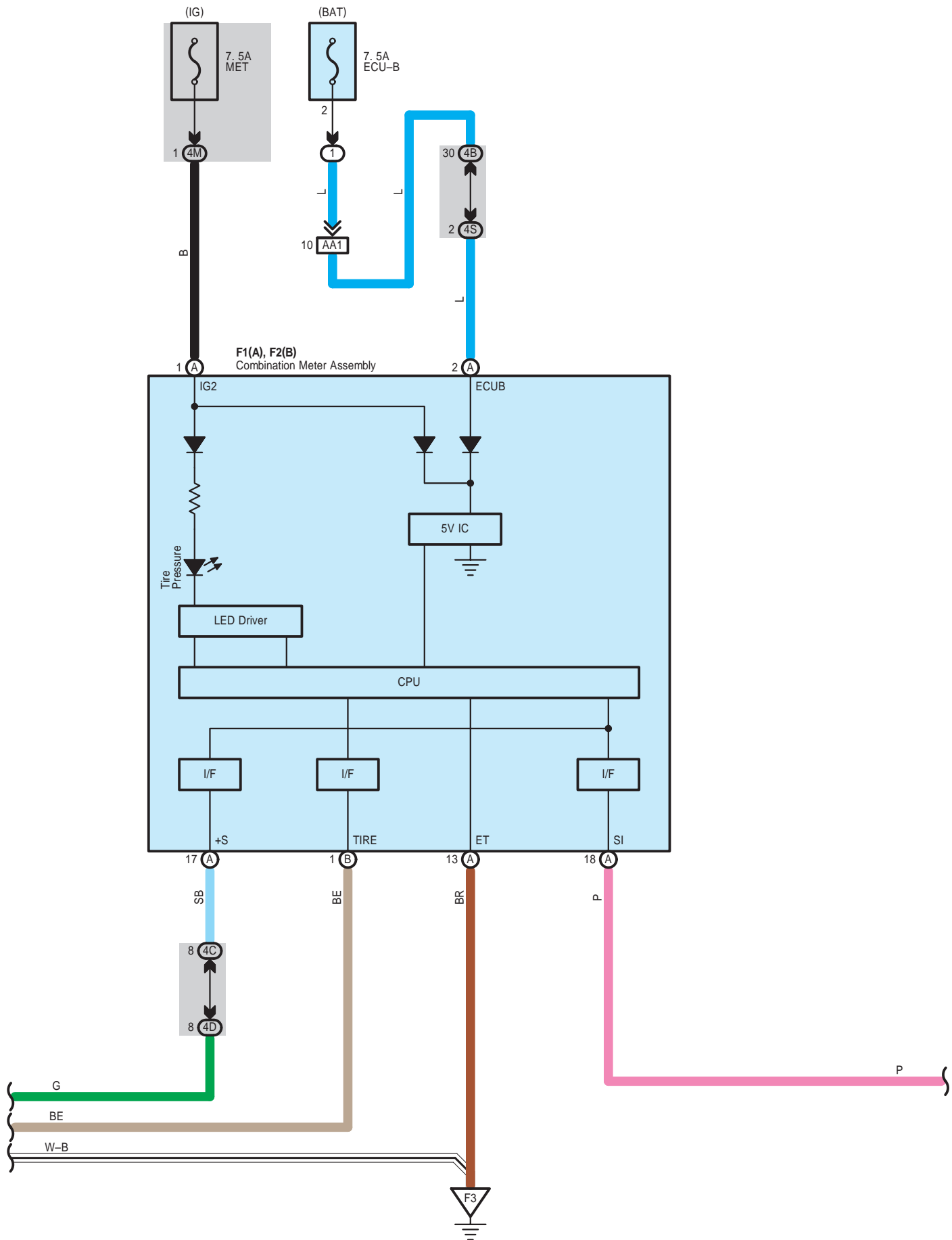

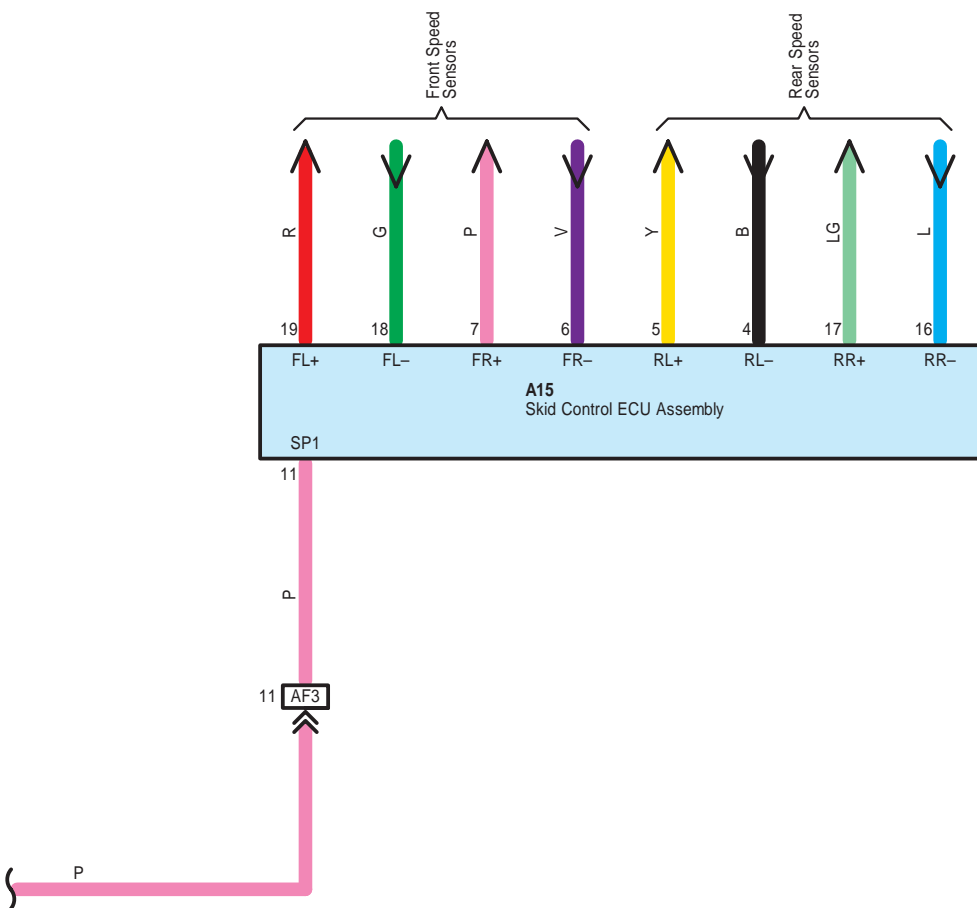

Tire Pressure Warning System

A 15
Black

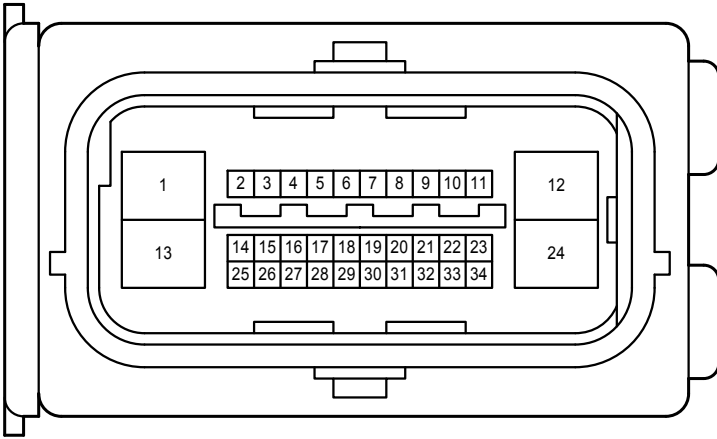

A 21
Black

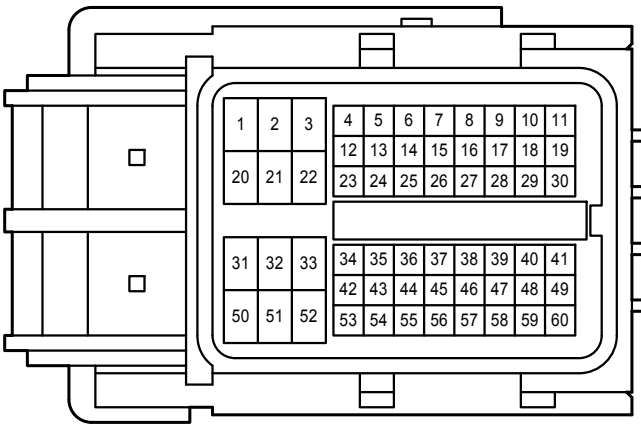

C 2
Black

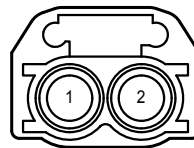

C 19
Black

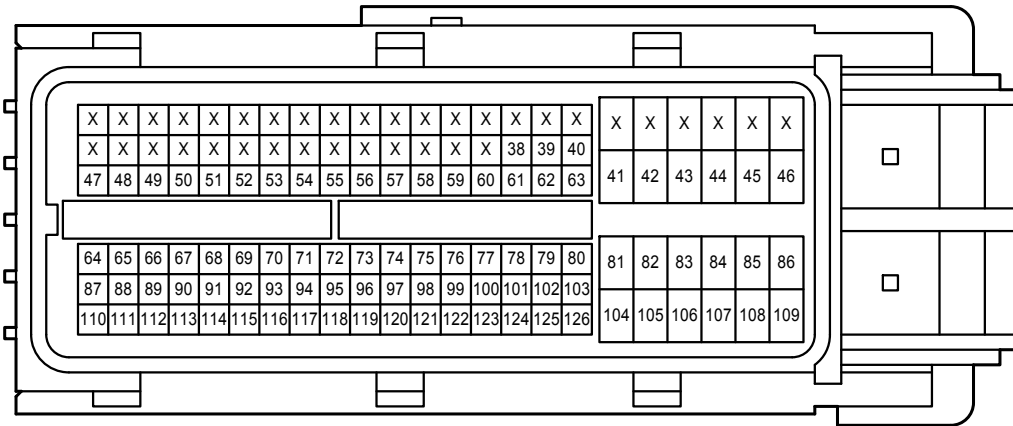

Tire Pressure Warning System

F 1
White

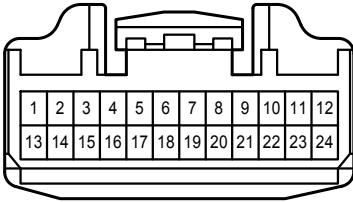

F 2
White

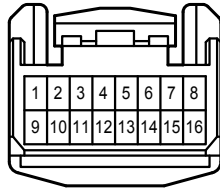

F 16
White

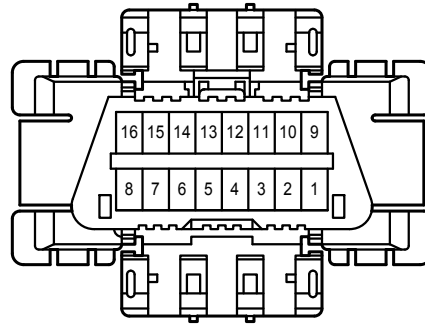

F 26
White



F 29
Black

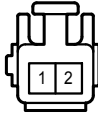

F 39
White

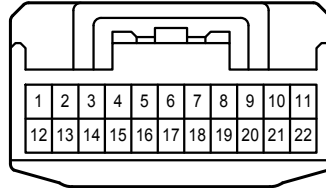

F 40
White

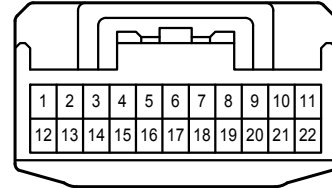

F 41
White

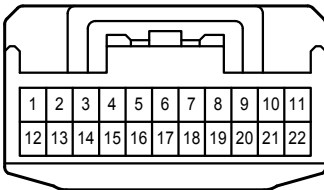

F 42
White

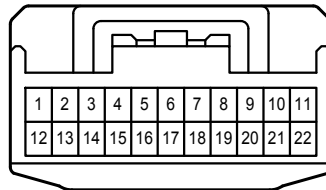

F 45
White

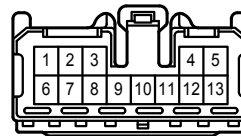

L 16
White

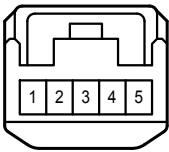

4B
White

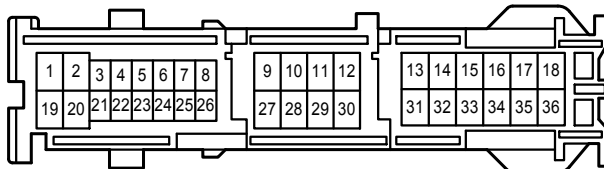

4C
White

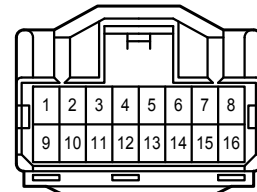

4D
White

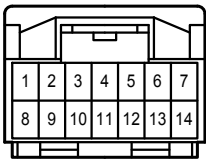

4E
White

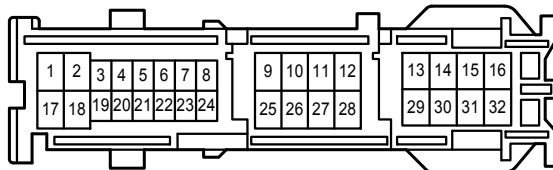

4M
White

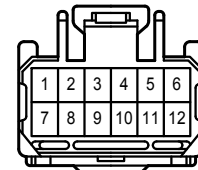

Tire Pressure Warning System

4S

White

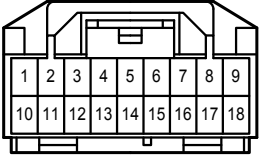

6A

White

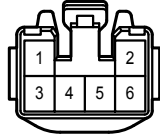

AA1

White

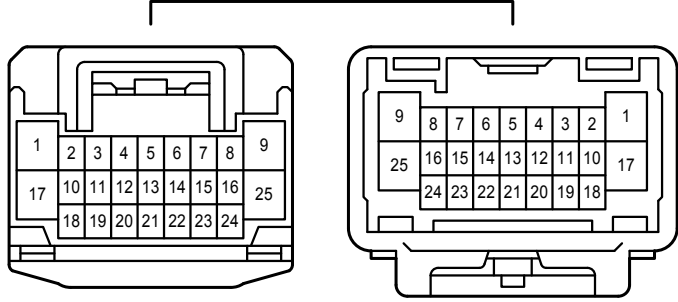

AF3

Black

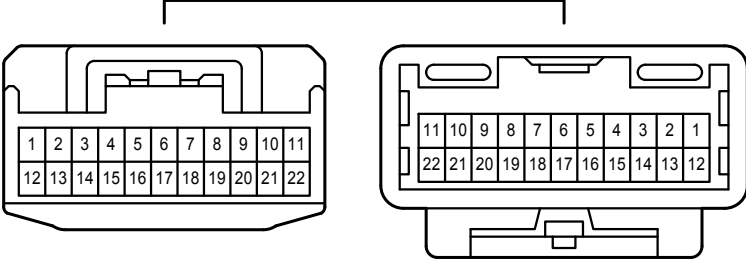

AF4

Gray

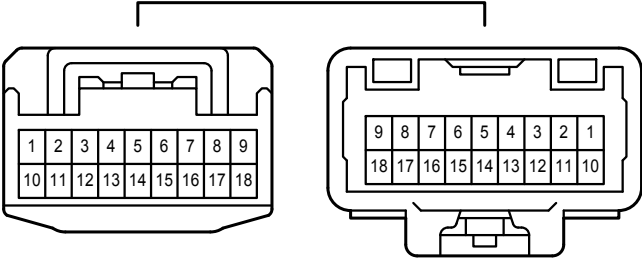

LF3

White

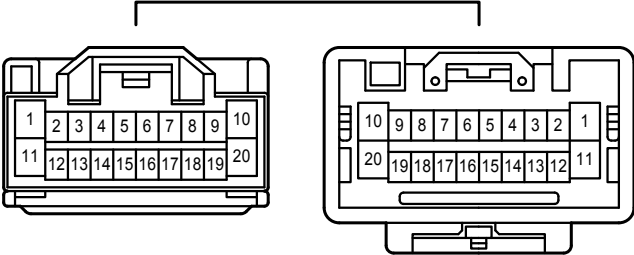

Turn Signal and Hazard Warning Light

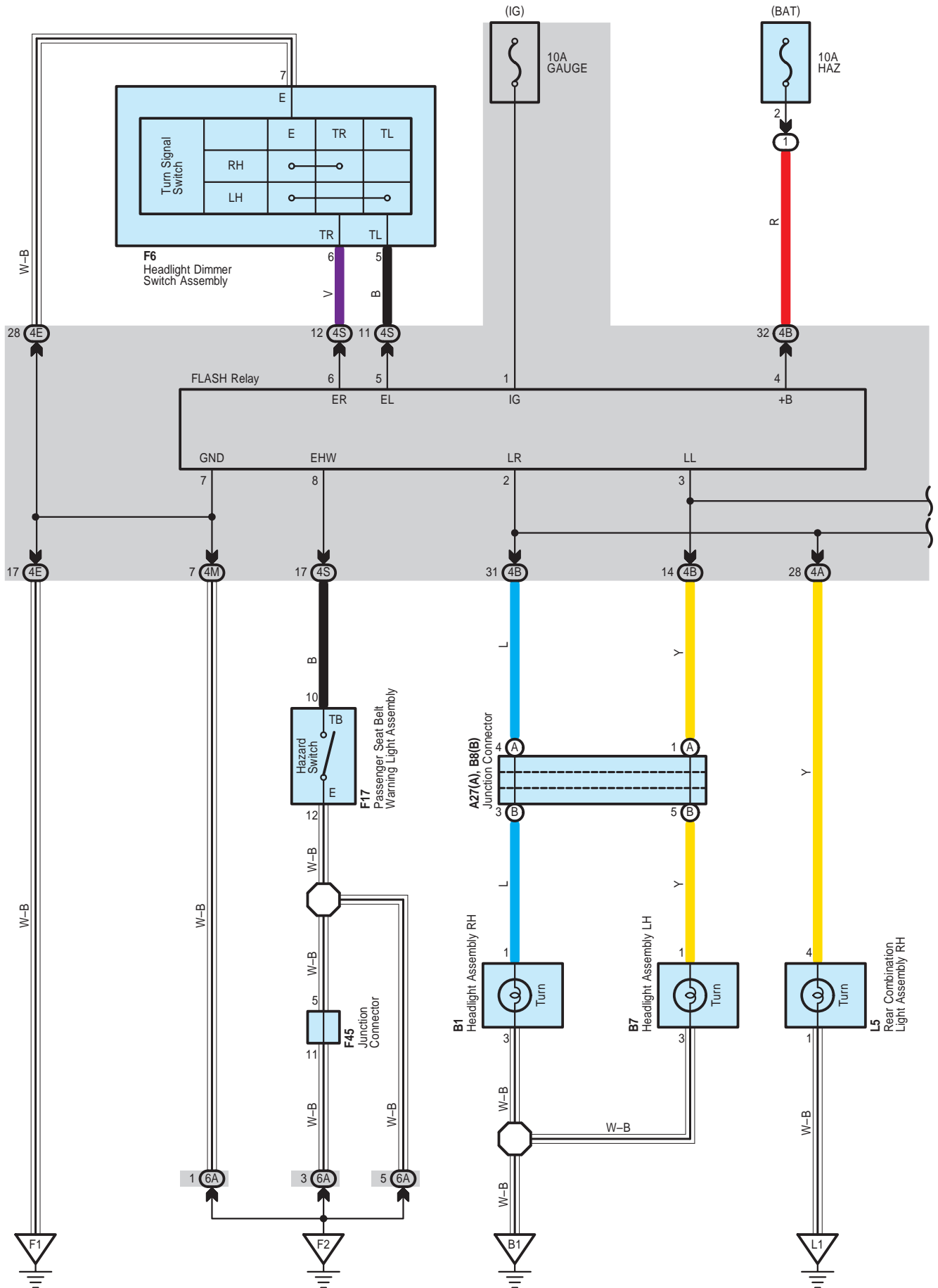

Turn Signal and Hazard Warning Light

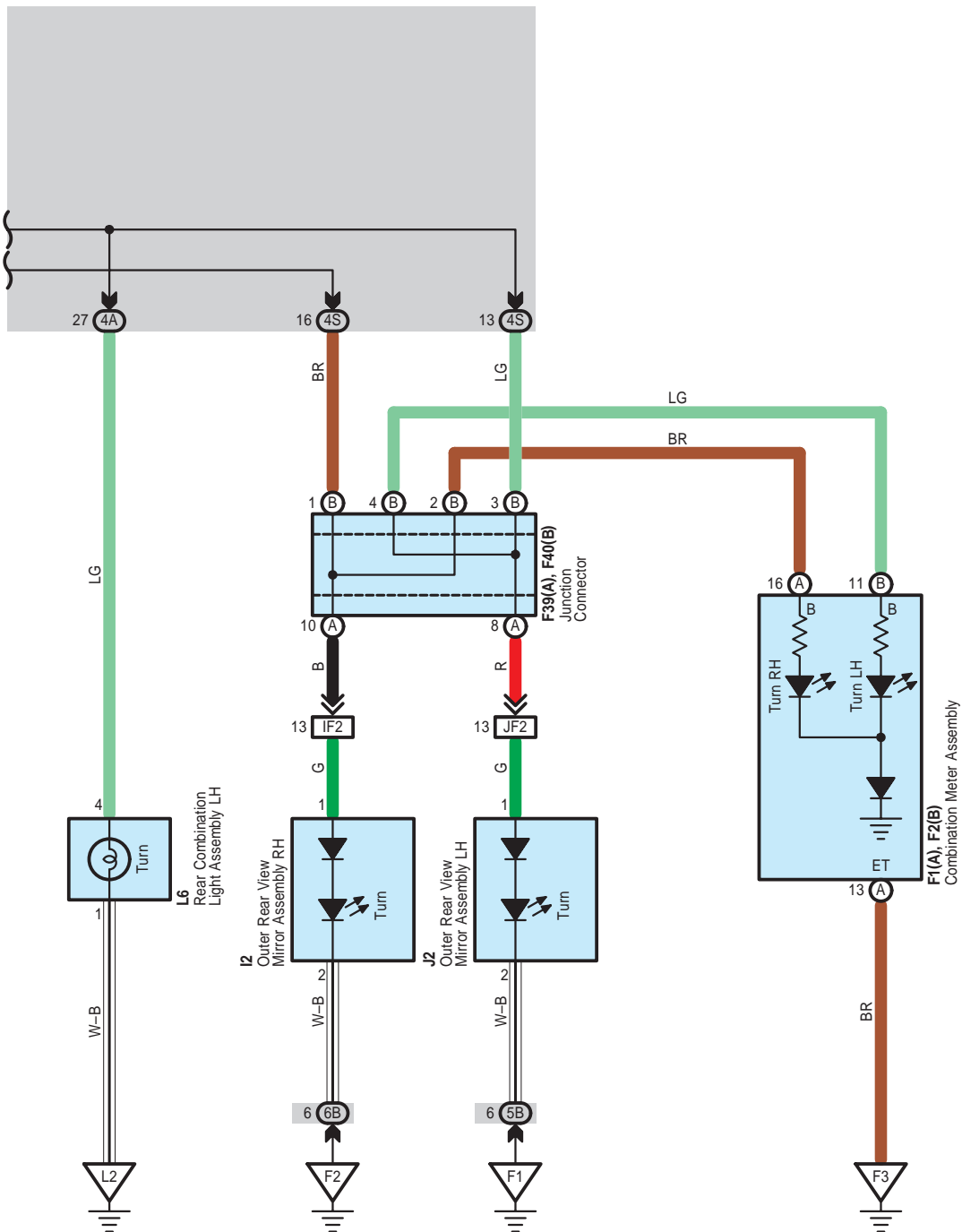

Turn Signal and Hazard Warning Light

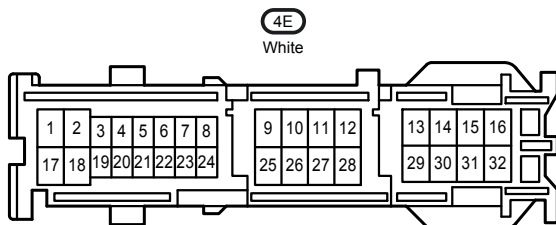
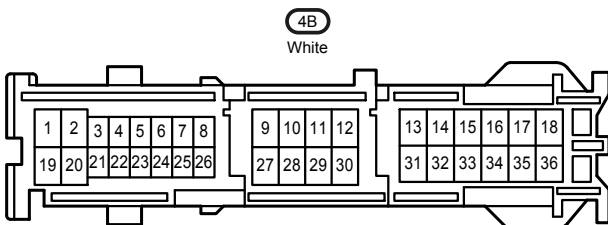
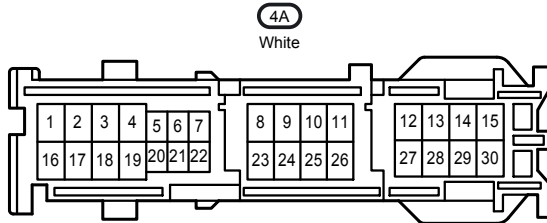
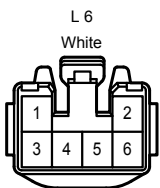
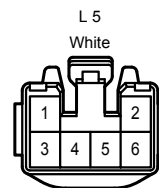
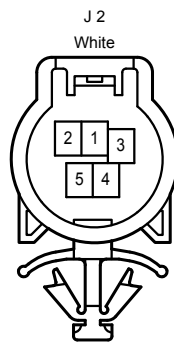
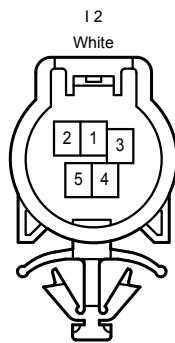
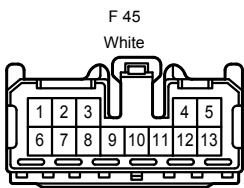
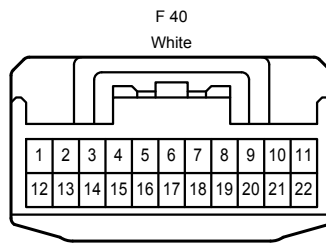
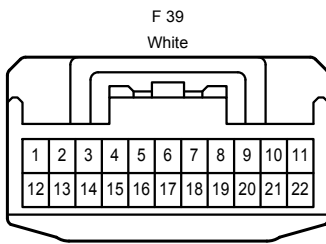
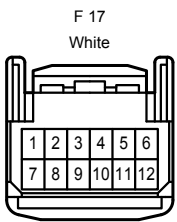
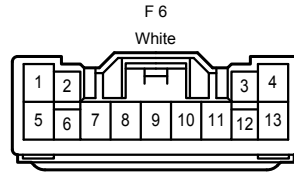
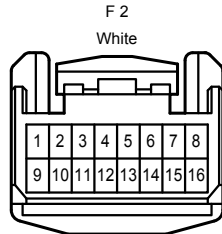
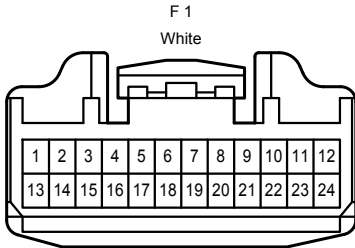
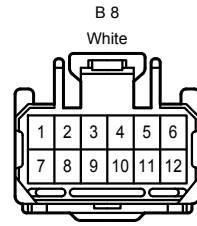
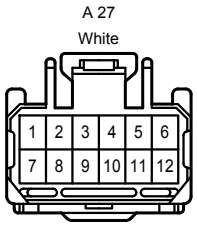

Turn Signal and Hazard Warning Light

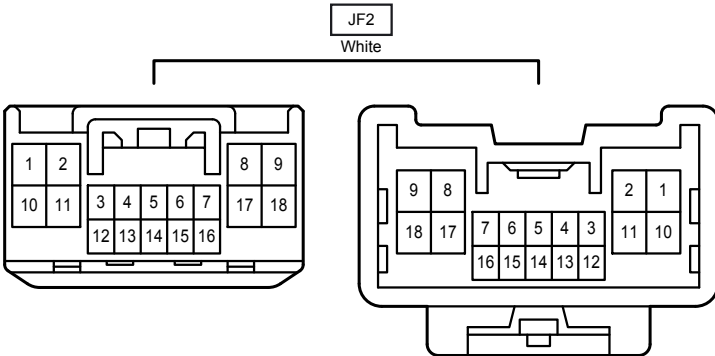
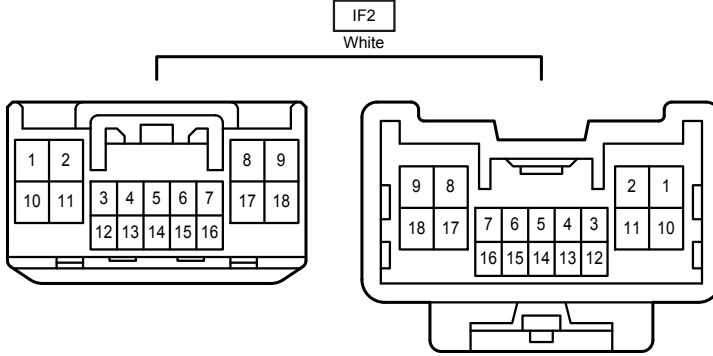
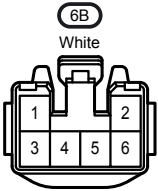
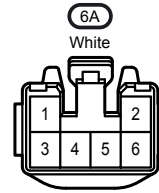
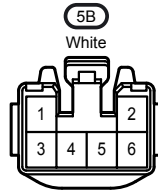
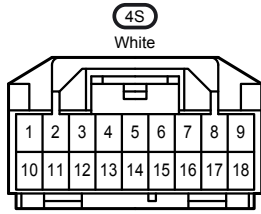
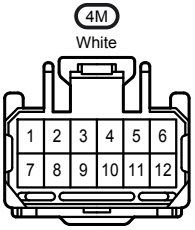

Wireless Door Lock Control

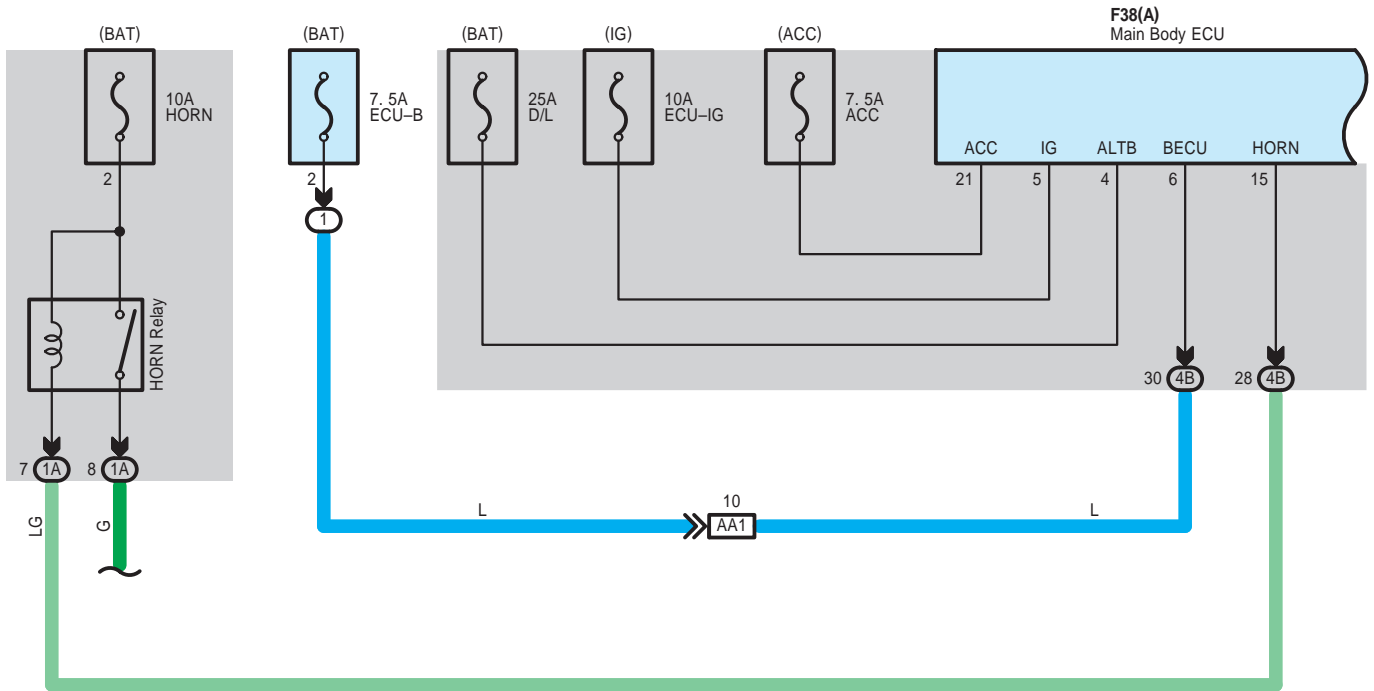

Wireless Door Lock Control

F38(A)
Main Body ECU

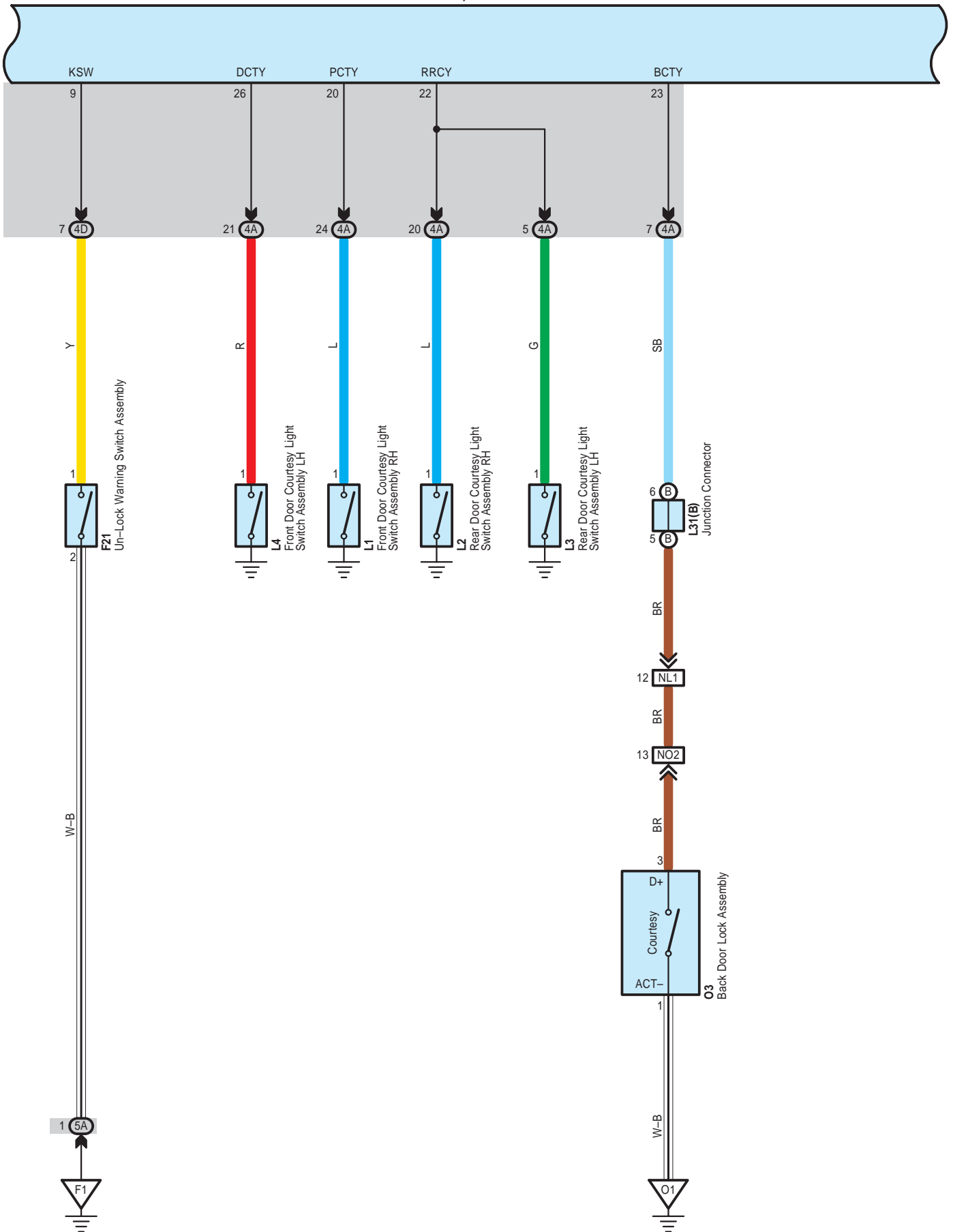

Wireless Door Lock Control

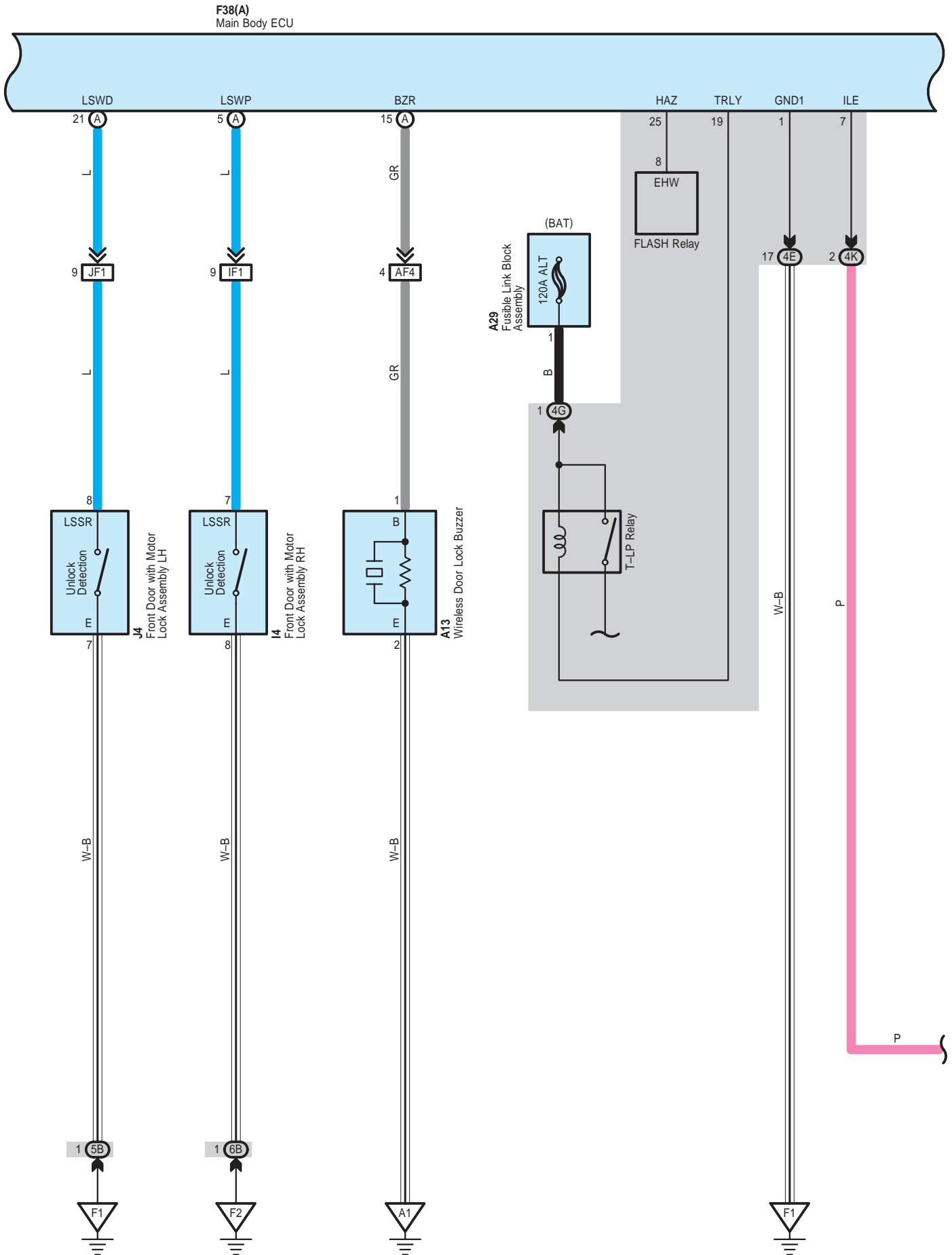

Wireless Door Lock Control

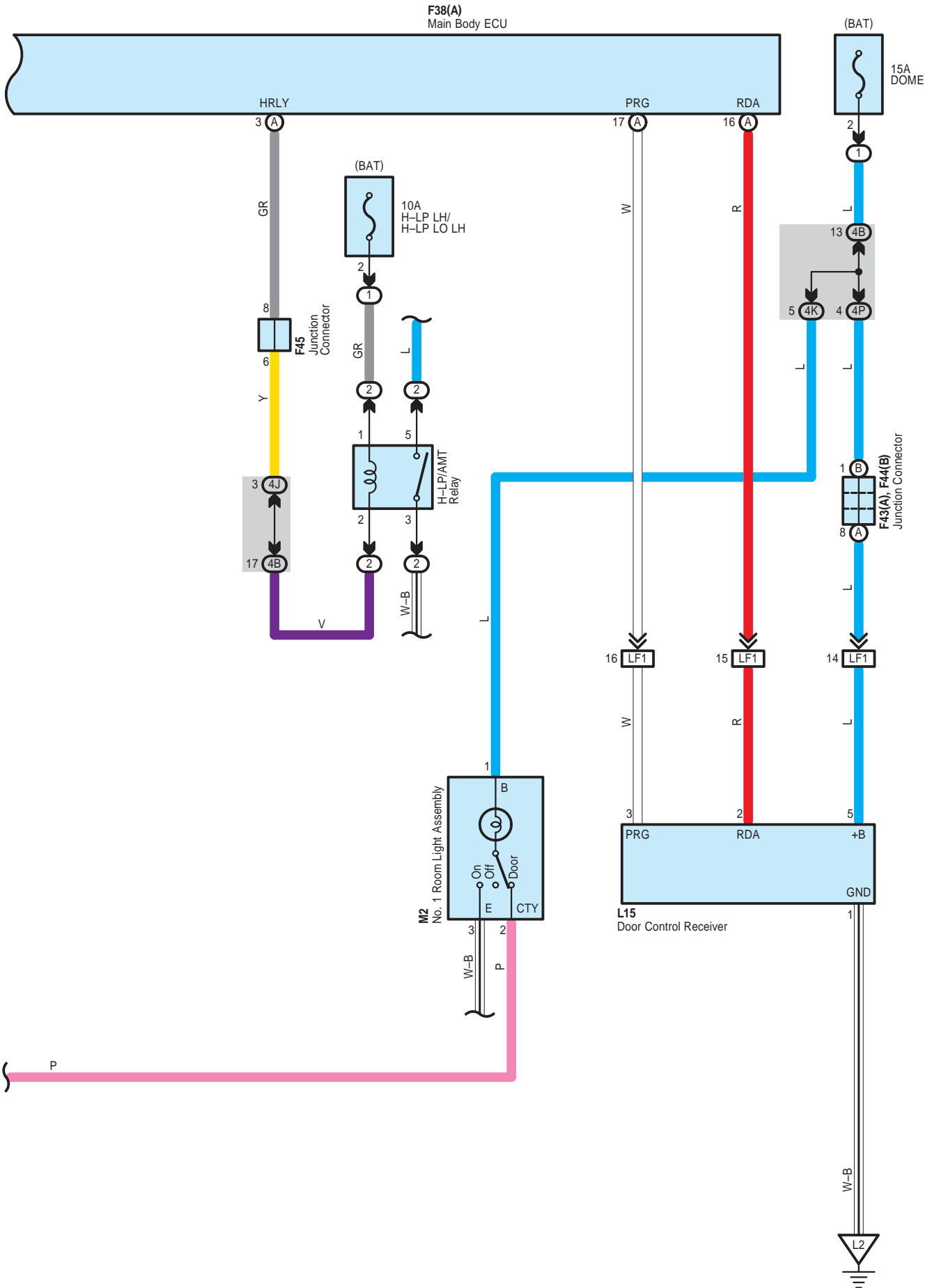

Wireless Door Lock Control

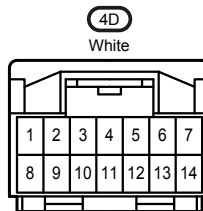
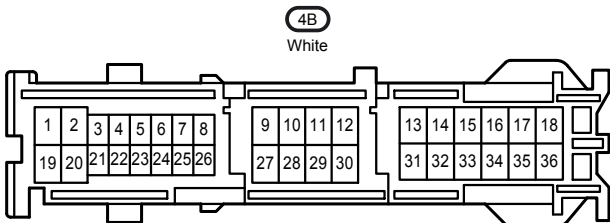
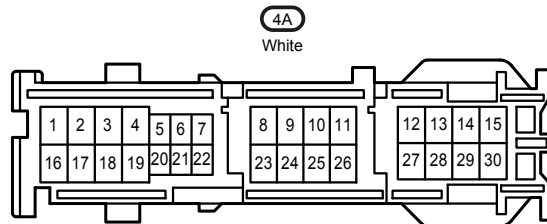
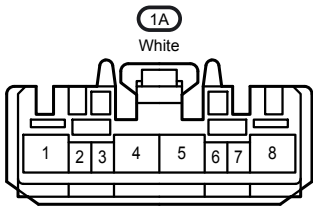
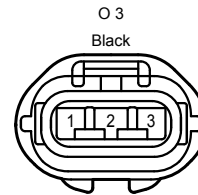
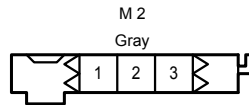
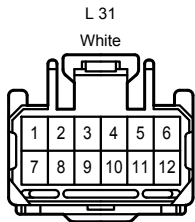
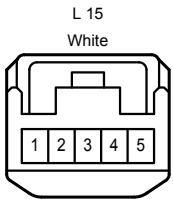
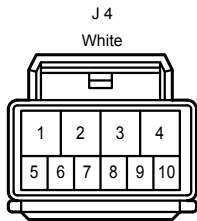
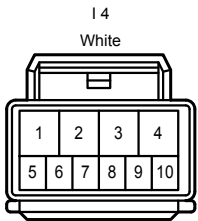
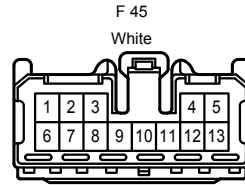
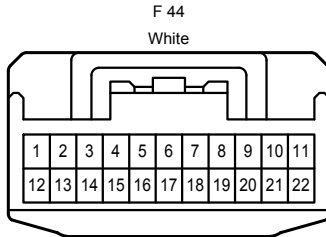
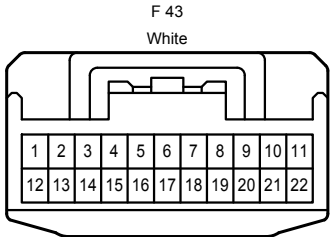
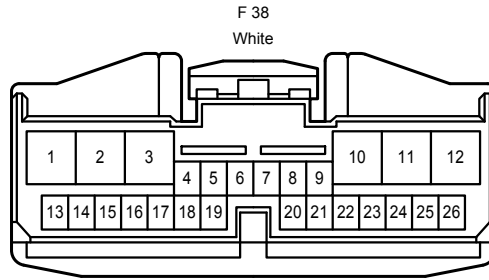
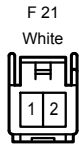
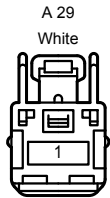
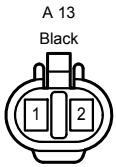

Wireless Door Lock Control

4E
White

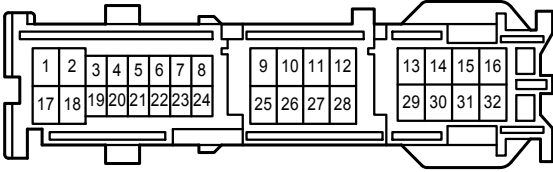

4G
White



4J
White

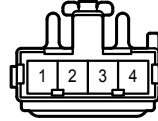

4K
White

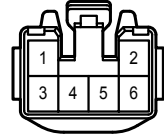

4P
White

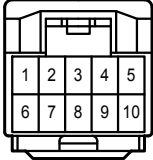

5A
White

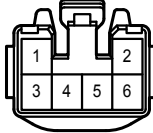

5B
White

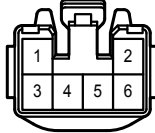

6B
White

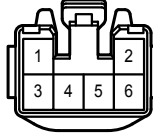

AA1
White

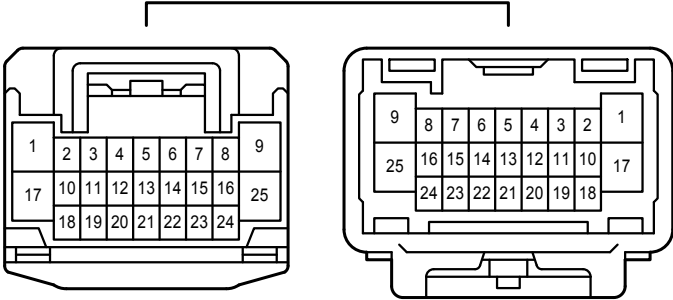

AF4
Gray

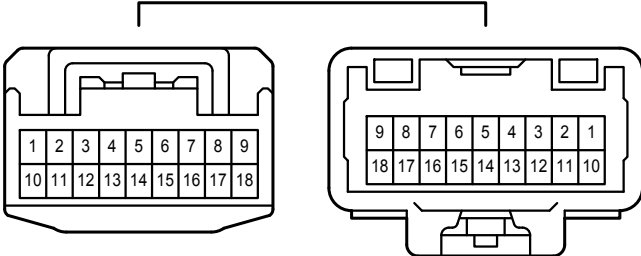

IF1
White

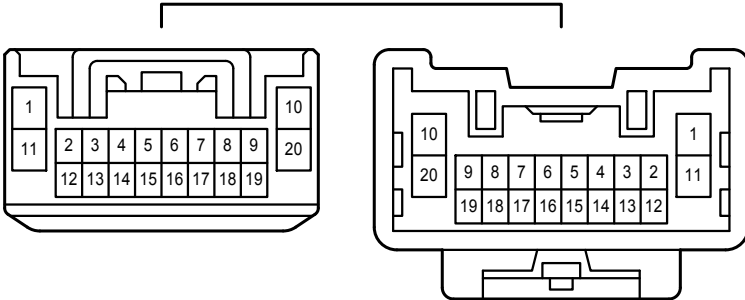

JF1
White

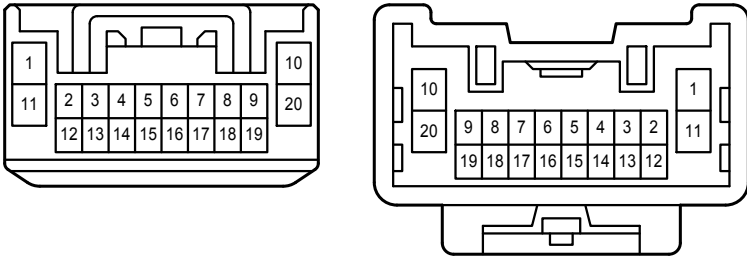

LF1
White

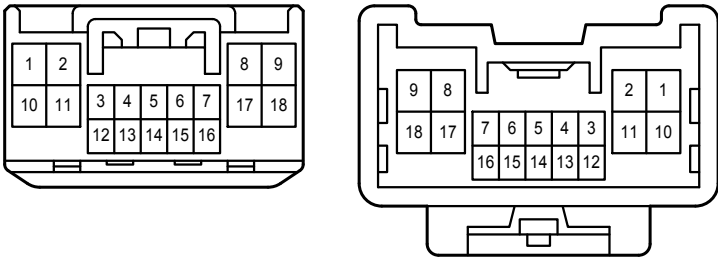

NL1
White

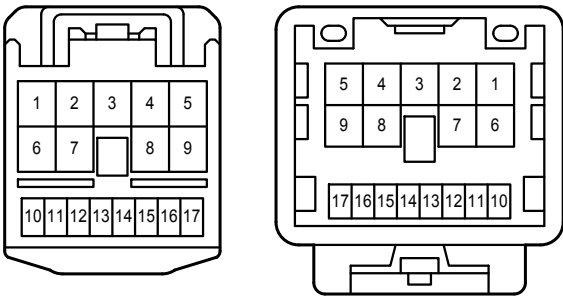

NO2
White

