

E151948E03

**Fig. 66: Identifying Combination Meter Components (2 Of 2)**  
 Courtesy of TOYOTA MOTOR SALES, U.S.A., INC.

**REMOVAL**

1. **DISCONNECT CABLE FROM NEGATIVE BATTERY TERMINAL**
2. **REMOVE INSTRUMENT CLUSTER FINISH PANEL**
  - a. Disengage the 8 claws and 5 clips and remove the cluster finish panel.

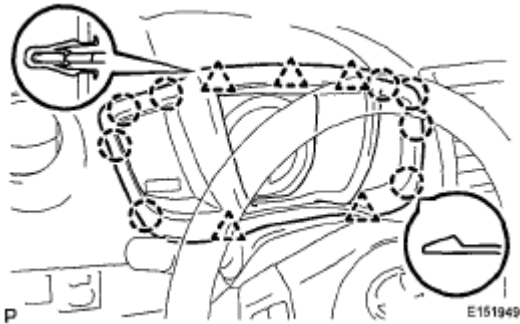

**Fig. 67: Identifying Cluster Finish Panel Claws And Clips**  
Courtesy of TOYOTA MOTOR SALES, U.S.A., INC.

**3. REMOVE COMBINATION METER ASSEMBLY**

- a. Disconnect the 2 connectors and remove the 2 screws.
- b. Disengage the 2 clips and remove the combination meter assembly.

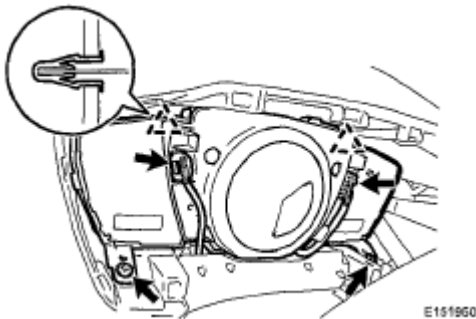
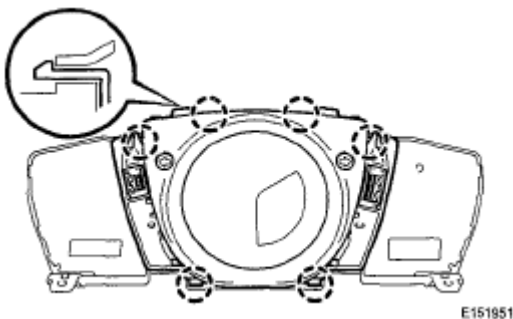

**Fig. 68: Identifying Combination Meter Assembly Clips**  
Courtesy of TOYOTA MOTOR SALES, U.S.A., INC.

**DISASSEMBLY**

**1. REMOVE NO. 2 COMBINATION METER COVER**

- a. Disengage the 6 claws and remove the No. 2 combination meter cover.

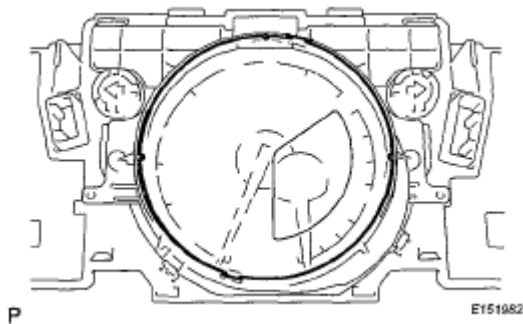

**Fig. 69: Identifying No. 2 Combination Meter Cover Claws**

Courtesy of TOYOTA MOTOR SALES, U.S.A., INC.

**2. REMOVE COMBINATION METER GLASS**

- a. Remove the combination meter glass.



**Fig. 70: Identifying Combination Meter Glass**  
Courtesy of TOYOTA MOTOR SALES, U.S.A., INC.

**3. REMOVE NO. 1 COMBINATION METER COVER**

- a. Disengage the 4 claws and remove the No. 1 combination meter cover.

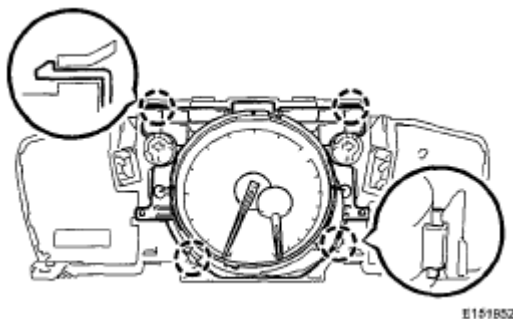

**Fig. 71: Identifying No. 1 Combination Meter Cover Claws**  
Courtesy of TOYOTA MOTOR SALES, U.S.A., INC.

**4. REMOVE NO. 1 METER LENS**

- a. Disengage the 3 guides and remove the No. 1 meter lens.

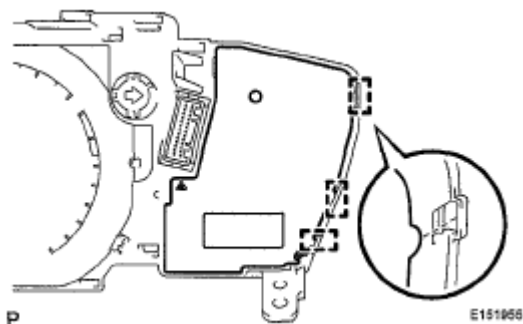
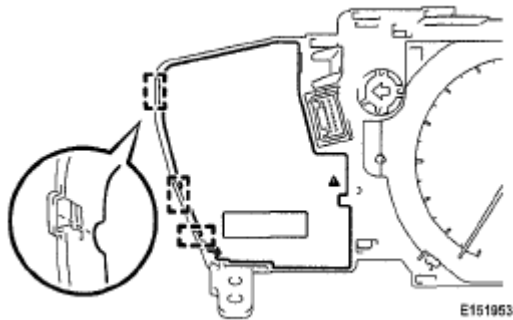

**Fig. 72: Identifying No. 1 Meter Lens Guides**

Courtesy of TOYOTA MOTOR SALES, U.S.A., INC.

**5. REMOVE NO. 2 METER LENS**

- a. Disengage the 3 guides and remove the No. 2 meter lens.

**Fig. 73: Identifying No. 2 Meter Lens Guides**

Courtesy of TOYOTA MOTOR SALES, U.S.A., INC.

**6. REMOVE NO. 3 METER LENS**

- a. Remove the 2 No. 3 meter lenses.

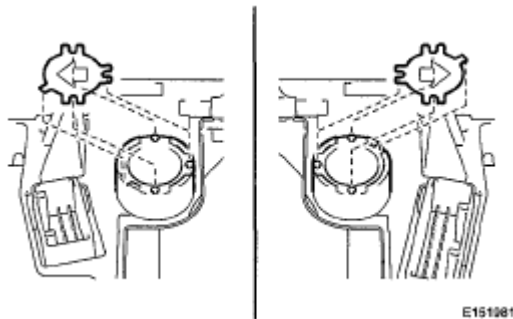
**Fig. 74: Removing No. 3 Meter Lenses**

Courtesy of TOYOTA MOTOR SALES, U.S.A., INC.

**7. REMOVE CLIP**

- a. Remove the 2 clips.

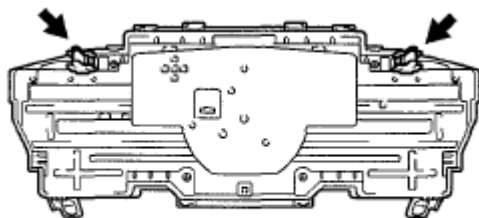
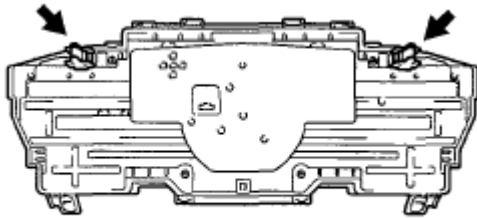

**Fig. 75: Locating Clips**

Courtesy of TOYOTA MOTOR SALES, U.S.A., INC.

**REASSEMBLY****1. INSTALL CLIP**

- a. Install the 2 clips.



P

E151954E02

**Fig. 76: Locating Clips**

Courtesy of TOYOTA MOTOR SALES, U.S.A., INC.

**2. INSTALL NO. 3 METER LENS**

- a. Align the protrusion of the combination meter with the cutout of the 2 No. 3 meter lenses and install the 2 No. 3 meter lenses.

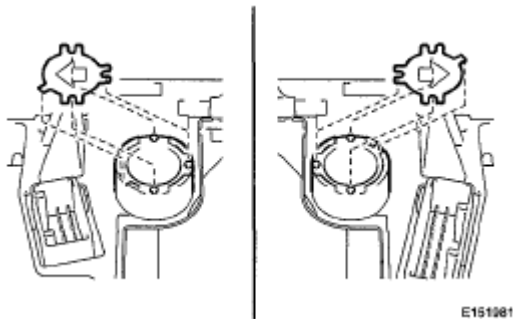

E151981

**Fig. 77: Installing No. 3 Meter Lens**

Courtesy of TOYOTA MOTOR SALES, U.S.A., INC.

**3. INSTALL NO. 2 METER LENS**

- a. Engage the 3 guides and install the No. 2 meter lens.

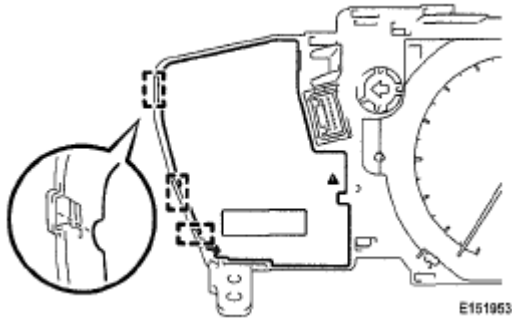

**Fig. 78: Identifying No. 2 Meter Lens Guides**  
Courtesy of TOYOTA MOTOR SALES, U.S.A., INC.

**4. INSTALL NO. 1 METER LENS**

- a. Engage the 3 guides and install the No. 1 meter lens.

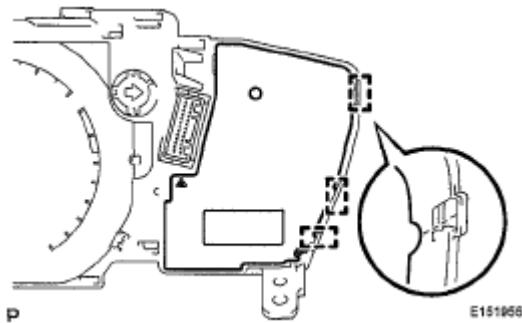

**Fig. 79: Identifying No. 1 Meter Lens Guides**  
Courtesy of TOYOTA MOTOR SALES, U.S.A., INC.

**5. INSTALL NO. 1 COMBINATION METER COVER**

- a. Engage the 4 claws and install the No. 1 combination meter cover.

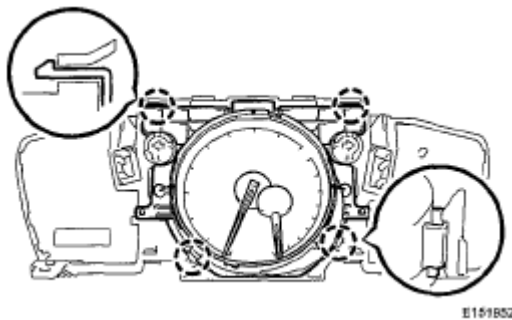

**Fig. 80: Identifying No. 1 Combination Meter Cover Claws**  
Courtesy of TOYOTA MOTOR SALES, U.S.A., INC.

**6. INSTALL COMBINATION METER GLASS**

**Fig. 83: Locating Combination Meter Clips**

Courtesy of TOYOTA MOTOR SALES, U.S.A., INC.

- b. Install the 2 screws and connect the 2 connectors.
2. **INSTALL INSTRUMENT CLUSTER FINISH PANEL**
- a. Engage the 8 claws and the 5 clips and install the cluster finish panel.

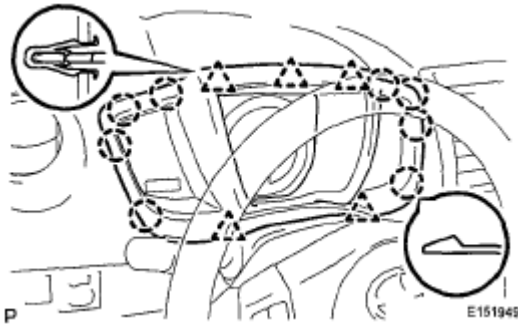

**Fig. 84: Identifying Cluster Finish Panel Claws And Clips**

Courtesy of TOYOTA MOTOR SALES, U.S.A., INC.

3. **CONNECT CABLE TO NEGATIVE BATTERY TERMINAL**

Torque: 5.4 N\*m (55 kgf\*cm, 48 in.\*lbf)

## LIGHT CONTROL RHEOSTAT

### COMPONENTS

- a. Align the protrusion of the No. 2 combination meter cover with the cutout of the combination meter glass and install the combination meter glass.

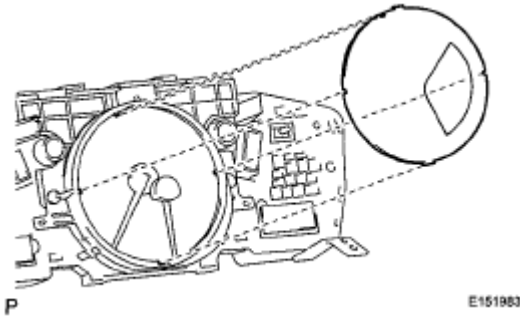

**Fig. 81: Installing Combination Meter Glass**  
Courtesy of TOYOTA MOTOR SALES, U.S.A., INC.

## 7. INSTALL NO. 2 COMBINATION METER COVER

- a. Engage the 6 claws and install the No. 2 combination meter cover.

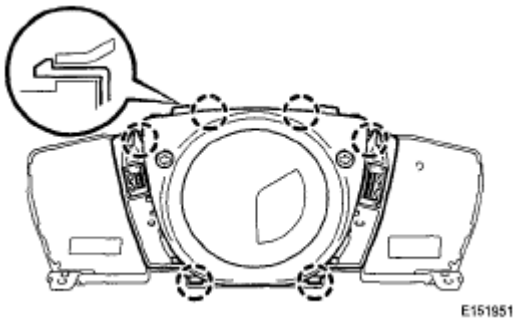

**Fig. 82: Identifying No. 2 Combination Meter Cover Claws**  
Courtesy of TOYOTA MOTOR SALES, U.S.A., INC.

## INSTALLATION

### 1. INSTALL COMBINATION METER ASSEMBLY

- a. Engage the 2 clips and install the combination meter.

